

COM Express Type 6 Ultra-Lite Carrier Users Guide

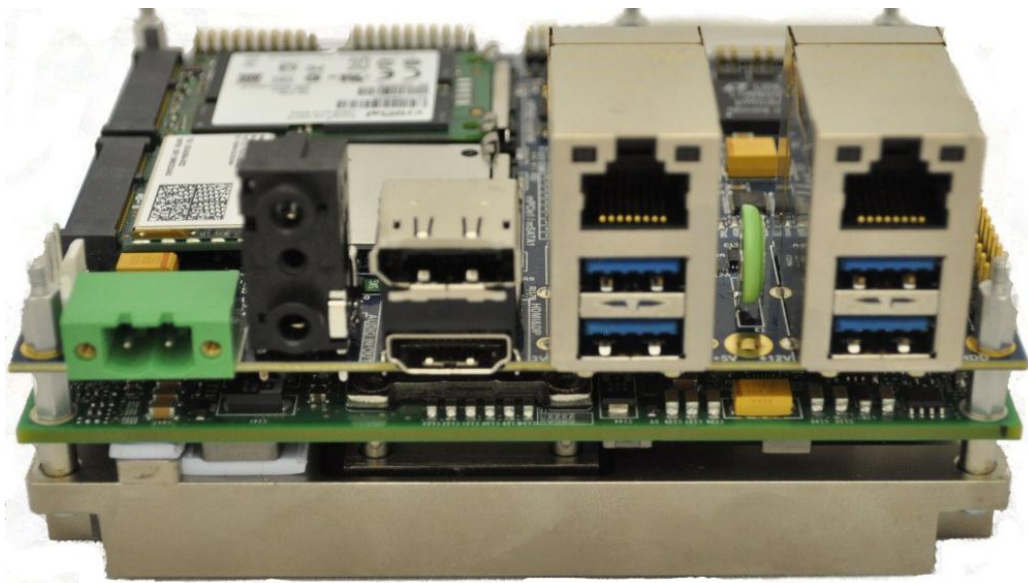

Connect Tech Inc.
42 Arrow Road
Guelph, Ontario
N1K 1S6

Tel: 519-836-1291
Toll: 800-426-8979 (North America only)
Fax: 519-836-4878
Email: sales@connecttech.com
support@connecttech.com
Web: www.connecttech.com

Table of Contents

Customer Support Overview	4
Contact Information.....	4
Limited Lifetime Warranty.....	5
Copyright Notice	5
Trademark Acknowledgment	5
Revision History	5
Introduction	6
ESD Warning.....	6
Product Features and Specifications	7
Block Diagram	8
Connector Locations.....	9
Top View	9
Front Panel View	9
Bottom View.....	10
Jumper and Connector Summary	10
Detailed Feature Pinouts and Descriptions.....	11
COM Express Module Connector.....	11
CPU Fan Connector	11
Input Power.....	12
Video Outputs.....	13
HDMI and Display Port	13
HDMI Connector	13
LVDS Video	14
Description.....	14
LVDS Video Header.....	14
LVDS Backlight Power Connector.....	15
LVDS Backlight Power Jumper.....	15
LVDS Panel LEDADJ Selection Jumper.....	15
VGA.....	16
VGA Pinouts.....	16
USB 3.0.....	17
Connector.....	17
10/100/1000 Ethernet.....	18
10/100/1000 Ethernet RJ Connector	18
Software Support for the Intel 82574.....	18
USB 2.0.....	19
USB 2.0 Internal Connector.....	19
Audio Interface	20
Audio Connectors	20
Software Support for the CS4207	20
External SATA Ports	21
SATA HDD Connectors	21
SATA HDD Power Connectors	21
miniPCIe & mSATA Slots.....	22
Dual Function miniPCIe mSATA Slots	22
Half and Full Length mini PCIe / mSATA module Installation	22

Asynchronous Serial Ports	24
Software Support for the Exar 17V358	24
Serial Connector RS-232	24
Serial Connector RS-422/485	25
RS485 Control Jumpers	25
GPIO and Console Serial Port.....	26
GPIO / Serial Console Connector	26
SD Card	27
Micro SD Card Connector	27
Multifunction Jumper Block	28
Miscellaneous Control Header.....	29
Typical Hardware Installation for +12V power input	30
Current Consumption Details	31
Mechanical Details	32
Cables & Interconnect	33
Appendix A – COM Express Signal/Pinout Connection Details.....	34

Customer Support Overview

If you experience difficulties after reading the manual and/or using the product, contact the Connect Tech reseller from which you purchased the product. In most cases the reseller can help you with product installation and difficulties.

In the event that the reseller is unable to resolve your problem, our highly qualified support staff can assist you. Our support section is available 24 hours a day, 7 days a week on our website at: www.connecttech.com/sub/support/support.asp. See the contact information section below for more information on how to contact us directly. Our technical support is always free.

Contact Information

Mail/Courier

Connect Tech Inc.
Technical Support
42 Arrow Road
Guelph, Ontario
Canada N1K 1S6

Email/Internet

sales@connecttech.com
support@connecttech.com
www.connecttech.com

Note:

Please go to the [Download Zone](#) or the [Knowledge Database](#) in the [Support Center](#) on the Connect Tech website for product manuals, installation guides, device driver software and technical tips. Submit your technical support questions to our customer support engineers via the [Support Center](#) on the Connect Tech website.

Telephone/Facsimile

Technical Support representatives are ready to answer your call Monday through Friday, from 8:30 a.m. to 5:00 p.m. Eastern Standard Time. Our numbers for calls are:

Toll Free: 800-426-8979 (North America only)

Telephone: 519-836-1291 (Live assistance available 8:30 a.m. to 5:00 p.m. EST,
Monday to Friday)

Facsimile: 519-836-4878 (on-line 24 hours)

Limited Lifetime Warranty

Connect Tech Inc. provides a Lifetime Warranty for all Connect Tech Inc. products. Should this product, in Connect Tech Inc.'s opinion, fail to be in good working order during the warranty period, Connect Tech Inc. will, at its option, repair or replace this product at no charge, provided that the product has not been subjected to abuse, misuse, accident, disaster or non-Connect Tech Inc. authorized modification or repair.

You may obtain warranty service by delivering this product to an authorized Connect Tech Inc. business partner or to Connect Tech Inc. along with proof of purchase. Product returned to Connect Tech Inc. must be pre-authorized by Connect Tech Inc. with an RMA (Return Material Authorization) number marked on the outside of the package and sent prepaid, insured and packaged for safe shipment. Connect Tech Inc. will return this product by prepaid ground shipment service.

The Connect Tech Inc. Lifetime Warranty is defined as the serviceable life of the product. This is defined as the period during which all components are available. Should the product prove to be irreparable, Connect Tech Inc. reserves the right to substitute an equivalent product if available or to retract Lifetime Warranty if no replacement is available.

The above warranty is the only warranty authorized by Connect Tech Inc. Under no circumstances will Connect Tech Inc. be liable in any way for any damages, including any lost profits, lost savings or other incidental or consequential damages arising out of the use of, or inability to use, such product.

Copyright Notice

The information contained in this document is subject to change without notice. Connect Tech Inc. shall not be liable for errors contained herein or for incidental consequential damages in connection with the furnishing, performance, or use of this material. This document contains proprietary information that is protected by copyright. All rights are reserved. No part of this document may be photocopied, reproduced, or translated to another language without the prior written consent of Connect Tech, Inc.

Copyright © 2013 by Connect Tech, Inc.

Trademark Acknowledgment

Connect Tech, Inc. acknowledges all trademarks, registered trademarks and/or copyrights referred to in this document as the property of their respective owners.

Not listing all possible trademarks or copyright acknowledgments does not constitute a lack of acknowledgment to the rightful owners of the trademarks and copyrights mentioned in this document.

Revision History

Revision	Date	Changes
0.00	01/08/2013	Original
0.01	02/22/2013	Updated miniPCIe/mSATA section, to explain jumper configuration
0.02	04/01/2013	Updated block diagram, added Micro SD Card Section
0.03	07/04/2013	Added Appendix A - COM Express Signal/Pinout Connection Details
0.04	11/06/2013	Updated Block Diagram to detail connections from COM Express

Introduction

Connect Tech's COM Express Carrier Boards are small feature rich, super flexible carrier boards that integrate with any industry standard Type 6 COM Express module. These bus-independent carrier boards offer easy connection to SATA HDD, USB 2 and USB 3, Audio, Dual Ethernet, HDMI, Display Port Video, LVDS Video, VGA video, RS232 and RS485 serial.

Connect Tech's COM Express carrier boards are ideal for compact and high performance computing applications in mobile entertainment, kiosks, digital signage, automation, ROVs and gaming applications.

ESD Warning



Electronic components and circuits are sensitive to ElectroStatic Discharge (ESD). When handling any circuit board assemblies including Connect Tech COM Express carrier assemblies, it is recommended that ESD safety precautions be observed. ESD safe best practices include, but are not limited to:

- Leaving circuit boards in their antistatic packaging until they are ready to be installed.
- Using a grounded wrist strap when handling circuit boards, at a minimum you should touch a grounded metal object to dissipate any static charge that may be present on you.
- Only handling circuit boards in ESD safe areas, which may include ESD floor and table mats, wrist strap stations and ESD safe lab coats.
- Avoiding handling circuit boards in carpeted areas.
- Try to handle the board by the edges, avoiding contact with components.

Product Features and Specifications

Feature	CCG008
PCB Size / Overall Size	125mm x 95mm (COM Express Basic Size) Maximum Top Side Component Height: 32mm 3D STEP Model: download here
Gigabit Ethernet	2
LVDS Video & Backlight power	Y
HDMI Video	Y
DisplayPort Video	Y
VGA	Y
3.5mm Audio Connector	1 Stereo Input / 1 Stereo Output
Dual mode mSATA/MiniPCle	2
SIM Card Slot	1
USB 3.0 Ports	4
USB 2.0 Ports	2
SATA HDD connector	2
SATA HDD power connector	2
GPIO or Micro SD	Y ^[1]
Power Connector	2 Position screw terminal
Standard Serial	2x RS232 and 2x RS485 ^[1]
Console Serial Port	1x RS232 basic port ^[1]
CMOS / RTC 3.3V Battery	Y
Accessories	Optional Cable Kit (SATA HDD/Power Cable, VGA, Serial)
Operating Temperature	-40 to +85 Celsius
Power Input	+12V +/- 5%
Weight	165 grams (carrier only, no module installed)
Warranty and Support	Lifetime warranty and free technical support

^[1] Jumper Selectable.

Block Diagram

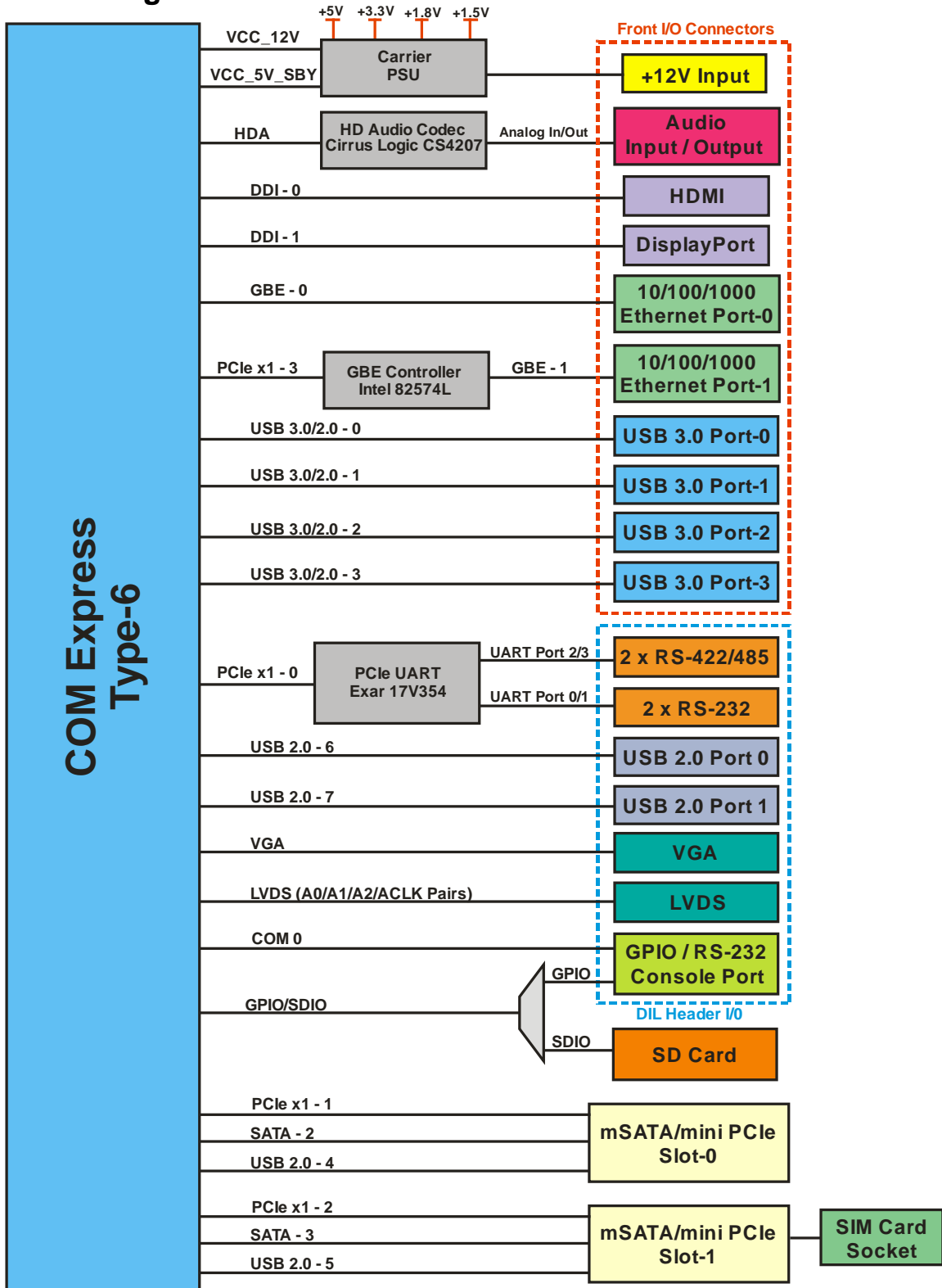

Connector Locations

Top View

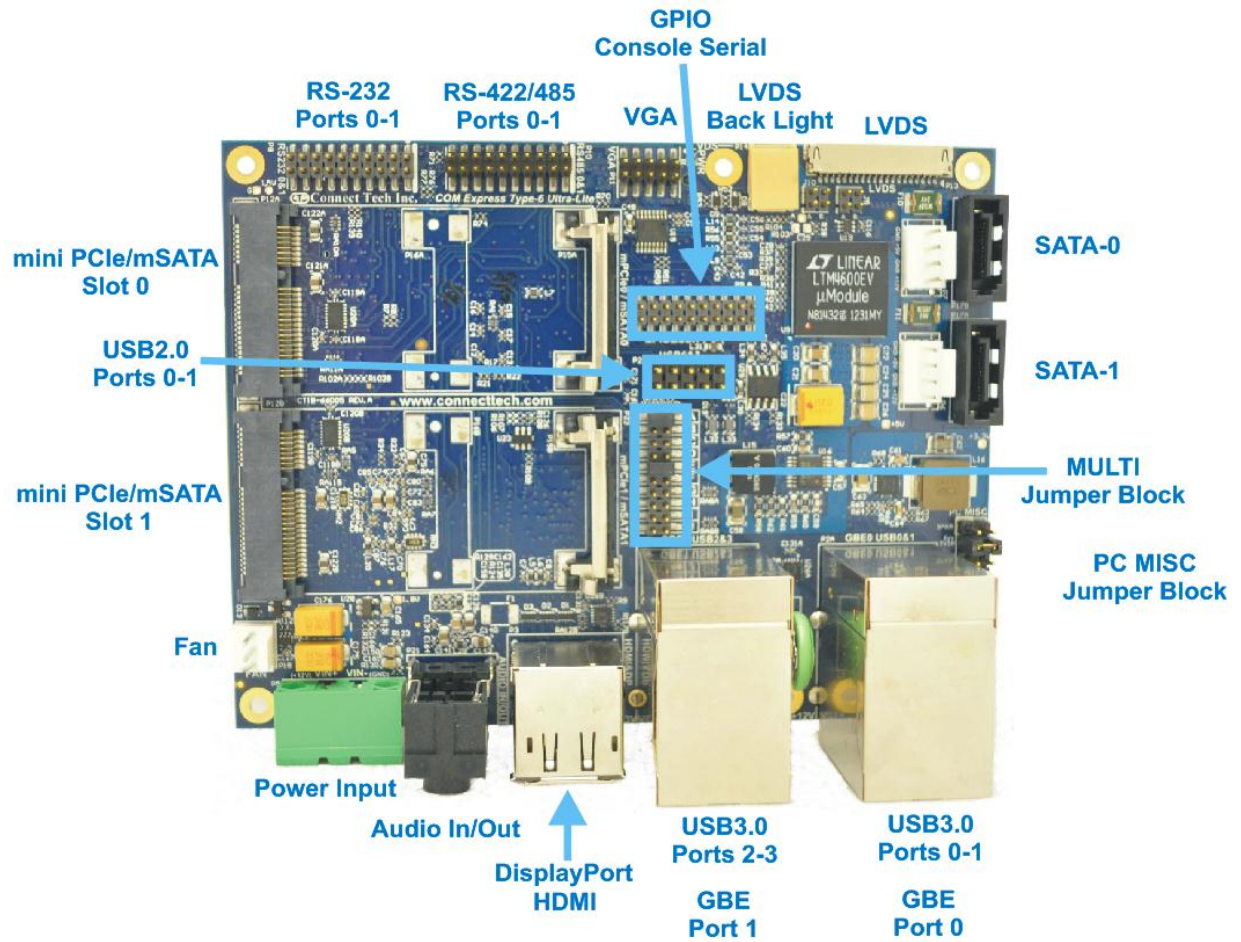

Front Panel View

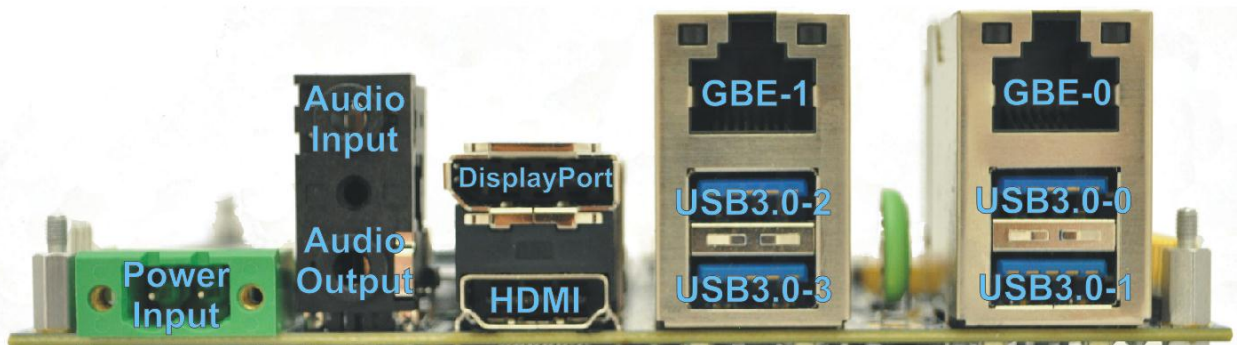

Bottom View

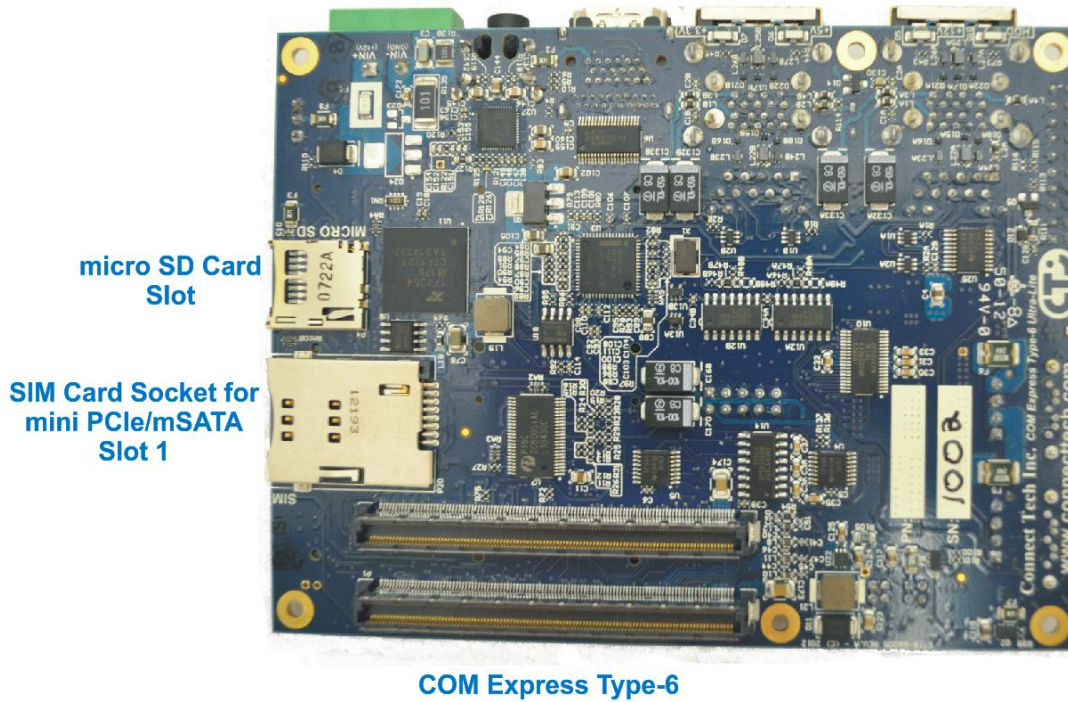

Jumper and Connector Summary

Designator	Connector	Description
P1	COM Ex	COM Express Connector,
P2A	USB / RJ45	USB3 Ports 0&1 and GBE 0
P2B	USB / RJ45	USB3 Ports 2&3 and GBE 1
P3	DP / HDMI	Display Port and HDMI
P4	Micro SD	Micro SD card.
P5	Screw Term	+12VDC Power In
P6, P7	4x1 0.1"	SATA Power
P8	2x10 2mm	RS232 Ports 1&2
P9	2x10 2mm	GPIO and COM Express Type 6 simple serial
P10	2x10 2mm	RS485 Ports 3&4
P11	2x5 2mm	VGA
P12A, P12B	MiniPCIe	Dual mode MiniPCIe / mSATA
P13		LVDS
P14	R/A	LVDS Backlight power
P17A, P17B		SATA Signal Ports 1&2
P18	1x3 0.1"	CPU FAN Power
P19	2x20 0.1"	Reset, #S3, I2C, Power Button Misc
P20	Mini SIM	Mini SIM card connector
P21	2x3.5mm phono	Stereo Audio In and Out
P22	2x5 0.1"	2 x USB2.0 Internal Connector
P23		Misc Controls

Detailed Feature Pinouts and Descriptions

COM Express Module Connector

The processor and chipset are implemented on the COM Express Type 6 CPU module, which connects to the COM Express carrier via a Tyco fine pitch stacking connector.

Function	COM Express interface	
Location	P1	
Type	Tyco fine pitch stacking connector, part number: 3-5353652-6 8mm stack height.	
Pinout	Refer to COM Express R2.0 specification, Type-6.	

Note: 8mm standoffs are required to mount COM Express module.

CPU Fan Connector

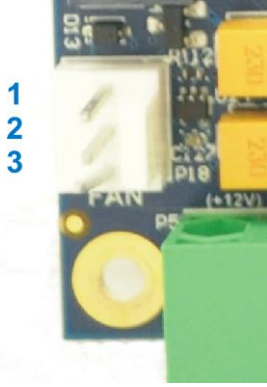
Function	Fan Power								
Location	P18								
Type	Molex: 22-23-2031								
Pinout	<table border="1" data-bbox="483 1125 691 1272"> <thead> <tr> <th>Pin</th> <th>Signal</th> </tr> </thead> <tbody> <tr> <td>1</td> <td>Fan Tach</td> </tr> <tr> <td>2</td> <td>+V</td> </tr> <tr> <td>3</td> <td>GND</td> </tr> </tbody> </table>		Pin	Signal	1	Fan Tach	2	+V	3
Pin	Signal								
1	Fan Tach								
2	+V								
3	GND								

Input Power

The COM Express carrier is designed to be powered from a regulated single +12V power supply.

The carrier board features a 5mm screw terminal style connector.

The COM Express carrier generates all of the necessary voltages on board from this single input.

A Panasonic BR1225A/FA Lithium battery provides the VBAT for the RTC Clock of the COM Express module.

Function	Main Input Power		
Location	P5		
Range	11.4 VDC to 12.6 VDC (+/-5%). Recommend no less than 12VDC at terminal block input.		
Type	2 Position terminal connector, mating PN: 20020111-G021A01LF		
Fuse	+12V is protected with a one-time 10A fuse, at F4.		
Pinout	Pin	Signal	Description
	1	+12V	Power In
	2	GND	Power Return
*DO NOT REVERSE POLARITY!			

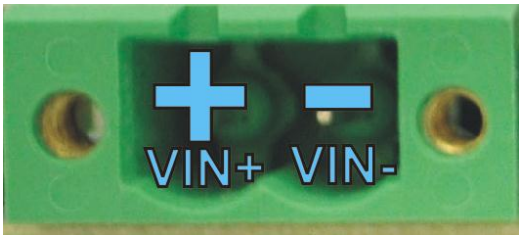
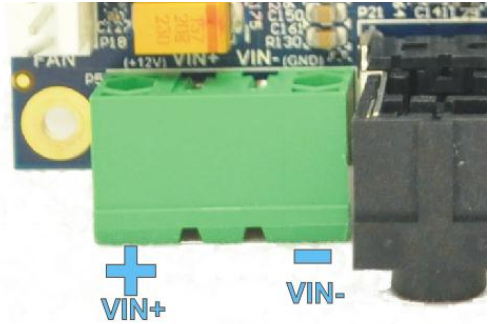
Video Outputs

The COM Express carrier features up to four video outputs, VGA, HDMI, Display Port and LVDS. The availability of the graphics interfaces depends on your Type 6 COM Express module.

The configuration of either interface as the primary or secondary or tertiary display depends on the COM Express module's BIOS capabilities and settings. Refer to the COM Express module's documentation for more details.

HDMI and Display Port

A stacked HDMI and Display Port connector is provided on the COM Express carrier.

HDMI Connector

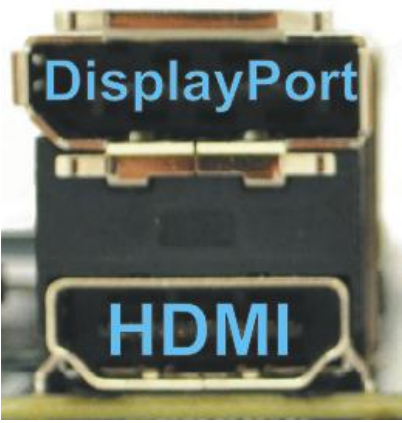
Function	HDMI and Display Port	
Location	P3	
Type	Standard HDMI and Display Port	

Note: Revision A CCG008 carrier boards have HDMI functionality disabled. HDMI can be used for prototyping on these carrier boards through the use of a DisplayPort to HDMI Adapter.

LVDS Video

Description

The COM Express carrier provides dual 18 or 24 bit LVDS display channels via P4, which are connected directly from the COM Express module. LVDS panel supply power is selected with jumper J1 and backlight power is selected with jumper J2. Both are current limited to 500 mA with Raychem resettable poly fuses.

LVDS Video Header

Function	LVDS Graphics		
Location	P13		
Type	Board Connector: Hirose DF19G-20P-1H(54) Mating Connector: Hirose DF19-20S-1C		
Pinout	Pin	Signal	Description
	1	+3.3 VCC_PNL	Panel Power
	2	+3.3 VCC_PNL	Panel Power
	3	GND	Digital ground
	4	GND	Digital ground
	5	LVDS_A0_N	Channel A Data
	6	LVDS_A0_P	Channel A Data
	7	GND	Digital ground
	8	LVDS_A1_N	Channel A Data
	9	LVDS_A1_P	Channel A Data
	10	GND	Digital ground
	11	LVDS_A2_N	Channel A Data
	12	LVDS_A2_P	Channel A Data
	13	GND	Digital ground
	14	LVDS_CLK_N	Channel A Data
	15	LVDS_CLK_P	Channel A Data
	16	GND	Digital ground
	17	+5 VCC_PNL	Backlight Power
	18	+5 VCC_PNL	Backlight Power
	19	GND	Digital ground
20	BKLT Control / GND	LED ADJ	



LVDS Video Cabling Solutions

Mating Plug Connector: Hirose DF19-20S-1C
Pre-terminated Wires: Hirose CASS-0841

OEM Cable Assembly Solutions

Axon-Cable: http://www.axon-cable.com/pdf/FDC_Flat_Display_Connections.pdf
Esskabel: http://www.esskabel.de/upload/files/pdf/KAB-DF19G-20S-0500RK_EN.pdf
FS-Net: <http://www.fs-net.de/cms/index.php?id=465&L=1>

LVDS Backlight Power Connector

Function	LVDS backlight Inverter power							
Location	P14							
Type	JST SM02B-BHSS-1-TB(LF)(SN) connector							
Pinout	<table border="1"> <thead> <tr> <th>Pin</th> <th>Signal</th> </tr> </thead> <tbody> <tr> <td>1</td> <td>VA LED</td> </tr> <tr> <td>2</td> <td>VK LED</td> </tr> </tbody> </table>	Pin	Signal	1	VA LED	2	VK LED	
Pin	Signal							
1	VA LED							
2	VK LED							



Designed to power HDA700LPT-GHL which has 13 parallel strings of 3 series white LEDs. Each white LED has a Vf of around 3.3V.

LVDS Backlight Power Jumper

Function	LVDS backlight power select You can optionally connect +5V to pins 17 & 18 of the LVDS Video connector. Some LVDS displays require this for backlight powering, others require external backlight power to be sourced from P14.					
Location	J5					
Type	2x2 2mm jumper block					
Pinout	<table border="1"> <thead> <tr> <th>Position</th> <th>Description</th> </tr> </thead> <tbody> <tr> <td>J5A / J5B</td> <td>+5V BKL</td> </tr> </tbody> </table>	Position	Description	J5A / J5B	+5V BKL	
Position	Description					
J5A / J5B	+5V BKL					
Default	off					

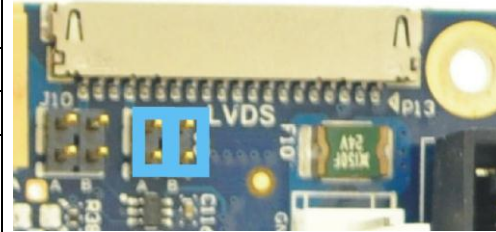

LVDS Panel LEDADJ Selection Jumper

Function	LVDS panel power select							
Location	J10							
Type	1x3 0.100" jumper block							
Pinout	<table border="1"> <thead> <tr> <th>Position</th> <th>Description</th> </tr> </thead> <tbody> <tr> <td>J10A</td> <td>Disable / (or off)</td> </tr> <tr> <td>J10B</td> <td>Enable Control</td> </tr> </tbody> </table>	Position	Description	J10A	Disable / (or off)	J10B	Enable Control	
Position	Description							
J10A	Disable / (or off)							
J10B	Enable Control							
Default	Off or position A							



VGA

The carrier boards brings the VGA video output to a 2x5 2mm header. This header can be mated to Connect Tech's CBG070 cable which then terminates to a standard DB-15 VGA connector which is panel mountable.

VGA Pinouts

Function	Standard VGA																							
Location	P11																							
Type	2x5 2mm pitch header																							
Pinout	<table border="1"> <thead> <tr> <th>Pin</th> <th>Description</th> </tr> </thead> <tbody> <tr> <td>1</td> <td>Red</td> </tr> <tr> <td>2</td> <td>GND</td> </tr> <tr> <td>3</td> <td>Green</td> </tr> <tr> <td>4</td> <td>NC</td> </tr> <tr> <td>5</td> <td>Blue</td> </tr> <tr> <td>6</td> <td>SC DDC</td> </tr> <tr> <td>7</td> <td>HSYNC</td> </tr> <tr> <td>8</td> <td>SD DDC</td> </tr> <tr> <td>9</td> <td>VSYNC</td> </tr> <tr> <td>10</td> <td>GND</td> </tr> </tbody> </table>		Pin	Description	1	Red	2	GND	3	Green	4	NC	5	Blue	6	SC DDC	7	HSYNC	8	SD DDC	9	VSYNC	10	GND
	Pin	Description																						
	1	Red																						
	2	GND																						
	3	Green																						
	4	NC																						
	5	Blue																						
	6	SC DDC																						
	7	HSYNC																						
	8	SD DDC																						
	9	VSYNC																						
10	GND																							
Optional Cable	CBG070																							

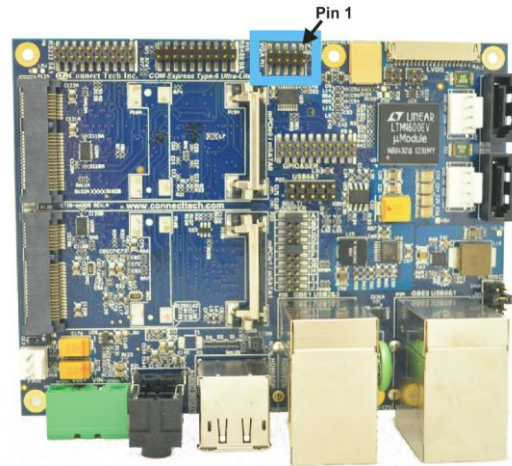

USB 3.0

The COM Express carrier implements four USB 3.0 connections via two USB connectors. Over current protection, power supply filtering and ESD protection is provided.

Each USB 3.0 port is capable of bitrates of up to 5Gbps, as well as accepting USB2.0 and below connections.

Connector

Function	USB 3.0	
Locations	P2A, P2B	
Type	Standard Dual USB 3.0 jacks	
Pinout	Pin	Description
	1	VBUS
	2	D-
	3	D+
	4	GND
	5	SSRX-
	6	SSRX+
	7	GND
	8	SSTX-
9	SSTX+	

10/100/1000 Ethernet

The COM Express carrier features dual 10/100/1000 Ethernet Ports.

GBE Port 0 is coming from an Intel 82574 PCIe PHY Controller located on the carrier.

GBE Port 1 is coming directly from the the COM Express module.

10/100/1000 Ethernet RJ Connector

Function	LAN Connector																			
Locations	P2A, P2B																			
Type	Standard 8 position RJ connector																			
Pinout	<table border="1" style="width: 100%;"> <thead> <tr> <th>Pin</th> <th>Signal</th> </tr> </thead> <tbody> <tr><td>1</td><td>MX1P</td></tr> <tr><td>2</td><td>MX1N</td></tr> <tr><td>3</td><td>MX2P</td></tr> <tr><td>6</td><td>MX2N</td></tr> <tr><td>4</td><td>MX3P</td></tr> <tr><td>5</td><td>MX3N</td></tr> <tr><td>7</td><td>MX4P</td></tr> <tr><td>8</td><td>MX4N</td></tr> </tbody> </table>	Pin		Signal	1	MX1P	2	MX1N	3	MX2P	6	MX2N	4	MX3P	5	MX3N	7	MX4P	8	MX4N
Pin	Signal																			
1	MX1P																			
2	MX1N																			
3	MX2P																			
6	MX2N																			
4	MX3P																			
5	MX3N																			
7	MX4P																			
8	MX4N																			

Software Support for the Intel 82574

Additional drivers will be needed to properly operate the GBE Port 0 on the COM Express carrier.

These drivers can be downloaded directly from Intel website from the below link:

<http://downloadcenter.intel.com/SearchResult.aspx?lang=eng&ProductFamily=Ethernet+Components&ProductLine=Ethernet+Controllers&ProductProduct=Intel%C2%AE+82574+Gigabit+Ethernet+Controller>

USB 2.0

The COM Express Ultra-Lite carrier provides two USB 2.0 “internal” connections via a standardized 2x5 0.1” pitch IDC header. This header can be mated to any standardized motherboard type dual USB to panel cabling.

USB 2.0 Internal Connector

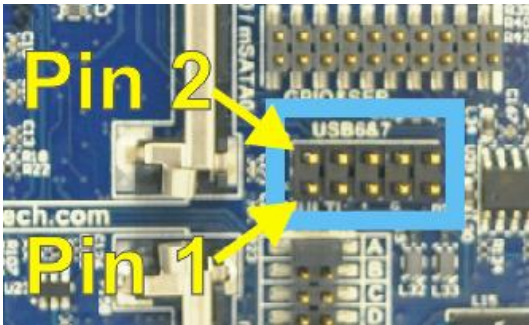
Function	USB 2.0																							
Locations	P2A, P2B																							
Type	Standard Dual USB 3.0 jacks																							
Pinout	<table border="1"> <thead> <tr> <th>Pin</th> <th>Description</th> </tr> </thead> <tbody> <tr> <td>1</td> <td>VBUS Port 0</td> </tr> <tr> <td>2</td> <td>VBUS Port 1</td> </tr> <tr> <td>3</td> <td>Port-0 D-</td> </tr> <tr> <td>4</td> <td>Port-1 D-</td> </tr> <tr> <td>5</td> <td>Port-0 D+</td> </tr> <tr> <td>6</td> <td>Port-1 D+</td> </tr> <tr> <td>7</td> <td>GND</td> </tr> <tr> <td>8</td> <td>GND</td> </tr> <tr> <td>9</td> <td>NC</td> </tr> <tr> <td>10</td> <td>NC</td> </tr> </tbody> </table>	Pin	Description	1	VBUS Port 0	2	VBUS Port 1	3	Port-0 D-	4	Port-1 D-	5	Port-0 D+	6	Port-1 D+	7	GND	8	GND	9	NC	10	NC	
Pin	Description																							
1	VBUS Port 0																							
2	VBUS Port 1																							
3	Port-0 D-																							
4	Port-1 D-																							
5	Port-0 D+																							
6	Port-1 D+																							
7	GND																							
8	GND																							
9	NC																							
10	NC																							

Audio Interface

The COM Express Carrier features two 3.5mm stereo audio jacks, one input and one output. The audio codec used on the carrier board is the CS4207 from Cirrus Logic.

Audio Connectors

Function	Audio Input	Audio Output
Location	P21 (“Top”)	P21 (“Bottom”)
Details	Stereo Audio Input OS: “Microphone In”	Stereo Audio Output OS: “Headphone Out”
Type	3.5mm Stereo Jacks	

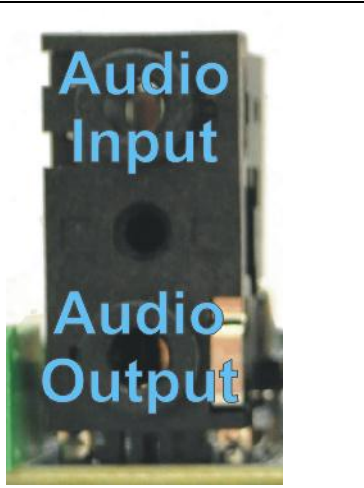

Notes:

1. The Microphone input is equipped with a Phantom Power circuit.
2. The Headphone output is amplified by the CS4207 Codec.

Some operating systems may not properly register the input sense detection from the CS4207 audio codec.

Software Support for the CS4207

Additional drivers will be needed to properly operate audio on the COM Express carrier. Some downloadable links can be found below.

Windows XP Driver: http://www.cirrus.com/en/pubs/software/CS4207_WinXP_1-0-0-38.zip

Windows 7/Vista Driver: http://www.cirrus.com/en/pubs/software/CS4207_WinVista_Win7_32-64-bit_6-6001-1-30.zip

Linux Driver: Included in kernels 2.6.30 and up.

External SATA Ports

The COM Express carrier provides two SATA HDD connections as well as external power connectors for each drive.

SATA HDD Connectors

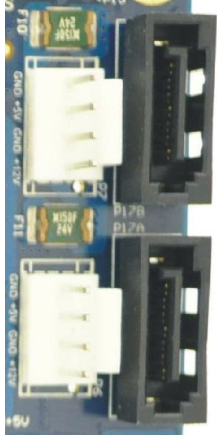
Function	SATA host																	
Locations	P17A – SATA – 0 P17B – SATA – 1																	
Type	Industry standard vertical entry SATA host connector with locking.																	
Pinout	<table border="1" style="width: 100%;"> <thead> <tr> <th>Pin</th> <th>Signal</th> </tr> </thead> <tbody> <tr> <td>1</td> <td>GND</td> </tr> <tr> <td>2</td> <td>SATA_TX_P</td> </tr> <tr> <td>3</td> <td>SATA_TX_N</td> </tr> <tr> <td>4</td> <td>GND</td> </tr> <tr> <td>5</td> <td>SATA_RX_N</td> </tr> <tr> <td>6</td> <td>SATA_RX_P</td> </tr> <tr> <td>7</td> <td>GND</td> </tr> </tbody> </table>			Pin	Signal	1	GND	2	SATA_TX_P	3	SATA_TX_N	4	GND	5	SATA_RX_N	6	SATA_RX_P	7
Pin	Signal																	
1	GND																	
2	SATA_TX_P																	
3	SATA_TX_N																	
4	GND																	
5	SATA_RX_N																	
6	SATA_RX_P																	
7	GND																	

SATA HDD Power Connectors

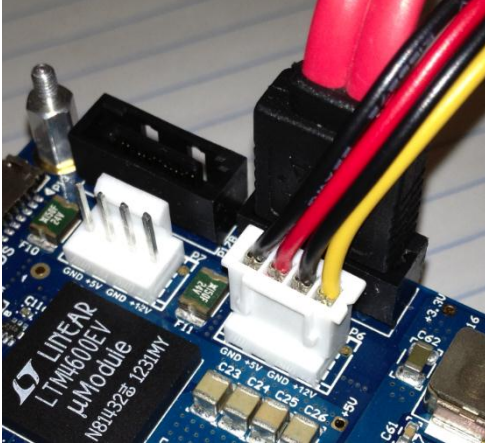
Function	SATA HDD Power											
Locations	P6, P7											
Type	4 Pos 0.100" connector Can be mated to any 0.1" cable assembly, or Connect Tech's CBG090 cable which ships in the CCG008 cable kit.											
Pinout	<table border="1" style="width: 100%;"> <thead> <tr> <th>Pin</th> <th>Signal</th> </tr> </thead> <tbody> <tr> <td>1</td> <td>GND (Black)</td> </tr> <tr> <td>2</td> <td>+5V (Red)</td> </tr> <tr> <td>3</td> <td>GND (Black)</td> </tr> <tr> <td>4</td> <td>+12V (Yellow)</td> </tr> </tbody> </table> <p>+12V and +5V are protected with 1200mA Raychem Poly fuses.</p>			Pin	Signal	1	GND (Black)	2	+5V (Red)	3	GND (Black)	4
Pin	Signal											
1	GND (Black)											
2	+5V (Red)											
3	GND (Black)											
4	+12V (Yellow)											

SATA Port 0 shown installed with CBG090 SATA/Power Cable

Note: The SATA power connectors are fused independently from the main +12V fuse that provides +12V power to the board, i.e. the SATA power connectors are not double fused.

Important Note: The power connector can be accidentally plugged in, in the wrong orientation, please ensure the cable is plugged in as you see in the above photo.

miniPCIe & mSATA Slots

Dual Function miniPCIe mSATA Slots

The COM Express Ultra-Lite has two special dual purpose functionality mini PCIe / mSATA slots. Each of these slots can accept either a mini PCIe module or a mSATA SSD module. These slots have special circuitry that allows for the selection between connecting PCIe lanes or SATA lanes.

Each of these slots are also provided with a USB 2.0 in addition to the PCIe as per the mini PCIe specification, see below for a block diagram of the slots functionality.

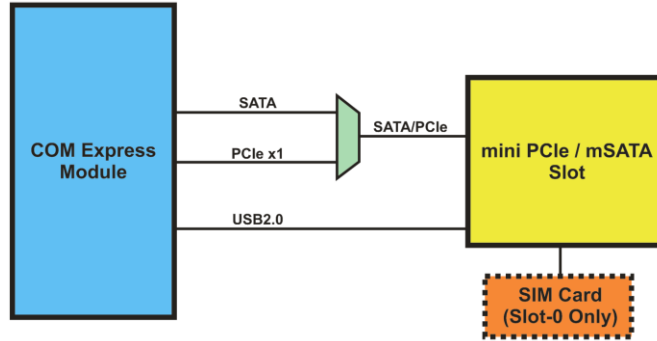

PCIe / SATA Dual Functionality Diagram

Selection between mSATA and miniPCIe is done on the MULTI-JUMPER block (P23)

Position	Jumper ON	Jumper OFF
C	Slot-0 miniPCIe selected	Slot-0 mSATA selected
D	Slot-1 miniPCIe selected	Slot-1 mSATA selected

Half and Full Length mini PCIe / mSATA module Installation

The COM Express Ultra-Lite come populated by default with its latches in the full length position. If you wish install a half-length module you must use a half-to-full length bracket like shown below. If you would prefer to have a slot or both populated with half at the time of your production order please contact sales@connecttech.com for further details.



Function	mini PCIe / mSATA Slots																																																																																																																																																																																																																				
Locations	P12A, P12B																																																																																																																																																																																																																				
Type	4 Pos 0.100" connector Can be mated to any 0.1" cable assembly, or Connect Tech's CBG090 cable which ships in the CCG008 cable kit.																																																																																																																																																																																																																				
Pinout	mSATA Pinout	miniPCIe Pinout																																																																																																																																																																																																																			
	<table border="1"> <thead> <tr> <th>Pin Number</th> <th>Description</th> </tr> </thead> <tbody> <tr><td>1</td><td>NC</td></tr> <tr><td>2</td><td>+3.3V</td></tr> <tr><td>3</td><td>NC</td></tr> <tr><td>4</td><td>GND</td></tr> <tr><td>5</td><td>NC</td></tr> <tr><td>6</td><td>+1.5V</td></tr> <tr><td>7</td><td>NC</td></tr> <tr><td>8</td><td>NC</td></tr> <tr><td>9</td><td>GND</td></tr> <tr><td>10</td><td>NC</td></tr> <tr><td>11</td><td>NC</td></tr> <tr><td>12</td><td>NC</td></tr> <tr><td>13</td><td>NC</td></tr> <tr><td>14</td><td>NC</td></tr> <tr><td>15</td><td>GND</td></tr> <tr><td>16</td><td>NC</td></tr> <tr><td>17</td><td>NC</td></tr> <tr><td>18</td><td>GND</td></tr> <tr><td>19</td><td>NC</td></tr> <tr><td>20</td><td>NC</td></tr> <tr><td>21</td><td>RESV</td></tr> <tr><td>22</td><td>NC</td></tr> <tr><td>23</td><td>SATA TX+ To Host System</td></tr> <tr><td>24</td><td>+3.3V</td></tr> <tr><td>25</td><td>SATA TX- To Host System</td></tr> <tr><td>26</td><td>GND</td></tr> <tr><td>27</td><td>GND</td></tr> <tr><td>28</td><td>+1.5V</td></tr> <tr><td>29</td><td>GND</td></tr> <tr><td>30</td><td>NC</td></tr> <tr><td>31</td><td>SATA RX- From Host System</td></tr> <tr><td>32</td><td>NC</td></tr> <tr><td>33</td><td>SATA RX+ From Host System</td></tr> <tr><td>34</td><td>GND</td></tr> <tr><td>35</td><td>GND</td></tr> <tr><td>36</td><td>NC</td></tr> <tr><td>37</td><td>GND</td></tr> <tr><td>38</td><td>NC</td></tr> <tr><td>39</td><td>+3.3V</td></tr> <tr><td>40</td><td>GND</td></tr> <tr><td>41</td><td>+3.3V</td></tr> <tr><td>42</td><td>NC</td></tr> <tr><td>43</td><td>RESV</td></tr> <tr><td>44</td><td>NC</td></tr> <tr><td>45</td><td>NC</td></tr> <tr><td>46</td><td>NC</td></tr> <tr><td>47</td><td>NC</td></tr> <tr><td>48</td><td>+1.5V</td></tr> <tr><td>49</td><td>NC</td></tr> <tr><td>50</td><td>GND</td></tr> <tr><td>51</td><td>NC</td></tr> <tr><td>52</td><td>+3.3V</td></tr> </tbody> </table>	Pin Number	Description	1	NC	2	+3.3V	3	NC	4	GND	5	NC	6	+1.5V	7	NC	8	NC	9	GND	10	NC	11	NC	12	NC	13	NC	14	NC	15	GND	16	NC	17	NC	18	GND	19	NC	20	NC	21	RESV	22	NC	23	SATA TX+ To Host System	24	+3.3V	25	SATA TX- To Host System	26	GND	27	GND	28	+1.5V	29	GND	30	NC	31	SATA RX- From Host System	32	NC	33	SATA RX+ From Host System	34	GND	35	GND	36	NC	37	GND	38	NC	39	+3.3V	40	GND	41	+3.3V	42	NC	43	RESV	44	NC	45	NC	46	NC	47	NC	48	+1.5V	49	NC	50	GND	51	NC	52	+3.3V	<table border="1"> <thead> <tr> <th>Pin Number</th> <th>Description</th> </tr> </thead> <tbody> <tr><td>1</td><td>NC</td></tr> <tr><td>2</td><td>+3.3V</td></tr> <tr><td>3</td><td>NC</td></tr> <tr><td>4</td><td>GND</td></tr> <tr><td>5</td><td>NC</td></tr> <tr><td>6</td><td>+1.5V</td></tr> <tr><td>7</td><td>CLKREQ#</td></tr> <tr><td>8</td><td>UIM_PWR</td></tr> <tr><td>9</td><td>GND</td></tr> <tr><td>10</td><td>UIM_DATA</td></tr> <tr><td>11</td><td>PCIe CLK+</td></tr> <tr><td>12</td><td>UIM_CLK</td></tr> <tr><td>13</td><td>PCIe CLK-</td></tr> <tr><td>14</td><td>UIM_RESET</td></tr> <tr><td>15</td><td>GND</td></tr> <tr><td>16</td><td>UIM_VPP</td></tr> <tr><td>17</td><td>NC</td></tr> <tr><td>18</td><td>GND</td></tr> <tr><td>19</td><td>NC</td></tr> <tr><td>20</td><td>W_DISABLE#</td></tr> <tr><td>21</td><td>RESV</td></tr> <tr><td>22</td><td>NC</td></tr> <tr><td>23</td><td>PCIe RX+ To Host System</td></tr> <tr><td>24</td><td>+3.3V</td></tr> <tr><td>25</td><td>PCIe RX- To Host System</td></tr> <tr><td>26</td><td>GND</td></tr> <tr><td>27</td><td>GND</td></tr> <tr><td>28</td><td>+1.5V</td></tr> <tr><td>29</td><td>GND</td></tr> <tr><td>30</td><td>SMB_CLK</td></tr> <tr><td>31</td><td>PCIe TX- From Host System</td></tr> <tr><td>32</td><td>SMB_DATA</td></tr> <tr><td>33</td><td>PCIe TX+ From Host System</td></tr> <tr><td>34</td><td>GND</td></tr> <tr><td>35</td><td>GND</td></tr> <tr><td>36</td><td>USB D-</td></tr> <tr><td>37</td><td>GND</td></tr> <tr><td>38</td><td>USB D+</td></tr> <tr><td>39</td><td>+3.3V</td></tr> <tr><td>40</td><td>GND</td></tr> <tr><td>41</td><td>+3.3V</td></tr> <tr><td>42</td><td>NC</td></tr> <tr><td>43</td><td>RESV</td></tr> <tr><td>44</td><td>NC</td></tr> <tr><td>45</td><td>NC</td></tr> <tr><td>46</td><td>NC</td></tr> <tr><td>47</td><td>NC</td></tr> <tr><td>48</td><td>+1.5V</td></tr> <tr><td>49</td><td>NC</td></tr> <tr><td>50</td><td>GND</td></tr> <tr><td>51</td><td>NC</td></tr> <tr><td>52</td><td>+3.3V</td></tr> </tbody> </table>	Pin Number	Description	1	NC	2	+3.3V	3	NC	4	GND	5	NC	6	+1.5V	7	CLKREQ#	8	UIM_PWR	9	GND	10	UIM_DATA	11	PCIe CLK+	12	UIM_CLK	13	PCIe CLK-	14	UIM_RESET	15	GND	16	UIM_VPP	17	NC	18	GND	19	NC	20	W_DISABLE#	21	RESV	22	NC	23	PCIe RX+ To Host System	24	+3.3V	25	PCIe RX- To Host System	26	GND	27	GND	28	+1.5V	29	GND	30	SMB_CLK	31	PCIe TX- From Host System	32	SMB_DATA	33	PCIe TX+ From Host System	34	GND	35	GND	36	USB D-	37	GND	38	USB D+	39	+3.3V	40	GND	41	+3.3V	42	NC	43	RESV	44	NC	45	NC	46	NC	47	NC	48	+1.5V	49	NC	50	GND	51	NC	52
Pin Number	Description																																																																																																																																																																																																																				
1	NC																																																																																																																																																																																																																				
2	+3.3V																																																																																																																																																																																																																				
3	NC																																																																																																																																																																																																																				
4	GND																																																																																																																																																																																																																				
5	NC																																																																																																																																																																																																																				
6	+1.5V																																																																																																																																																																																																																				
7	NC																																																																																																																																																																																																																				
8	NC																																																																																																																																																																																																																				
9	GND																																																																																																																																																																																																																				
10	NC																																																																																																																																																																																																																				
11	NC																																																																																																																																																																																																																				
12	NC																																																																																																																																																																																																																				
13	NC																																																																																																																																																																																																																				
14	NC																																																																																																																																																																																																																				
15	GND																																																																																																																																																																																																																				
16	NC																																																																																																																																																																																																																				
17	NC																																																																																																																																																																																																																				
18	GND																																																																																																																																																																																																																				
19	NC																																																																																																																																																																																																																				
20	NC																																																																																																																																																																																																																				
21	RESV																																																																																																																																																																																																																				
22	NC																																																																																																																																																																																																																				
23	SATA TX+ To Host System																																																																																																																																																																																																																				
24	+3.3V																																																																																																																																																																																																																				
25	SATA TX- To Host System																																																																																																																																																																																																																				
26	GND																																																																																																																																																																																																																				
27	GND																																																																																																																																																																																																																				
28	+1.5V																																																																																																																																																																																																																				
29	GND																																																																																																																																																																																																																				
30	NC																																																																																																																																																																																																																				
31	SATA RX- From Host System																																																																																																																																																																																																																				
32	NC																																																																																																																																																																																																																				
33	SATA RX+ From Host System																																																																																																																																																																																																																				
34	GND																																																																																																																																																																																																																				
35	GND																																																																																																																																																																																																																				
36	NC																																																																																																																																																																																																																				
37	GND																																																																																																																																																																																																																				
38	NC																																																																																																																																																																																																																				
39	+3.3V																																																																																																																																																																																																																				
40	GND																																																																																																																																																																																																																				
41	+3.3V																																																																																																																																																																																																																				
42	NC																																																																																																																																																																																																																				
43	RESV																																																																																																																																																																																																																				
44	NC																																																																																																																																																																																																																				
45	NC																																																																																																																																																																																																																				
46	NC																																																																																																																																																																																																																				
47	NC																																																																																																																																																																																																																				
48	+1.5V																																																																																																																																																																																																																				
49	NC																																																																																																																																																																																																																				
50	GND																																																																																																																																																																																																																				
51	NC																																																																																																																																																																																																																				
52	+3.3V																																																																																																																																																																																																																				
Pin Number	Description																																																																																																																																																																																																																				
1	NC																																																																																																																																																																																																																				
2	+3.3V																																																																																																																																																																																																																				
3	NC																																																																																																																																																																																																																				
4	GND																																																																																																																																																																																																																				
5	NC																																																																																																																																																																																																																				
6	+1.5V																																																																																																																																																																																																																				
7	CLKREQ#																																																																																																																																																																																																																				
8	UIM_PWR																																																																																																																																																																																																																				
9	GND																																																																																																																																																																																																																				
10	UIM_DATA																																																																																																																																																																																																																				
11	PCIe CLK+																																																																																																																																																																																																																				
12	UIM_CLK																																																																																																																																																																																																																				
13	PCIe CLK-																																																																																																																																																																																																																				
14	UIM_RESET																																																																																																																																																																																																																				
15	GND																																																																																																																																																																																																																				
16	UIM_VPP																																																																																																																																																																																																																				
17	NC																																																																																																																																																																																																																				
18	GND																																																																																																																																																																																																																				
19	NC																																																																																																																																																																																																																				
20	W_DISABLE#																																																																																																																																																																																																																				
21	RESV																																																																																																																																																																																																																				
22	NC																																																																																																																																																																																																																				
23	PCIe RX+ To Host System																																																																																																																																																																																																																				
24	+3.3V																																																																																																																																																																																																																				
25	PCIe RX- To Host System																																																																																																																																																																																																																				
26	GND																																																																																																																																																																																																																				
27	GND																																																																																																																																																																																																																				
28	+1.5V																																																																																																																																																																																																																				
29	GND																																																																																																																																																																																																																				
30	SMB_CLK																																																																																																																																																																																																																				
31	PCIe TX- From Host System																																																																																																																																																																																																																				
32	SMB_DATA																																																																																																																																																																																																																				
33	PCIe TX+ From Host System																																																																																																																																																																																																																				
34	GND																																																																																																																																																																																																																				
35	GND																																																																																																																																																																																																																				
36	USB D-																																																																																																																																																																																																																				
37	GND																																																																																																																																																																																																																				
38	USB D+																																																																																																																																																																																																																				
39	+3.3V																																																																																																																																																																																																																				
40	GND																																																																																																																																																																																																																				
41	+3.3V																																																																																																																																																																																																																				
42	NC																																																																																																																																																																																																																				
43	RESV																																																																																																																																																																																																																				
44	NC																																																																																																																																																																																																																				
45	NC																																																																																																																																																																																																																				
46	NC																																																																																																																																																																																																																				
47	NC																																																																																																																																																																																																																				
48	+1.5V																																																																																																																																																																																																																				
49	NC																																																																																																																																																																																																																				
50	GND																																																																																																																																																																																																																				
51	NC																																																																																																																																																																																																																				
52	+3.3V																																																																																																																																																																																																																				



Asynchronous Serial Ports

The COM Express Ultra-Lite carrier features four “external” serial ports. Port1 and Port2 are standard RS-232 and Port3 and Port4 can be configured as RS-422/485. These serial ports are generated from on-board PCIe 4-port UART the Exar 17V358 (Connect Tech’s BlueStorm/Express Circuitry).

Software Support for the Exar 17V358

Additional drivers will be needed to properly operate the 4 additional serial ports on the COM Express carrier. Drivers for this functionality can be found on Connect Tech’s download zone here:
[http://www.connecttech.com/asp/Support/DownloadZone_results.asp?Product=3&OperatingSystem=IS+N
 OT+NULL&x=16&y=13](http://www.connecttech.com/asp/Support/DownloadZone_results.asp?Product=3&OperatingSystem=IS+N

 OT+NULL&x=16&y=13)

Serial Connector RS-232

Function	RS232 Serial		
Location	P8		
Type	2x10 2mm Header		
Pinout	Header Pin	Signal	DB9 Pin
	1	DCD	1
	2	DSR	6
	3	RXD	2
	4	RTS	7
	5	TXD	3
	6	CTS	8
	7	DTR	4
	8	RI	9
	9	GND	5
	10	No Connect	
	11	DCD	1
	12	DSR	6
	13	RXD	2
	14	RTS	7
	15	TXD	3
	16	CTS	8
	17	DTR	4
	18	RI	9
	19	GND	5
20	No Connect		

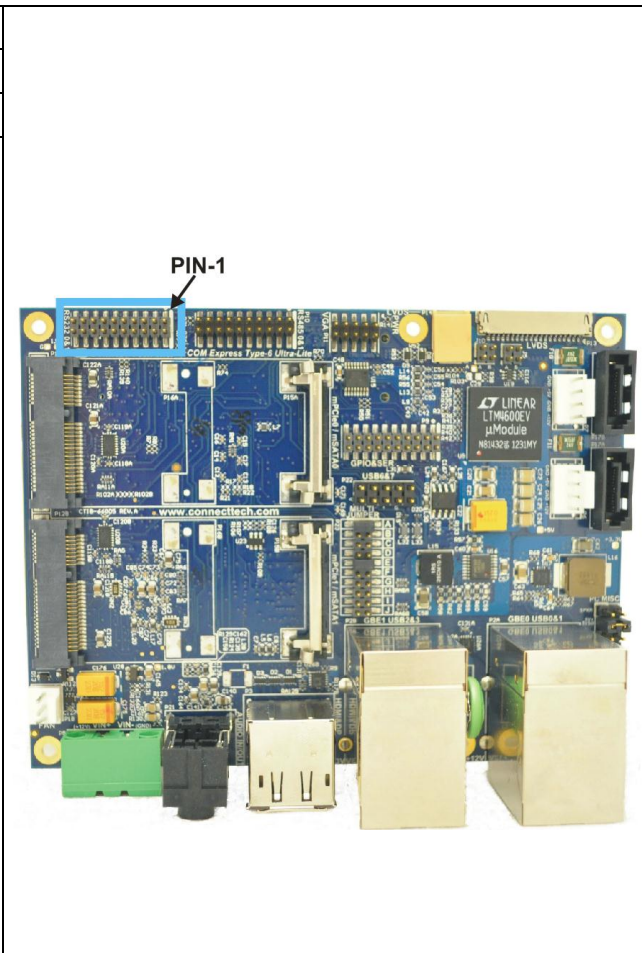

Serial Connector RS-422/485

Function	RS485 Serial		
Location	P10		
Type	2x10 2mm Header		
Pinout	Header Pin	Signal	DB9 Pin
	1	RXD+	1
	3	TXD+	2
	5	TXD-	3
	7	RXD-	4
	9	GND	5
	11	RXD+	1
	13	TXD+	2
	15	TXD-	3
	17	RXD-	4
19	GND	5	



RS485 Control Jumpers

The RS485 Control Jumpers are used for implementing the following RS485 modes of operations:

- ½ Duplex Multidrop
- Full Duplex Multidrop

The UART RTS signals can be used for TX/RX control and can be enable via the MULTI jumper block. See below for the RS-422/485 circuit diagram.

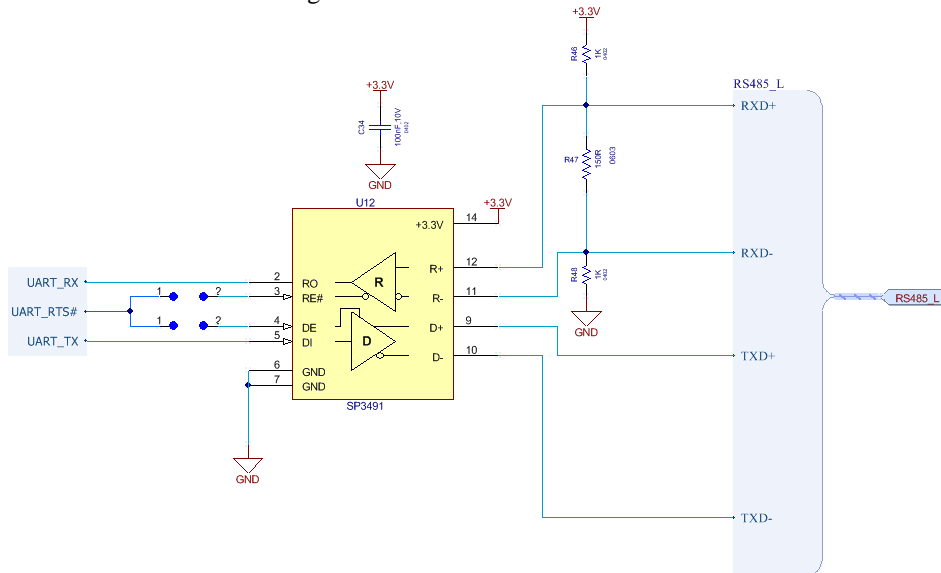

sample circuit shown (not exact circuit that is on-board)

GPIO and Console Serial Port

The COM Express Ultra-Lite carrier provides additional functionality of COM Express Type-6 specification.

GPIO / Serial Console Connector

Function	Console RS-232 / GPIO		
Locations	P9		
Type	2x10 2mm Header		
Pinout	Header Pin	Signal	DB9 Pin
	1	GPIO Input 0	1
	2	GPIO Output 3	6
	3	GPIO Input 1	2
	4	GPIO Output 2	7
	5	GPIO Input 2	3
	6	GPIO Output 1	8
	7	GPIO Input 3	4
	8	GPIO Output 0	9
	9	GND	5
	10	-	
	11	-	1
	12	-	6
	13	RS-232 TX	2
	14	RS-232 RX	7
	15	-	3
	16	-	8
	17	-	4
	18	-	9
	19	GND	5
20	-		

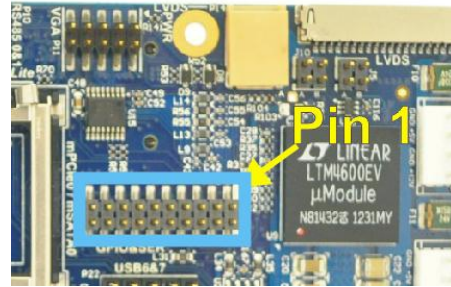

SD Card

The COM Express Ultra-Lite carrier provides a Micro SD Card Slot at P4. This Micro SD Card slot sources the SDIO interface from the COM Express modules GPIO pins.

**** Note this SD card slot will ONLY operate if the COM Express module provides the SDIO interface over the GPIO pins. See below for the SDIO / GPIO mapping ****

Also ensure **MULTI-JUMPER position “B”** is installed to select the SDIO interface.

Micro SD Card Connector

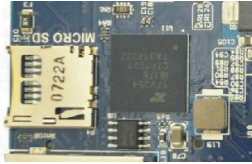
Function	Micro SD Card Slot			
Locations	P4 Part Number: 502570-0893			
Type	Micro SD Card Socket			
Pinout	Pin	SDIO Signal	COM Express GPIO Mapping	
	1	SD_D2	GPI2	
	2	SD_D3	GPI3	
	3	SD_CMD	GPO1	
	4	SD_VCC (+3.3V)	-	
	5	SD_CLK	GPO0	
	6	GND	-	
	7	SD_D0	GPI0	
	8	SD_D1	GPI1	
	9	GND	-	
10	SD_CD#	GP03		

Multifunction Jumper Block

The COM Express Type-6 Ultra-Lite Carrier has a multi-function jumper that provides control for various interfaces and features. The “MULTI” jumper is located at P23.

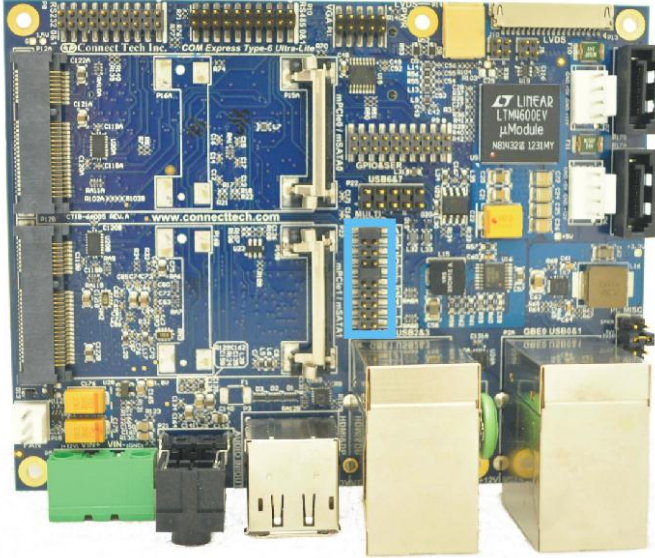

Below are the full details of the MULTI jumper block functionality.

Position	Description	JUMPER IN	JUMPER OFF
A	USB Port-7 Client/Host	Port-7 USB Host enabled. Power connected	Port-7 USB Client enabled. Power Disconnected
B	SD Card / GPIO Mux	SD Card Functionality is enabled	GPIO Functionality is enabled
C	mSATA / miniPCIe Slot-0 Selection	miniPCIe enabled	mSATA enabled
D	mSATA / miniPCIe Slot-1 Selection	miniPCIe enabled	mSATA enabled
E	PCIe UART EEPROM	Enable PCIe UART EEPROM	Disable PCIe UART EEPROM
F	PCIe UART - TRI State Enable	Enable TRI-State control for PCIe UART	Disable TRI-State control for PCIe UART
G	PCIe UART - 485 Port 0 - RTS-TX Control	Enable RS-485 Port-0 RTS-TX Control	Disable RS-485 Port-0 RTS-TX Control
H	PCIe UART - 485 Port 0 - RTS-RX Control	Enable RS-485 Port-0 RTS-RX Control	Disable RS-485 Port-0 RTS-RX Control
I	PCIe UART - 485 Port 1 - RTS-TX Control	Enable RS-485 Port-1 RTS-TX Control	Disable RS-485 Port-1 RTS-TX Control
J	PCIe UART - 485 Port 1 - RTS-RX Control	Enable RS-485 Port-1 RTS-RX Control	Disable RS-485 Port-1 RTS-RX Control

Note: Highlighted cell are the recommended default settings

Miscellaneous Control Header

This misc header can be used to connect power button, reset button, PC speaker, I2C device and monitor other power rails. Aswell it provides the option of jumpering the +5V rail to the +5VSB rail which may be needed by some modules.

Function	Miscellaneous Control Header			
Location	P23			
Type	2x10 0.1"			
Pinout	Pin	Description	Pin	Description
	1	+5V	2	Speaker
	3	+5V	4	+5VSB
	5	Ext CMOS Bat	6	GND
	7	System Reset	8	GND
	9	Power Button	10	GND
	11	Batlow#	12	GND
	13	Sus_S3#	14	GND
	15	I2C.CLK	16	GND
	17	I2C.DAT	18	GND
	19	+5V	20	GND



Typical Hardware Installation for +12V power input

1. Ensure all external system power supplies are off.
2. Install the COM Express module into P1. Be sure to follow the manufacturer's direction for proper heatsink/heatspreader installation and any other cooling instructions from the manufacturer.
3. Install the necessary cables for the application. At a minimum, this would include:
 - a) +12V Power cable to the input power connector.
 - b) Connect a video display cable VGA, HDMI, DisplayPort or LVDS.
 - c) Keyboard and mouse via USB
 - d) SATA Power and Signal to SATA HDD

For the relevant cables, see the Cables & Interconnect section of this manual

4. Connect the power cable to power supply
5. Switch on the power supply. DO NOT power up your COM Express system by plugging in live power.

Current Consumption Details

Below are the maximum ratings of the carrier.

Maximums	Amps	Watts
Theoretical absolute maximum total draw of all functionality on the carrier board (this value excludes current draw from module)	4.00 A	48 W
Safety Protected Maximum Current Draw Rating for Module and Carrier (from in-line fuse)	10.00 A	120 W

Below are some examples of actual measurements taken with the COM Express Ultra-Lite Carrier running in various test setups. Some values will change depending on what COM Express module is installed, please refer to the module manufactures manual for full details on the current consumption of the particular module you are using.

Actual Measurements	Amps	Watts
Carrier standalone no module installed, powered ON, with no loads	0.16 A	1.92 W
Module Installed ^[1] , single DDI video output, USB keyboard with system sitting in BIOS	1.29 A	15.48 W
Module Installed ^[1] , single DDI video output, USB keyboard, booted Linux running CPU stress test	2.60 A	31.20 W
Module Installed ^[1] , dual DDI video output, 4 x USB 3.0 devices installed, 2 x USB2.0 devices installed, mSATA installed, miniPCIe installed, audio in/out running, dual GBE running and CPU stress test	3.10 A	37.2 W

Note [1] : COM Express Type-6 Module used for measurements - Intel Core i5 Ivy Bridge 2700MHz Quad- Core Processor with QM77 chipset.

Mechanical Details

A complete 3D STEP Model file of carrier board can be downloaded here:

http://www.connecttech.com/ftp/3d_models/CCG008_3D_MODEL.zip

2D Mechanical Dimensioned Drawing (Top and Bottom Views) - All dimension are in (mm)

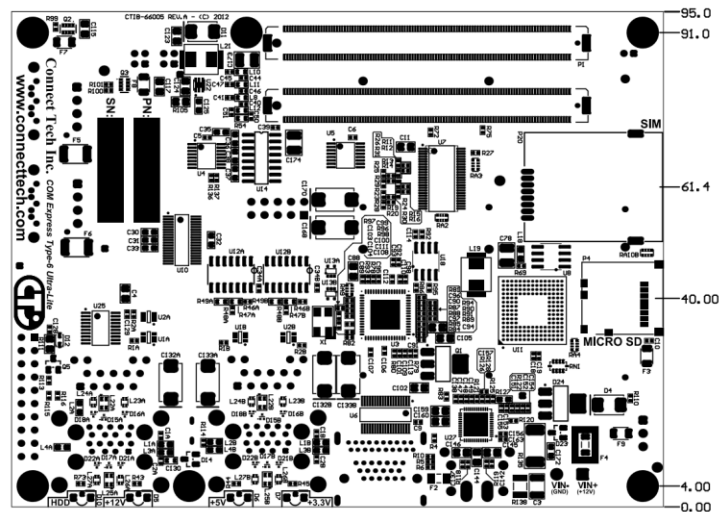
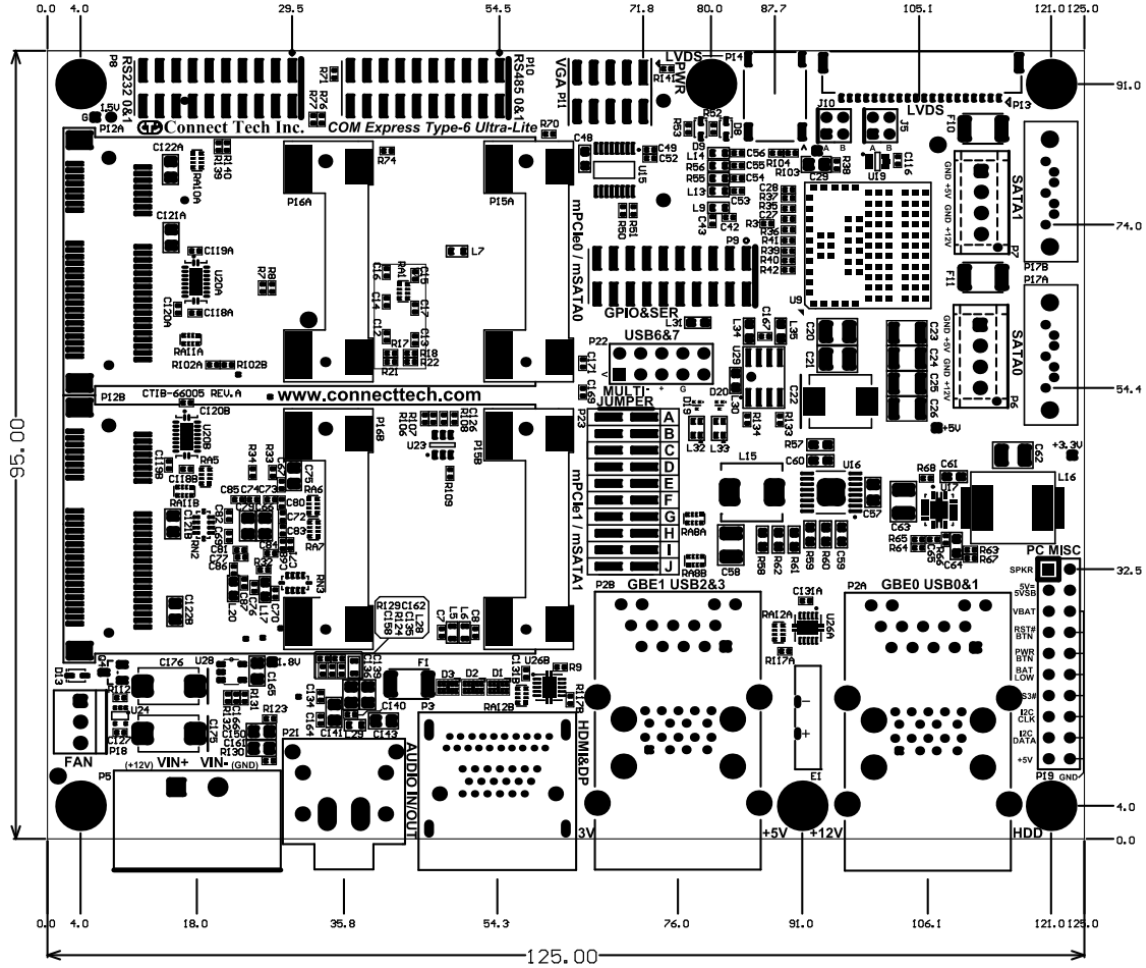

Cables & Interconnect

The following table summarizes the COM Express carrier's headers and lists the matching cables included with the optional cable kit CKG009.

PCB Connector	Cable Part Number	Description	PCB End	Interface End
2x10 2mm at P8, P9 and P10	CBG073	2 x Serial Cable (Also used for GPIO)	2x10 2mm header	2 x DB9 Male
4 Pin 0.1" Pitch Header at P6, P7, P17A, P17B	CBG090	SATA Power and Signal	SATA Power and Signal	SATA Power and Signal
2x5 2mm at P26	CBG070	VGA Cable	2x5 2mm	HDB15 Female

Cable drawings are available upon request. Send an email request to: support@connecttech.com

Appendix A – COM Express Signal/Pinout Connection Details

The following table summarizes the COM Express Type-6 Ultra-Lite’s COM Express signal/pinout utilization. From this table you will be able to see which COM Express signals have been used and where they are connected to on the carrier. As well No Connection pins are noted as “NC”, pull-ups as “PU” and pull-downs as “PD”.

COM Express Signal	COM Express Pin	CCG008 Connection
TYPE10#	A97	NC
TYPE0#	C54	NC
TYPE1#	C57	NC
TYPE2#	D57	NC
GPIO	A54	GPIO Ser Connector (P9)
GPI1	A63	GPIO Ser Connector (P9)
GPI2	A67	GPIO Ser Connector (P9)
GPI3	A85	GPIO Ser Connector (P9)
GPO0	A93	GPIO Ser Connector (P9)
GPO1	B54	GPIO Ser Connector (P9)
GPO2	B57	GPIO Ser Connector (P9)
GPO3	B63	GPIO Ser Connector (P9)
LPC_SERIRQ	A50	NC
LPC_FRAME#	B3	NC
LPC_AD0	B4	NC
LPC_AD1	B5	NC
LPC_AD2	B6	NC
LPC_AD3	B7	NC
LPC_DRQ0#	B8	PU
LPC_DRQ1#	B9	PU
LPC_CLK	B10	NC
THRMTRIP#	A35	NC
SMB_CK	B13	System Header
SMB_DAT	B14	System Header
SMB_ALERT#	B15	System Header
I2C_CK	B33	System Header
I2C_DAT	B34	System Header
THRM#	B35	PU
SUS_S3#	A15	System Header
SUS_S4#	A18	NC
SUS_S5#	A24	NC
LID#	A103	NC
PWRBTN#	B12	System Header
SUS_STAT#	B18	NC
PWR_OK	B24	System Header

SYS_RESET#	B49	System Header
CB_RESET#	B50	Carrier Board Internal Circuitry
SLEEP#	B103	NC
BATLOW#	A27	System Header
WAKE0#	B66	NC
WAKE1#	B67	NC
VGA_RED	B89	VGA Video
VGA_GRN	B91	VGA Video
VGA_BLU	B92	VGA Video
VGA_HSYNC	B93	VGA Video
VGA_VSYNC	B94	VGA Video
VGA_I2C_CK	B95	VGA Video
VGA_I2C_DAT	B96	VGA Video
AC/HDA_SYNC	A29	HD Audio
AC/HDA_RST#	A30	HD Audio
AC/HDA_BITCLK	A32	HD Audio
AC/HDA_SDOOUT	A33	HD Audio
AC/HDA_SDIN2	B28	PD
AC/HDA_SDIN1	B29	PD
AC/HDA_SDINO	B30	HD Audio
USB6-	A36	USB2.0 Port 6
USB6+	A37	USB2.0 Port 6
USB_6_7_OC#	A38	USB2.0 Port 6
USB4-	A39	miniPCIe Slot-0
USB4+	A40	miniPCIe Slot-0
USB2-	A42	USB3.0 Port-2
USB2+	A43	USB3.0 Port-2
USB_2_3_OC#	A44	USB3.0 Port-2/3
USB0-	A45	USB3.0 Port-0
USB0+	A46	USB3.0 Port-0
USB7-	B36	USB2.0 Port 7
USB7+	B37	USB2.0 Port 7
USB_4_5_OC#	B38	USB2.0 Port 7
USB5-	B39	miniPCIe Slot-1
USB5+	B40	miniPCIe Slot-1
USB3-	B42	USB3.0 Port-3
USB3+	B43	USB3.0 Port-3
USB_0_1_OC#	B44	USB3.0 Port-0/1
USB1-	B45	USB3.0 Port-1
USB1+	B46	USB3.0 Port-1
USB_SSTX0+	D4	USB3.0 Port-0

USB_SSTX0-	D3	USB3.0 Port-0
USB_SSRX0+	C4	USB3.0 Port-0
USB_SSRX0-	C3	USB3.0 Port-0
USB_SSTX1+	D7	USB3.0 Port-1
USB_SSTX1-	D6	USB3.0 Port-1
USB_SSRX1+	C7	USB3.0 Port-1
USB_SSRX1-	C6	USB3.0 Port-1
USB_SSTX2+	D10	USB3.0 Port-2
USB_SSTX2-	D9	USB3.0 Port-2
USB_SSRX2+	C10	USB3.0 Port-2
USB_SSRX2-	C9	USB3.0 Port-2
USB_SSTX3+	D13	USB3.0 Port-3
USB_SSTX3-	D12	USB3.0 Port-3
USB_SSRX3+	C13	USB3.0 Port-3
USB_SSRX3-	C12	USB3.0 Port-3
GND	D2	GND
GND	C2	GND
GND	D5	GND
GND	C5	GND
GND	D8	GND
GND	C8	GND
GND	D14	GND
GND	C14	GND
GBE0_MDI3-	A2	GBE Port 0
GBE0_MDI3+	A3	GBE Port 0
GBE0_LINK100#	A4	GBE Port 0
GBE0_LINK1000#	A5	GBE Port 0
GBE0_MDI2-	A6	GBE Port 0
GBE0_MDI2+	A7	GBE Port 0
GBE0_LINK#	A8	GBE Port 0
GBE0_MDI1-	A9	GBE Port 0
GBE0_MDI1+	A10	GBE Port 0
GBE0_MDI0-	A12	GBE Port 0
GBE0_MDI0+	A13	GBE Port 0
GBE0_CTREF	A14	GBE Port 0
GBE0_ACT#	B2	GBE Port 0
EXCD0_PERST#	A48	NC
EXCD0_CPPE#	A49	NC
EXCD1_PERST#	B47	NC
EXCD1_CPPE#	B48	NC
GND (FIXED)	A1	GND

GND (FIXED)	A11	GND
GND (FIXED)	A21	GND
GND (FIXED)	A31	GND
GND (FIXED)	A41	GND
VCC_RTC	A47	RTC Battery
GND (FIXED)	A51	GND
GND (FIXED)	A60	GND
GND (FIXED)	A70	GND
GND (FIXED)	A80	GND
GND (FIXED)	A90	GND
GND (FIXED)	A100	GND
VCC_12V	A104	Input Power +VIN (P5)
VCC_12V	A105	Input Power +VIN (P5)
VCC_12V	A106	Input Power +VIN (P5)
VCC_12V	A107	Input Power +VIN (P5)
VCC_12V	A108	Input Power +VIN (P5)
VCC_12V	A109	Input Power +VIN (P5)
GND (FIXED)	A110	GND
GND (FIXED)	B1	GND
GND (FIXED)	B11	GND
GND (FIXED)	B21	GND
GND (FIXED)	B31	GND
GND (FIXED)	B41	GND
GND (FIXED)	B51	GND
GND (FIXED)	B60	GND
GND (FIXED)	B70	GND
GND (FIXED)	B80	GND
VCC_5V_SBY	B84	System Header (Can be Jumpered to +5V)
VCC_5V_SBY	B85	System Header (Can be Jumpered to +5V)
VCC_5V_SBY	B86	System Header (Can be Jumpered to +5V)
VCC_5V_SBY	B87	System Header (Can be Jumpered to +5V)
GND (FIXED)	B90	GND
RSVD	B98	NC
RSVD	B99	NC
GND (FIXED)	B100	GND
VCC_12V	B104	Input Power +VIN (P5)
VCC_12V	B105	Input Power +VIN (P5)
VCC_12V	B106	Input Power +VIN (P5)
VCC_12V	B107	Input Power +VIN (P5)
VCC_12V	B108	Input Power +VIN (P5)
VCC_12V	B109	Input Power +VIN (P5)

GND (FIXED)	B110	GND
RSVD	A86	NC
RSVD	A87	NC
GND (FIXED)	C1	GND
GND (FIXED)	C11	GND
GND (FIXED)	C21	GND
GND (FIXED)	C31	GND
GND (FIXED)	C41	GND
GND (FIXED)	C51	GND
GND (FIXED)	C60	GND
GND (FIXED)	C70	GND
GND (FIXED)	C80	GND
GND (FIXED)	C90	GND
GND (FIXED)	C100	GND
GND (FIXED)	C110	GND
GND (FIXED)	D1	GND
GND (FIXED)	D11	GND
GND (FIXED)	D21	GND
GND (FIXED)	D31	GND
GND (FIXED)	D41	GND
GND (FIXED)	D51	GND
GND (FIXED)	D60	GND
GND (FIXED)	D70	GND
GND (FIXED)	D80	GND
GND (FIXED)	D90	GND
GND (FIXED)	D100	GND
GND (FIXED)	D110	GND
RSVD	C63	NC
RSVD	C64	NC
RSVD	C83	NC
RSVD	C97	NC
RSVD	D63	NC
RSVD	D64	NC
RSVD	D83	NC
VCC_12V	C104	Input Power +VIN (P5)
VCC_12V	C105	Input Power +VIN (P5)
VCC_12V	C106	Input Power +VIN (P5)
VCC_12V	C107	Input Power +VIN (P5)
VCC_12V	C108	Input Power +VIN (P5)
VCC_12V	C109	Input Power +VIN (P5)
VCC_12V	D104	Input Power +VIN (P5)

VCC_12V	D105	Input Power +VIN (P5)
VCC_12V	D106	Input Power +VIN (P5)
VCC_12V	D107	Input Power +VIN (P5)
VCC_12V	D108	Input Power +VIN (P5)
VCC_12V	D109	Input Power +VIN (P5)
RSVD	D97	NC
RSVD	C17	NC
RSVD	C18	NC
RSVD	D17	NC
RSVD	D18	NC
RSVD	D24	NC
RSVD	D25	NC
RSVD	C27	NC
RSVD	C28	NC
RSVD	D28	NC
RSVD	C35	NC
RSVD	D35	NC
RSVD	D38	NC
RSVD	C45	NC
RSVD	D45	NC
RSVD	C48	NC
RSVD	D48	NC
RSVD	C67	NC
RSVD	C77	NC
RSVD	D77	NC
PEG_RX0+	C52	NC
PEG_RX0-	C53	NC
PEG_RX1+	C55	NC
PEG_RX1-	C56	NC
PEG_RX2+	C58	NC
PEG_RX2-	C59	NC
PEG_RX3+	C61	NC
PEG_RX3-	C62	NC
PEG_RX4+	C65	NC
PEG_RX4-	C66	NC
PEG_RX5+	C68	NC
PEG_RX5-	C69	NC
PEG_RX6+	C71	NC
PEG_RX6-	C72	NC
GND	C73	GND
PEG_RX7+	C74	NC

PEG_RX7-	C75	NC
GND	C76	GND
PEG_RX8+	C78	NC
PEG_RX8-	C79	NC
PEG_RX9+	C81	NC
PEG_RX9-	C82	NC
GND	C84	GND
PEG_RX10+	C85	NC
PEG_RX10-	C86	NC
GND	C87	NC
PEG_RX11+	C88	NC
PEG_RX11-	C89	NC
PEG_RX12+	C91	NC
PEG_RX12-	C92	NC
GND	C93	GND
PEG_RX13+	C94	NC
PEG_RX13-	C95	NC
GND	C96	GND
PEG_RX14+	C98	NC
PEG_RX14-	C99	NC
PEG_RX15+	C101	NC
PEG_RX15-	C102	NC
GND	C103	GND
PEG_TX0+	D52	NC
PEG_TX0-	D53	NC
PEG_LANE_RV#	D54	NC
PEG_TX1+	D55	NC
PEG_TX1-	D56	NC
PEG_TX2+	D58	NC
PEG_TX2-	D59	NC
PEG_TX3+	D61	NC
PEG_TX3-	D62	NC
PEG_TX4+	D65	NC
PEG_TX4-	D66	NC
GND	D67	GND
PEG_TX5+	D68	NC
PEG_TX5-	D69	NC
PEG_TX6+	D71	NC
PEG_TX6-	D72	NC
GND	D73	GND
PEG_TX7+	D74	NC

PEG_TX7-	D75	NC
GND	D76	GND
PEG_TX8+	D78	NC
PEG_TX8-	D79	NC
PEG_TX9+	D81	NC
PEG_TX9-	D82	NC
GND	D84	GND
PEG_TX10+	D85	NC
PEG_TX10-	D86	NC
GND	D87	GND
PEG_TX11+	D88	NC
PEG_TX11-	D89	NC
PEG_TX12+	D91	NC
PEG_TX12-	D92	NC
GND	D93	GND
PEG_TX13+	D94	NC
PEG_TX13-	D95	NC
GND	D96	GND
PEG_TX14+	D98	NC
PEG_TX14-	D99	NC
PEG_TX15+	D101	NC
PEG_TX15-	D102	NC
GND	D103	GND
PCIE_TX5+	A52	NC
PCIE_TX5-	A53	NC
PCIE_TX4+	A55	NC
PCIE_TX4-	A56	NC
PCIE_TX3+	A58	GBE PHY Controller
PCIE_TX3-	A59	GBE PHY Controller
PCIE_TX2+	A61	miniPCle Slot-1
PCIE_TX2-	A62	miniPCle Slot-1
PCIE_TX1+	A64	miniPCle Slot-0
PCIE_TX1-	A65	miniPCle Slot-0
PCIE_TX0+	A68	4-Port PCIe UART
PCIE_TX0-	A69	4-Port PCIe UART
PCIE_CLK_REF+	A88	Main Carrier PCIe Clock
PCIE_CLK_REF-	A89	Main Carrier PCIe Clock
PCIE_RX5+	B52	NC
PCIE_RX5-	B53	NC
PCIE_RX4+	B55	NC
PCIE_RX4-	B56	NC

PCIE_RX3+	B58	GBE PHY Controller
PCIE_RX3-	B59	GBE PHY Controller
PCIE_RX2+	B61	miniPCle Slot-1
PCIE_RX2-	B62	miniPCle Slot-1
PCIE_RX1+	B64	miniPCle Slot-0
PCIE_RX1-	B65	miniPCle Slot-0
PCIE_RX0+	B68	4-Port PCle UART
PCIE_RX0-	B69	4-Port PCle UART
GND	A57	GND
GND	A66	GND
PCIE_TX6+	D19	NC
PCIE_TX6-	D20	NC
PCIE_RX6+	C19	NC
PCIE_RX6-	C20	NC
PCIE_TX7+	D22	NC
PCIE_TX7-	D23	NC
PCIE_RX7+	C22	NC
PCIE_RX7-	C23	NC
SATA0_TX+	A16	SATA-0 (P17A)
SATA0_TX-	A17	SATA-0 (P17A)
SATA0_RX+	A19	SATA-0 (P17A)
SATA0_RX-	A20	SATA-0 (P17A)
SATA2_TX+	A22	mini-PCle/mSATA Slot-0
SATA2_TX-	A23	mini-PCle/mSATA Slot-0
SATA2_RX+	A25	mini-PCle/mSATA Slot-0
SATA2_RX-	A26	mini-PCle/mSATA Slot-0
SATA_ACT#	A28	LED
SATA1_TX+	B16	SATA-1 (P17B)
SATA1_TX-	B17	SATA-1 (P17B)
SATA1_RX+	B19	SATA-1 (P17B)
SATA1_RX-	B20	SATA-1 (P17B)
SATA3_TX+	B22	miniPCle/mSATA Slot-1
SATA3_TX-	B23	miniPCle/mSATA Slot-1
SATA3_RX+	B25	miniPCle/mSATA Slot-1
SATA3_RX-	B26	miniPCle/mSATA Slot-1
LVDS_A0+	A71	LVDS Video (P13)
LVDS_A0-	A72	LVDS Video (P13)
LVDS_A1+	A73	LVDS Video (P13)
LVDS_A1-	A74	LVDS Video (P13)
LVDS_A2+	A75	LVDS Video (P13)
LVDS_A2-	A76	LVDS Video (P13)

LVDS_VDD_EN	A77	LVDS Video (P13)
LVDS_A3+	A78	NC
LVDS_A3-	A79	NC
LVDS_A_CK+	A81	LVDS Video (P13)
LVDS_A_CK-	A82	LVDS Video (P13)
LVDS_I2C_CK	A83	NC
LVDS_I2C_DAT	A84	NC
LVDS_B0+	B71	NC
LVDS_B0-	B72	NC
LVDS_B1+	B73	NC
LVDS_B1-	B74	NC
LVDS_B2+	B75	NC
LVDS_B2-	B76	NC
LVDS_B3+	B77	NC
LVDS_B3-	B78	NC
LVDS_BKLT_EN	B79	LVDS Video (P13)
LVDS_B_CK+	B81	NC
LVDS_B_CK-	B82	NC
LVDS_BKLT_CTRL	B83	LVDS Video (P13)
BIOS_DIS0#	A34	PU
SPI_POWER	A91	NC
SPI_MISO	A92	NC
SPI_CLK	A94	NC
SPI_MOSI	A95	NC
BIOS_DIS1#	B88	PU
SPI_CS#	B97	NC
TPM_PP	A96	NC
WDT	B27	NC
SPKR	B32	System Header
FAN_PWMOUT	B101	NC
FAN_TACHOIN	B102	Fan Connector
SER0_TX	A98	GPIO Ser Connector (P9)
SER0_RX	A99	GPIO Ser Connector (P9)
SER1_TX	A101	NC
SER1_RX	A102	PU
DDI1_PAIR0+	D26	HDMI Video (P3)
DDI1_PAIR0-	D27	HDMI Video (P3)
DDI1_PAIR1+	D29	HDMI Video (P3)
DDI1_PAIR1-	D30	HDMI Video (P3)
DDI1_PAIR2+	D32	HDMI Video (P3)
DDI1_PAIR2-	D33	HDMI Video (P3)

DDI1_PAIR3+	D36	HDMI Video (P3)
DDI1_PAIR3-	D37	HDMI Video (P3)
DDI1_PAIR4+	C25	NC
DDI1_PAIR4-	C26	NC
DDI1_PAIR5+	C29	NC
DDI1_PAIR5-	C30	NC
DDI1_HPD	C24	HDMI Video (P3)
DDI1_CTRLCLK_AUX+	D15	HDMI Video (P3)
DDI1_CTRLDATA_AUX-	D16	HDMI Video (P3)
DDI1_DDC_AUX_SEL	D34	PU
DDI2_PAIR0+	D39	DisplayPort Video (P3)
DDI2_PAIR0-	D40	DisplayPort Video (P3)
DDI2_PAIR1+	D42	DisplayPort Video (P3)
DDI2_PAIR1-	D43	DisplayPort Video (P3)
DDI2_PAIR2+	D46	DisplayPort Video (P3)
DDI2_PAIR2-	D47	DisplayPort Video (P3)
DDI2_PAIR3+	D49	DisplayPort Video (P3)
DDI2_PAIR3-	D50	DisplayPort Video (P3)
DDI2_HPD	D44	DisplayPort Video (P3)
DDI2_CTRLCLK_AUX+	C32	DisplayPort Video (P3)
DDI2_CTRLDATA_AUX-	C33	DisplayPort Video (P3)
DDI2_DDC_AUX_SEL	C34	DisplayPort Video (P3)
DDI3_PAIR0+	C39	NC
DDI3_PAIR0-	C40	NC
DDI3_PAIR1+	C42	NC
DDI3_PAIR1-	C43	NC
DDI3_PAIR2+	C46	NC
DDI3_PAIR2-	C47	NC
DDI3_PAIR3+	C49	NC
DDI3_PAIR3-	C50	NC
DDI3_HPD	C44	NC
DDI3_CTRLCLK_AUX+	C36	NC
DDI3_CTRLDATA_AUX-	C37	NC
DDI3_DDC_AUX_SEL	C38	NC
DDI1_PAIR6+	C15	NC
DDI1_PAIR6-	C16	NC