



**Connect Tech Inc.**  
*Industrial Strength Communications*

---

# Blue Heat/Net Sync

## User Manual

Ethernet-to-Serial Synchronous Communications



Connect Tech Inc  
42 Arrow Road  
Guelph, Ontario  
N1K 1S6

**Tel:** 519-836-1291

**Toll:** 800-426-8979 (North America only)

**Fax:** 519-836-4878

**Email:** [sales@connecttech.com](mailto:sales@connecttech.com)

[support@connecttech.com](mailto:support@connecttech.com)

**Web:** [www.connecttech.com](http://www.connecttech.com)

## Limited Lifetime Warranty

Connect Tech Inc. provides a Lifetime Warranty for all Connect Tech Inc. products. Should this product, in Connect Tech Inc.'s opinion, fail to be in good working order during the warranty period, Connect Tech Inc. will, at its option, repair or replace this product at no charge, provided that the product has not been subjected to abuse, misuse, accident, disaster or non Connect Tech Inc. authorized modification or repair.

You may obtain warranty service by delivering this product to an authorized Connect Tech Inc. business partner or to Connect Tech Inc. along with proof of purchase. Product returned to Connect Tech Inc. must be pre-authorized by Connect Tech Inc. with an RMA (Return Material Authorization) number marked on the outside of the package and sent prepaid, insured and packaged for safe shipment. Connect Tech Inc. will return this product by prepaid shipment service.

The Connect Tech Inc. lifetime warranty is defined as the serviceable life of the product. This is defined as the period during which all components are available. Should the product prove to be irreparable, Connect Tech Inc. reserves the right to substitute an equivalent product if available or to retract lifetime warranty if no replacement is available.

The above warranty is the only warranty authorized by Connect Tech Inc. Under no circumstances will Connect Tech Inc. be liable in any way for any damages, including any lost profits, lost savings or other incidental or consequential damages arising out of the use of, or inability to use, such product.

## Copyright Notice

The information contained in this document is subject to change without notice. Connect Tech Inc. shall not be liable for errors contained herein or for incidental consequential damages in connection with the furnishing, performance, or use of this material. This document contains proprietary information that is protected by copyright. All rights are reserved. No part of this document may be photocopied, reproduced, or translated to another language without the prior written consent of Connect Tech, Inc.

Copyright © 2008 by Connect Tech Inc.

## Trademark Acknowledgment

Connect Tech Inc. acknowledges all trademarks, registered trademarks and/or copyrights referred to in this document as the property of their respective owners.

Not listing all possible trademarks or copyright acknowledgments does not constitute a lack of acknowledgment to the rightful owners of the trademarks and copyrights mentioned in this document.

## Customer Support Overview

If you experience difficulties after reading the manual and/or using the product, contact the Connect Tech reseller from which you purchased the product. In most cases the reseller can help you with product installation and difficulties.

In the event that the reseller is unable to resolve your problem, our highly qualified support staff can assist you. Our support section is available 24 hours a day, seven days a week on our website at:

[www.connecttech.com/sub/support/support.asp](http://www.connecttech.com/sub/support/support.asp). See the contact information section below for more information on how to contact us directly. Our technical support is always free.

## Contact Information

We offer three ways for you to contact us:

### Telephone/Facsimile

Technical Support representatives are ready to answer your call Monday through Friday, from 8:30 a.m. to 5:00 p.m. Eastern Standard Time. Our numbers for calls are:

Telephone: 800-426-8979 (North America only)

Telephone: 519-836-1291 (Live assistance available 8:30 a.m. to 5:00 p.m. EST, Monday to Friday)

Facsimile: 519-836-4878 (online 24 hours)

### Email/Internet

You may contact us through the Internet. Our email and URL addresses are:

[sales@connecttech.com](mailto:sales@connecttech.com)

[support@connecttech.com](mailto:support@connecttech.com)

[www.connecttech.com](http://www.connecttech.com)

### Mail/Courier

You may contact us by letter and our mailing address for correspondence is:

Connect Tech Inc.  
Technical Support  
42 Arrow Road  
Guelph, Ontario  
Canada N1K 1S6

#### **Note:**

Please go to the [Download Zone](#) or the [Knowledge Database](#) in the [Support Center](#) on the Connect Tech website for product manuals, installation guides, device driver software and technical tips.

Submit your technical support questions to our customer support engineers via the [Support Center](#) on the Connect Tech website.

## Certification Statements




**Preliminary: Testing is still pending.**

### Class A Computing Device

Connect Tech Inc. declares that the product(s) covered by the contents of this manual have been tested and found compliant with the below listed standards as required by the Electromagnetic Compatibility (EMC) Directive for General Immunity Compliance.

EN 55022	Conducted and Radiated emissions		
CISPR 22	Class A		
EN 55024	Immunity to Disturbances		
EN 61000-4-2	EN 61000-4-4	EN 61000-4-6	EN 61000-3-2 Exempt
EN 61000-4-3	EN 61000-4-5	EN 61000-4-11	EN 61000-3-3 Pass

The above satisfy the requirements of:

USA:	FCC – CFR47, Part 15, part 2	
Canada:	ICES-003	
Europe	EMC Directive	
Japan:	VCCI	
Australia/New Zealand:	AS/NZS	

**Preliminary: Testing is still pending.**

## Table of Contents

Limited Lifetime Warranty .....	2
Copyright Notice.....	2
Trademark Acknowledgment.....	2
Customer Support Overview.....	3
Contact Information.....	3
Certification Statements.....	4
Table of Contents.....	5
List of Figures.....	8
List of Tables.....	9
Introduction.....	10
<i>Features</i> .....	10
<i>Understanding Virtual COM Ports</i> .....	11
Blue Heat/Net Sync Installation Overview .....	11
Hardware Installation.....	12
<i>Connecting the Blue Heat/Net Sync to Your Network:</i> .....	12
<i>Ethernet LEDs</i> .....	12
<i>Serial Port LEDs</i> .....	13
<i>Connecting Serial Devices</i> .....	13
<i>V.28 Connections:</i> .....	13
Basic Async (V.28) RS-232 Null Modem Connection.....	13
Basic Sync (V.28) RS-232 Connection (Provides Clock).....	13
Basic Sync (V.28) RS-232 Connection (Receives Clock).....	13
<i>RS-422/V.11 Connections</i> .....	14
<i>Blue Heat/Net Synchronous Clocking</i> .....	14
<i>Loopback Connectors</i> .....	15
<i>Connecting Power</i> .....	16
DC Power Connector.....	16
Phoenix Locking Screw Terminal Connector.....	16
<i>Activating the Special Operations Mode and Default Settings</i> .....	16
<i>Using the Reset Button to Activate the Special Operations Mode</i> .....	16
<i>Selecting a Special Operation</i> .....	17
<i>Power On Diagnostics:</i> .....	18
<i>LED Error Codes</i> .....	18
<i>SCM Cabling requirements</i> .....	21
<i>SCM: Serial Configuration Manager</i> .....	21
<i>Setting a Static or Dynamic IP Address</i> .....	21
<i>Set the IP Address Using the Web Configuration Manager</i> .....	22
<i>Set the IP Address Using the Serial Configuration Manager</i> .....	22
Blue Heat/Net Sync Configuration .....	23
<i>CDS (Configuration Data Space)</i> .....	24
<i>Description</i> .....	24
<i>Access to CDS Parameters</i> .....	24
<i>SCM (Serial Configuration Manager)</i> .....	25
<i>Description</i> .....	25
<i>Getting Access to the SCM</i> .....	25
<i>SCM Command Reference</i> .....	25
Brief Command List.....	25
Command Details .....	26
boot.....	26
cfg .....	26
exit .....	27
help .....	27
info .....	27
net.....	27
save .....	29
update .....	29
<i>WCM (Web Configuration Manager)</i> .....	31
<i>Signing In to the Web Configuration Manager</i> .....	31
<i>Configure Advanced Serial Settings</i> .....	33

Configure Blue Heat/Net Sync Settings .....	33
Configure Firmware .....	35
Restore Defaults .....	35
Saving To Flash .....	36
<i>Monitoring Your Blue Heat/Net</i> .....	37
Monitor Serial Port Traffic .....	37
Monitor Network Traffic .....	38
Monitor TCP/IP Statistics .....	38
My Blue Heat/Net Sync .....	38
Software Installation for Windows .....	40
<i>Installing the Blue Heat/Net Sync Configuration Manager</i> .....	40
<i>Running the Configuration Manager</i> .....	44
<i>Device Installation</i> .....	44
<i>Configure Default Blue Heat/Net Sync</i> .....	45
<i>Add New Blue Heat/Net Sync</i> .....	45
<i>Auto Discover Blue Heat/Net Sync</i> .....	46
<i>Configuring the Blue Heat/Net Sync</i> .....	47
<i>Port Mapping</i> .....	48
Express .....	48
Basic .....	50
Blue Heat/Net Sync Port: .....	50
Local COM Port: .....	51
Friendly Name: .....	51
Advanced .....	51
<i>Unmap Port(s):</i> .....	52
<i>Remapping Ports</i> .....	53
<i>Port Properties</i> .....	54
<i>Advanced Settings</i> .....	55
<i>Special Options</i> .....	55
<i>Line Interface modes</i> .....	56
<i>The following line interface modes can be selected:</i> .....	56
• RS-232 (V.28) .....	56
• V.35 .....	56
• EIA-530 .....	56
• EIA-530A .....	56
• RS-449 (V.36) .....	56
• X.21 (V.11) .....	56
<i>Options for EIA-530, EIA-530A, RS-449, X.21</i> .....	56
<i>Baud Rate Mapping</i> .....	56
<i>COM Port Number</i> .....	57
<i>Scan</i> .....	57
<i>Defaults Button</i> .....	57
<i>Export Settings</i> .....	57
<i>Import Settings</i> .....	57
<i>Replacing your Blue Heat/Net Sync:</i> .....	58
<i>Removing your Blue Heat/Net Sync:</i> .....	58
<i>Blue Heat/Net Sync Properties:</i> .....	58
<i>Driver Removal</i> .....	59
Software Installation for Linux .....	60
<i>Installing the Linux Host Driver</i> .....	60
<i>Linux Host Driver Setup Using Auto Discovery</i> .....	60
Firmware Upgrades .....	61
<i>Upgrade using WCM (Web Configuration Manager)</i> .....	61
<i>Upgrade using SCM (Serial Configuration Manager)</i> .....	61
Software Development .....	62
<i>Memory Map of IUSC and PLD Functions</i> .....	64
ColdFire (5272) Bus: .....	64
IUSC Access: .....	64
PLD Resource Access: .....	65
<i>PLD Memory Map Table</i> .....	65
<i>Port Settings, Clock Setup and General Settings</i> .....	73
<i>IUSC Clocking Logic:</i> .....	75
Appendix .....	76

<i>Blue Heat/Net Sync Specifications</i> .....	76
<i>Operating Environment</i> .....	76
<i>Communications</i> .....	76
<i>ESD Protection</i> .....	76
<i>Power</i> .....	76
<i>Connectors</i> .....	76
<i>Dimensions</i> .....	76
<i>Cable and Power Supply Options</i> .....	76
<i>Protocol Descriptions</i> .....	77
<i>Pinouts</i> .....	78
<i>DB-25 Female Pinouts</i> .....	78
<i>DB-9 Female Pinouts</i> .....	79
<i>Multi-drop Communications Using V.11 / RS422/RS485 Line Modes</i> .....	80
<i>Rack Mount Option:</i> .....	80
<i>Default Settings</i> .....	81
<i>Network Settings</i> .....	81
<i>Boot Settings</i> .....	81
<i>SCM Operation Settings</i> .....	81
<i>Common Configuration Setups</i> .....	82
<i>Static IP Setup</i> .....	82
Using SCM .....	82
Using WCM .....	82
<i>DHCP Setup</i> .....	83
Using SCM .....	83
<i>How the Blue Heat/Net Sync Boots Up</i> .....	83
<i>Bootup Sequence</i> .....	84
<i>Flowchart of Special Operations Mode using the reset button</i> .....	85
<i>Asynchronous Communications Tutorial</i> .....	85
<i>Serial Line Interface Tutorial</i> .....	86
<i>RS-232 Line Interface:</i> .....	86
<i>Differential Line Interfaces:</i> .....	86
<i>RS485/RS422/V.11 Details</i> .....	86
Basic 4-Wire, Full Duplex Communications:.....	87
Multi-drop 4-Wire, Full Duplex Communications: .....	88
Basic - Wire, Half Duplex Multi-drop Connection:.....	88
<i>Bus Contention on Differential Multi-drop Networks:</i> .....	89
<i>Termination Resistors in Differential Networks</i> .....	90
Termination Resistors in Differential Networks: .....	90

## List of Figures

Figure 1: LED Locations on Blue Heat/Net Sync.....	12
Figure 2: Basic V.28 Asynchronous Connections .....	13
Figure 3: Basic V.28 Synchronous Connections .....	13
Figure 4: Basic V.28 Synchronous Connections .....	13
Figure 5: Basic RS-422/V.11 Asynchronous Connections .....	14
Figure 6: Basic RS422/V.11 Synchronous Connections.....	14
Figure 7: Recommended Pinouts for V.28 (RS-232) Loopback Connector.....	15
Figure 8: Recommended Pinouts for a V.11 (RS422) Loopback Connector .....	15
Figure 9: DC Power Connector Illustration .....	16
Figure 10: Phoenix Locking Screw Terminal Power Connector Illustration.....	16
Figure 11: LED Error Code Example .....	18
Figure 12: Blue Heat/Net Sync Serial Cable Connection Diagram.....	21
Figure 13: Web Configuration Manager Sign In .....	31
Figure 14: Blue Heat/Net Sync Settings .....	32
Figure 15: Configuring Blue Heat/Net Sync Settings.....	34
Figure 16: Firmware Upgrades/Downloads.....	35
Figure 17: Restore Default Settings .....	36
Figure 18: Saving To Flash.....	37
Figure 19: Monitoring Serial Port Activity.....	37
Figure 20: Monitoring Network Traffic .....	38
Figure 21: Monitoring TCP/IP Statistics .....	38
Figure 22: My Blue Heat/Net Sync Hardware Details.....	39
Figure 23: My Blue Heat/Net Sync Software Details .....	39
Figure 24: Blue Heat/Net Sync Driver/Software Installation CD .....	40
Figure 25: Blue Heat/Net Sync Software Installation Screen .....	41
Figure 26: My Blue Heat/Net Sync Places Screen .....	44
Figure 27: Add or Auto Discover Blue Heat/Net Sync Menu Screen .....	45
Figure 28: Add Blue Heat/Net Sync Screen .....	45
Figure 29: Auto Discover Blue Heat/Net Sync Screen .....	46
Figure 30: Installed Blue Heat/Net Sync Screen .....	47
Figure 31: Map Port(s) Menu .....	48
Figure 32: Map Port(s) Express Method Screen.....	48
Figure 33: Found New Hardware Wizard.....	49
Figure 34: Configuration Manager Window after Successfully Mapping Ports.....	50
Figure 35: Basic Port Mapping Option.....	50
Figure 36: Advanced Port Mapping Interface .....	51
Figure 37: Port Action Menu .....	52
Figure 38: Unmap Port Window .....	53
Figure 39: Remap Port Window.....	53
Figure 40: Port Properties Window.....	54
Figure 41: Advanced Settings Window.....	55
Figure 42: Baud Rate Mapping Options .....	56
Figure 43: Replace Blue Heat/Net Sync Window .....	58
Figure 44: Blue Heat/Net Sync Properties.....	59
Figure 45: Remove Drivers Window .....	59
Figure 46: Bootup Sequence .....	84
Figure 47: Bootup Sequence via Reset Button .....	85
Figure 48: Typical Asynchronous Data Frame .....	86

## List of Tables

<i>Table 1: Available Special Operations</i>	18
<i>Table 2: LED Error Codes for Blue Heat/Net Sync</i>	19
<i>Table 3: Chip Selects</i>	62
<i>Table 4: Interrupts</i>	63
<i>Table 5: ColdFire MCF5272 GPIO</i>	63
<i>Table 6: Base Address Map</i>	63
<i>Table 7: DB-25 Female Pinouts</i>	78
<i>Table 8: DB-9 Female Pinouts</i>	79

## Introduction

Connect Tech's Blue Heat/Net Sync allows remote access to synchronous/asynchronous serial devices via an Ethernet LAN or the Internet. Blue Heat/Net Sync network-enables serial communication devices that are designed to be connected to serial ports so that the devices no longer need to be tied to a single computer.

The Blue Heat/Net Sync hardware is simple to install as it involves little more than plugging the unit into the appropriate locations and performing the configuration steps outlined in this manual.

Driver setup is made easy by Blue Heat/Net Sync's auto-detection feature. The software does the work of locating the units, while the Configuration Manager leads you through the rest of the installation.

Blue Heat/Net Sync's firmware is easily configured with a choice of methods: web browser, Telnet, or direct serial connection with a terminal and/or terminal software. Once the Blue Heat/Net Sync has been configured to your specifications, you will be able to remotely access your devices immediately.

## Features

- Four software selectable synchronous or asynchronous serial ports
- Software switchable; V.28, V.10, V.11, V.35, EIA-530, X.21 line modes
- Software switchable line modes and termination
- Supports NRZ, NRZB, NRZI-Mark, NRZI-Space, B-Phase-Space, B-Phase-Manchester, Differential Bi-Phase encoding
- Transmission rates up to 9.216 Mbps (synchronous), 230.4 Kbps (asynchronous). 10 Mbps communications possible with external clock.
- Bipolar clock input accepts sine/square wave signals up to 20 MHz +/- 10V.
- Includes synchronous protocols; SDLC, HDLC, MonoSync, BiSync, Transparent BiSync
- Software selectable internal and external clocking modes. External clocking is provided on TXC and RXC pins
- Supports IP, TCP, UDP, ARP, RARP, TFTP, DHCP, BOOTP, HTTP, PPP, Telnet and DNS
- Use of TCP/IP means communications can be routed to support WANs, as well as LANs. The Blue Heat/Net Sync does not need to be located at the same site as the controlling computer
- Point-to-Point Protocol (PPP) client and server
- Raw TCP client and server
- Several levels of security are built into the Blue Heat/Net Sync that can limit connections and help to ensure the privacy of data flow
- Memory: 8 MB flash, 16 MB SDRAM
- Includes an auto-MDIX 10Base-T, 100Base-TX LAN interface
- Network boot or booting from built-in flash memory
- Firmware upgrades are downloadable
- Customizable uClinux embedded operating system running on a ColdFire embedded processor. Free Software Development Kit available
- Configuration can be done via Web Browser, Telnet or direct serial connection
- Front mounted diagnostic LEDs
- 5-28 VDC power input using either DC barrel or Phoenix screw terminal connector
- Optional 5VDC power supply available
- 1U rack mount kit available

## Understanding Virtual COM Ports

In a typical serial port setup, the application communicates directly with the connected serial port hardware.

Virtual COM ports differ in that the application communicates with a network protocol layer that transfers the necessary information to and from the remote serial ports. The virtual ports appear as standard serial ports to the application, but in reality the data is translated into a series of Ethernet messages between the Blue Heat/Net Sync unit and the host computer. The serial port is not physically connected to the host computer, but this is transparent to the application trying to access it.

There are several advantages to using virtual COM ports, which include:

- **Distance** – The serial ports can be a great distance away from the host computer. They are not limited by the standard electrical characteristics of the RS-232 or RS-422 interface because the primary data transfer is being done via Ethernet. Depending on the set up, these serial ports can be at a different location and the Internet can act as the carrier of the serial port traffic.
- **Speed** – Short RS-232/422 cable lengths can be used with the primary distance relying on the network connection. The capacitance of long lengths of serial cable does not limit data speeds in these cases.
- **Cabling** – Cost effective Ethernet cabling can be used for the transfer of information to the Blue Heat/Net Sync and often this is part of the existing networking infrastructure. Connecting serial ports in a remote location can be as easy as plugging in a Blue Heat/Net Sync to the Ethernet network. This provides a simple, clean cabling arrangement.
- **Port Sharing** – In some applications it is desirable to have a serial resource that is accessed and shared by more than one host computer. Connect Tech's virtual serial port technology allows this to be done easily.
- **Routing** – Different ports on a Blue Heat/Net Sync can be connected to multiple host computers.
- **Monitoring** – Because the virtual serial ports are on the network, they can easily be monitored to ensure everything is operating correctly.

## Blue Heat/Net Sync Installation Overview

There are three main stages in the installation process for your Blue Heat/Net Sync.

1. [Hardware Installation](#)  
This involves the physical connection of the Blue Heat/Net Sync hardware to your network, and addresses issues such as cabling and power requirements.
2. [Blue Heat/Net Sync Configuration](#)  
The first step in the configuration process is to set the IP Address. Then use one of three available methods to configure the Blue Heat/Net Sync firmware settings for your application. This can be done through the [SCM \(Serial Configuration Manager\)](#) or the [WCM \(Web Configuration Manager\)](#), depending on circumstances and personal preference.
3. [Software Installation for Windows](#)  
This step installs and configures the Blue Heat/Net Sync drivers and ports for your host Operating System and allows you to set parameters specific to your serial requirements. This is done via the Blue Heat/Net Sync Configuration Manager.

**NOTE:** Software support for Windows and Linux is still in development

## Hardware Installation

### Connecting the Blue Heat/Net Sync to Your Network:

Before you begin, take a minute to ensure that your package includes the required components for your Blue Heat/Net Sync:

- One Blue Heat/Net Sync unit
- One power supply
- One CD containing software and documentation
- One Phoenix contact screw terminal plug PN: 1847055
- One RJ-45 cable (optional)

If any of these components is missing, [contact Connect Tech](#) or your reseller.

### Ethernet LEDs

The front panel of the Blue Heat/Net Sync features Ethernet and serial port LEDs to monitor activity.

**Power:** When this LED is on, the Blue Heat/Net Sync is receiving power.

**CPU:** Once the uClinux firmware is booted and running correctly, this LED lights up.

**10/100:** This LED represents the line rate at which the Blue Heat/Net Sync is connected to your network.

- LED on = a 100 megabit connection.
- LED off = a 10 megabit connection.

(The Blue Heat/Net Sync automatically detects the line rate of your network).

**L/A:** This light illuminates when the connection to your network or computer is achieved.

A blinking light indicates that Transmit (Tx) or Receive (Rx) activity is detected on the Ethernet cable.

**FD:** Indicates that your network is running in full duplex or half duplex mode:  
ON = full duplex, OFF = half duplex

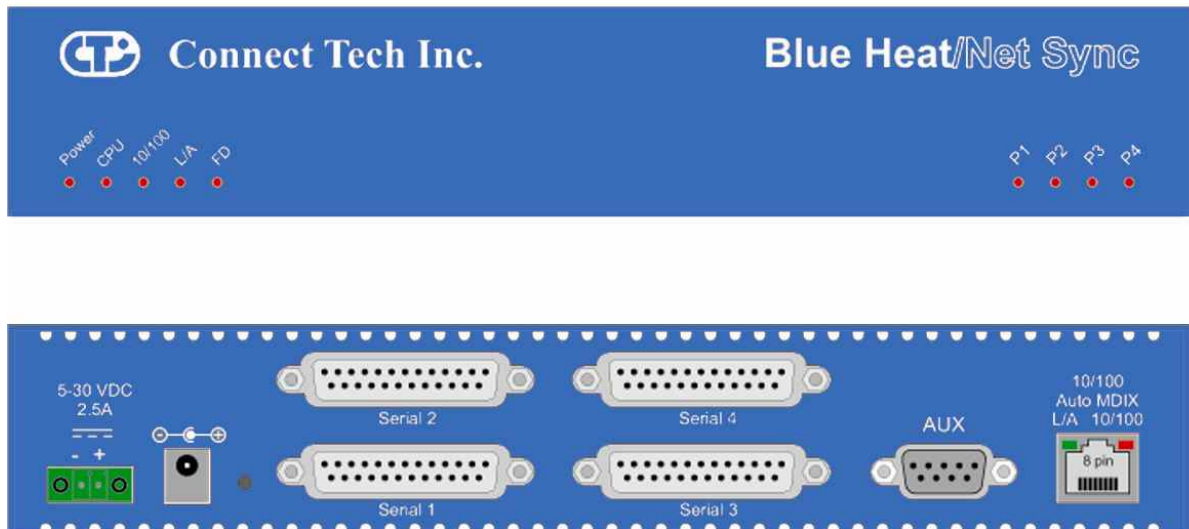


Figure 1: LED Locations on Blue Heat/Net Sync

## Serial Port LEDs

The serial ports LEDs indicate serial activity for each port.

- A flashing LED indicates that the port in question is receiving or transmitting data.

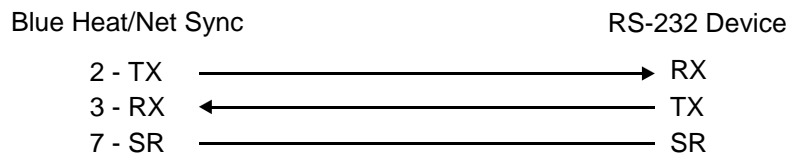
## Connecting Serial Devices

### V.28 Connections:

V.28 has signaling levels the same EIA RS232.

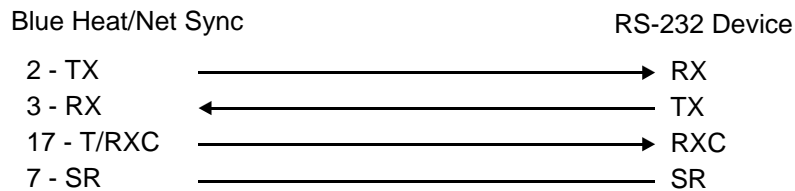
#### *Basic Async (V.28) RS-232 Null Modem Connection*

This is the typical way to connect a Blue Heat/Net Sync to another serial device.



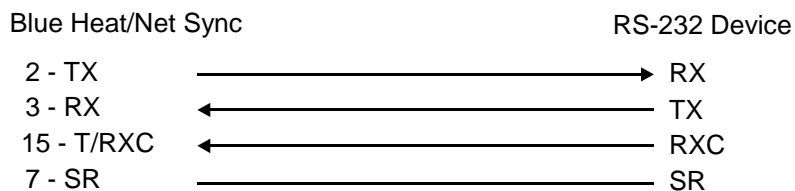
**Figure 2: Basic V.28 Asynchronous Connections**

#### *Basic Sync (V.28) RS-232 Connection (Provides Clock)*



**Figure 3: Basic V.28 Synchronous Connections**

#### *Basic Sync (V.28) RS-232 Connection (Receives Clock)*

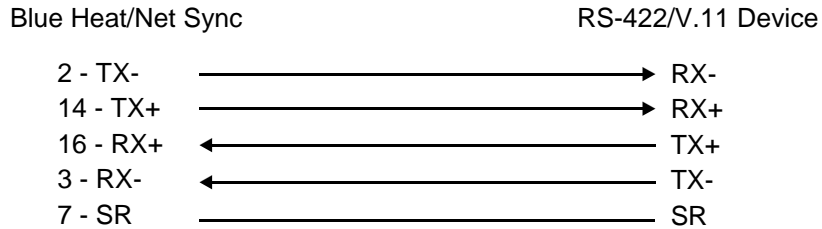


**Figure 4: Basic V.28 Synchronous Connections**

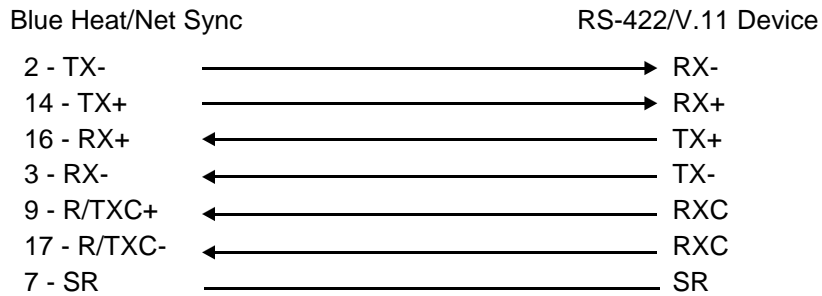
NOTE: The Blue Heat/Net Sync clock signals are bidirectional. See [Blue Heat/Net Sync Clocking](#) for more details.

## RS-422/V.11 Connections

The following are basic connections that can be accomplished when the I/O levels are in V.11 (RS-422) mode. V.11 mode signaling can be enabled with EIA-530, RS-449 or X.21 modes on your Blue Heat/Net Sync.



**Figure 5: Basic RS-422/V.11 Asynchronous Connections**



**Figure 6: Basic RS422/V.11 Synchronous Connections**

NOTE: Blue Heat/Net Sync clock signals are bidirectional. The Blue Heat/Net Sync can either source or receive a clock. See [Blue Heat/Net Sync Clocking](#) for more details.

## Blue Heat/Net Synchronous Clocking

The clocking circuits on the Blue Heat/Net Sync are very flexible. The Blue Heat/Net Sync DB-25 clock pins are bi-directional. This means that the TXC or RXC pins can be inputs receiving a clock or outputs driving a clock. Functionally the two pins are equal. For example, the following clocking combinations are possible:

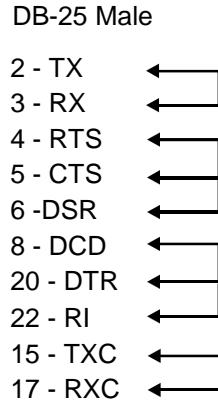
- RXC as clock input and TXC as clock input.
- RXC as clock output and TXC as clock output.
- RXC as clock input and TXC as clock output.
- RXC as clock output and TXC as clock input.

The Blue Heat/Net Sync receivers and transmitters can be clocked independently from any combination of the above or from internal clock sources.

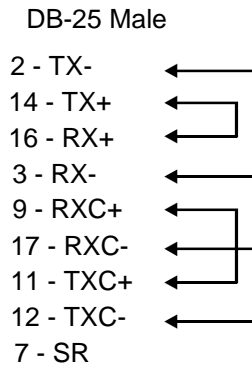
Clocking is also available from the EXT\_REF\_CLK input pin on the DB-9 female.

## Loopback Connectors

Loopback connectors are useful for performing diagnostics. The following figure illustrates the recommended pinouts for creating loopback connectors for Blue Heat/Net Sync.



**Figure 7: Recommended Pinouts for V.28 (RS-232) Loopback Connector**



**Figure 8: Recommended Pinouts for a V.11 (RS422) Loopback Connector**

**NOTES:**

1. For an asynchronous loopback, omit the TXC and RXC pin.
2. When using clock signals, one signal must be configured as an input, while the other must be configured as an output.
3. When using a DB-25 female loopback connector, solder cup DB-25 connectors and 24 AWG solid core wire, such as wire from a CAT5 cable is recommended.

## Connecting Power

The Blue Heat/Net Sync uses either a standard DC power jack or a Phoenix locking screw terminal connector for power input. The Blue Heat/Net Sync can be safely connected or disconnected at any time. The standard power supply requirements are as follows:

### Model BMG006

- 5V (2.5A) power input using a DC barrel or Phoenix screw terminal connector. Rev A models.
- 5V (2.5A) – 28 V DC (450mA) power input using a DC barrel or Phoenix screw terminal connector. **Rev B or greater models only.**

### DC Power Connector

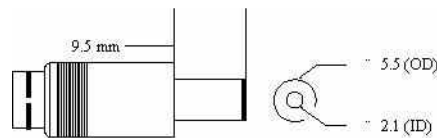


Figure 9: DC Power Connector Illustration

NOTE: The center is positive, outside is ground (0V).

### Phoenix Locking Screw Terminal Connector

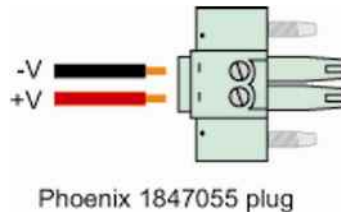


Figure 10: Phoenix Locking Screw Terminal Power Connector Illustration

## Activating the Special Operations Mode and Default Settings

Blue Heat/Net Sync includes a push button on the rear of the unit beside the DC power connector. This push button can be used to perform special operations such as resetting the unit to its default settings or forcing port scanning in situations where the SCM is not accessible.

### Using the Reset Button to Activate the Special Operations Mode

To activate the Special Operations Mode, hold the reset button while the unit is powering up. Hold the button until **all** the port LEDs blink rapidly and then release the reset button. The port LEDs will continue to flash rapidly after the reset button is released to indicate the Special Operations Mode is active.

## Selecting a Special Operation

Once the Special Operations Mode has been activated, four operation options are available:

- 1. Abandon the Special Operations Mode**

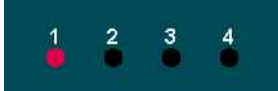
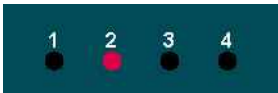
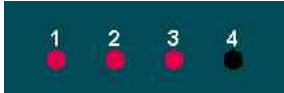
To abandon the Special Operations Mode without selecting a special operation, press and hold the reset button for at least four seconds. While the button is pressed, the rapid flashing of the port LEDs will stop. After four seconds, the rapid flashing will resume and the reset button can be released. After the release of the reset button, the port LEDs will turn off, indicating that the Special Operations Mode has terminated.
- 2. Cancel a Special Operation**

If you need to cancel a special operation after it has been selected, repeatedly press the reset button until all the port LEDs begin to flash rapidly. Then abandon the Special Operations Mode by pressing the reset button for four seconds, as explained above.
- 3. Select a Special Operation**

Operations are selected by repeated **short presses** of the reset button. Each time the reset button is pressed it is counted and represented on the port LEDs as a binary number with the port 1 LED as the least significant bit ([see Table 1](#)). Choose the operation which you want to perform. If you miss the selection that you want, keep pressing the button. The count starts over again once it reaches 7 (1111 binary).
- 4. Activate a Special Operation**

To activate a selection, press and hold the reset button for at least four seconds. During this time the rapid flashing of the port LEDs will stop. Once the rapid flashing resumes you can release the reset button. The port LEDs will turn off indicating that the Special Operations Mode has been activated.

**Table 1: Available Special Operations**

Special Operation	Number of presses (and binary representation)	Usage
Force port scanning to first two ports (Scanning runs until current scanning delay setting times out. Default is 30 seconds).	ONE press 	This forces the first two ports to RS-232 mode, causing the SCM to scan these ports and thereby allowing access to the SCM (see note below).
Force port scanning to all ports. (Scanning runs until the SCM is entered or until the unit is powered down. There is no time out).	TWO presses 	This forces all ports to RS-232 mode, therefore all ports are scanned for SCM use. The Blue Heat/Net Sync will behave in the same manner as an RS-232 only model (see note below).
Restore factory default settings	SEVEN presses 	This restores the factory default settings for <b>ALL</b> configuration parameters.

**NOTE:** Why would I need to force port scanning?

Some line interface settings are inappropriate for SCM use. During boot up, the SCM scans only those ports set for RS-232 mode. If all of the ports are configured for another mode, (1/2 Duplex or Multi-drop) SCM port scanning is bypassed, and the SCM application cannot be accessed. Use of either of the “Force Port Scanning” operations outlined in [Table 1](#) will force port scanning to occur so the SCM application can be accessed.

**Power On Diagnostics:**

**LED Error Codes**

If an error is detected during the bootup process, an error **condition** and **code** are displayed on the LEDs on the face of the Blue Heat/Net Sync.

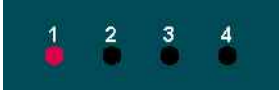
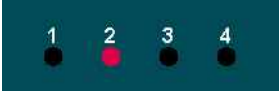
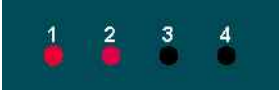
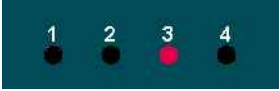
- The error **condition** is signaled by a rapidly flashing CPU LED (about 10 to 20 per second).
- The error **code** is displayed on Port LEDs 1 to 4 as a binary number.

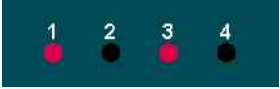
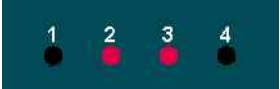
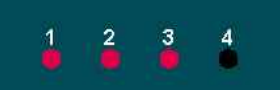
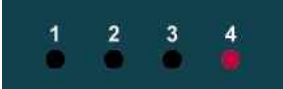
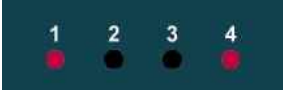


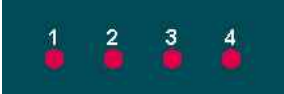
**Figure 11: LED Error Code Example**

In the above example, a rapidly flashing CPU LED during the boot up process signifies the Blue Heat/Net Sync has experienced an error. Port LEDs 1 through 4 signify which error has occurred. In this case, LED 2 and 3 are on, so the error code is 6. The chart below defines the error details for each error code.

**Table 2: LED Error Codes for Blue Heat/Net Sync**

Error Code and Event	Details	Suggested Corrective Action
<p><b>1.</b> Loader code in flash is erased.</p> 	<p>The regions of flash memory which hold the <b>loader code</b> are both erased. (There are two redundant loaders in flash that can be run).</p>	<p>This may occur in when there are ESD disturbances or in electrically noisy environments. If this error persists it may be a hardware issue. Contact <a href="#">Connect Tech</a>.</p>
<p><b>2.</b> Loader code in flash has a bad CRC.</p> 	<p>The regions of flash memory which hold the <b>loader code</b> both have CRC errors. (There are two redundant loaders in flash that can be run).</p>	<p>See corrective action for error code 1.</p>
<p><b>3.</b> RAM copy of loader code has a bad CRC.</p> 	<p>The <b>loader code</b> is copied to RAM before execution. This error is shown if the RAM copy has a CRC error.</p>	<p>See corrective action for error code 1.</p>
<p><b>4.</b> Configuration Data Space (CDS) areas have corrupted data (CRC failure).</p> 	<p>The CDS is copied from flash to RAM during the beginning of the <b>loader code</b>. If a CRC error is detected in the RAM copy, this error is shown.</p>	<p>See corrective action for error code 1.</p>

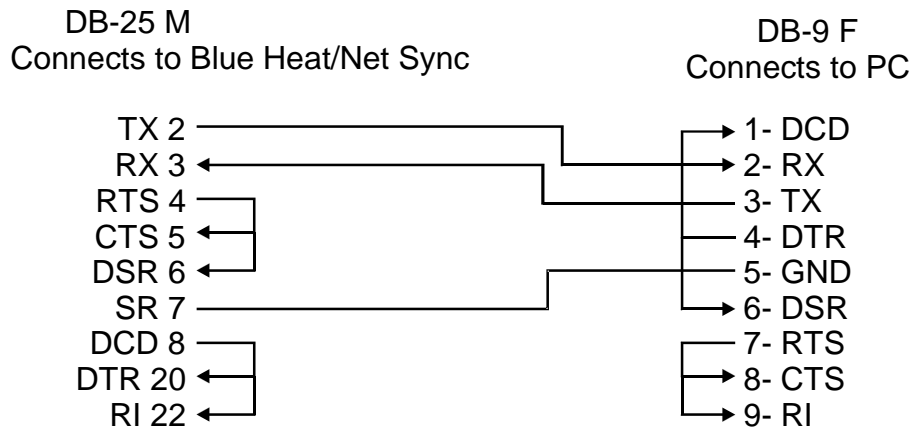
<p><b>5.</b> Cannot obtain an operating system image (uClinux) to run.</p> 	<p>This will occur when <b>any</b> of the <b>enabled</b> boot sources (flash or BOOTP/TFTP or TFTP) fail to obtain a valid compressed operating system image to run.</p>	<p>Check network connections, server computer or your unit's settings. This error occurs if TFTP booting is enabled and the Blue Heat/Net Sync cannot download the file from the server. Contact <a href="#">Connect Tech</a> if it persists.</p>
<p><b>6.</b> Unexpected return from the uClinux operating system.</p> 	<p>This error occurs if the operating system returns back to the loader.</p>	<p>See corrective action for error code 1.</p>
<p><b>7.</b> CDS re-programming failure.</p> 	<p>Certain CDS items are updated during the bootup. If a failure occurs during the re-programming of the flash, this error will occur.</p>	<p>See corrective action for error code 1.</p>
<p><b>8.</b> Boot count could not be incremented in flash memory</p> 	<p>This error is usually caused by a Flash memory failure.</p>	<p>Contact <a href="#">Connect Tech</a>.</p>
<p><b>9.</b> No ports found</p> 	<p>This message usually indicates a UART component failure.</p>	<p>Contact <a href="#">Connect Tech</a>.</p>

<p><b>15.</b> Mismatched CDS version number</p> 	<p>uClinux checks the CDS version number against its expected CDS version number. If they are different, uClinux does not continue its operation.</p>	<p>If you have updated the uClinux code via SCM and have not updated the loader/SCM code, this error appears on reboot. Update companion loader code and reboot.</p>
---	---	--

## SCM Cabling requirements

### SCM: Serial Configuration Manager

The Serial Configuration Manager is used to configure the Blue Heat/Net Sync via a serial port and is discussed in greater detail later in this document. To access the Serial Configuration Manager you will need to connect an RS-232 (V.28) serial cable from your standard computer serial port to any RS-232 (V.28) port on the Blue Heat/Net Sync. The cabling required to connect to the Blue Heat/Net Sync is as follows:



**Figure 12: Blue Heat/Net Sync Serial Cable Connection Diagram**

The key signal connections are RX, TX and GND. The other signals may not be required in your application. If you are assembling your own SCM cable, we recommend that all of the above connections be made.

## Setting a Static or Dynamic IP Address

Prior to configuring the Blue Heat/Net Sync, you must set a static or dynamic IP address. The default IP address of a new Blue Heat/Net Sync is 192.168.42.1. If there is a possibility that this has been changed, you will need to find the current IP address setting before you begin.

The easiest way to get the IP address of your Blue Heat/Net Sync is as follows: Follow the steps outlined in the section [Installing the Blue Heat/Net Sync Configuration Manager](#) and noting your Blue Heat/Net Sync's IP number (i.e. **A.B.C.D**) using the [Auto Discover Blue Heat/Net Sync](#) feature.

## Set the IP Address Using the Web Configuration Manager

**NOTE:** If you use the Windows Configuration Manager and use Auto Discover to locate your Blue Heat/Net Sync on the network, you can right-click and launch the Web Configuration Manager from there. You only need to use the route add command if you choose not to use the Configuration Manager found on the CD that accompanied your Blue Heat/Net Sync unit.

From the command prompt of your computer, run: **route add A.B.C.0 mask 255.255.255.0 <current IP of your host machine>** Be sure to replace the **.D** from the Blue Heat/Net Sync's IP with a **0** (zero). Open your browser and put the Blue Heat/Net Sync's IP in the address bar (i.e. **A.B.C.D**) This will open the WCM. Log in (default login is **wcm** and the default password is **password**) and assign the static IP or change the IP to 0.0.0.0 if you are using a DHCP assigned IP.

## Set the IP Address Using the Serial Configuration Manager

Insert your CD into the computer and complete the following steps:

1. Once your CD has been inserted, the Driver/Software Installation menu should appear. If it doesn't, double-click on **ctisetup.htm**.
2. Click **View** in the Blue Heat/Net Sync Software section and then **Connect** in the Serial Configuration Manager section. This will launch HyperTerminal that comes with Windows XP.
3. Unplug the power to the Blue Heat/Net Sync and plug it back in. Light indicators 1 to 4 will blink sequentially. This sequential flashing will last for 30 seconds. **You must log in during this window.**
4. During this sequential flashing, type the word **password** into the HyperTerminal window. Be careful you do not miss the window of opportunity to enter the password.
5. You now have access to the Serial Configuration Manager (SCM). An **scm>** prompt is ready to accept commands. If you do not see this prompt, unplug the power and repeat the steps above.

If you wish to set a dynamic IP address enter the following:

```
net dhcp=yes  
save  
exit
```

If you wish to set a static IP address, enter the following, substituting **xxx.xxx.xxx.xxx** with the static IP you wish to assign:

```
net mip=xxx.xxx.xxx.xxx  
save  
exit
```

Close the HyperTerminal. You may now disconnect the DB-25 cable from your PC and connect it to any serial device

## Blue Heat/Net Sync Configuration

The Blue Heat/Net Sync comprises several software components, each of which manages various functions of the Blue Heat/Net Sync. The following is a breakdown of these components.

- **Operating System Software**
  - Host Operating System Driver
  - Configuration Manager
  - Web browser (Host Operating System supplied)
  
- **Blue Heat/Net Sync Software (Firmware)**
  - Embedded Operating System (uClinux)
    - Kernel
    - Drivers
      - Ethernet
      - Serial
      - Flash
    - Blue Heat/Net Sync Ethernet Protocol Converter application (Ctid)
    - Web server (Boa)
    - Web pages
    - Telnet services
  - PPP Client and PPP Server
  - Bootloader
  - Serial Configuration Manager (SCM) Application
  - Configuration Data Space (CDS)

The following section describes in brief what each main component controls.

### Host Operating System Driver

The host operating system driver performs the translation from a standard serial COM port interface to the Blue Heat/Net Sync protocol (which is then delivered to the LAN as described above).

### Configuration Manager

This software manages and configures the relationships between the Blue Heat/Net Sync serial ports and the COM port assignments of the Host Operating System.

### Web Browser

The host operating system supplies a Web Browser to support the Web Configuration Manager (WCM) used to change the configuration settings of Blue Heat/Net Sync units.

### Embedded Operating System

The embedded operating system is uClinux.

### PPP Client and PPP Server

A Blue Heat/Net Sync port can behave as a PPP connection, enabling you to run network protocols over a serial link. PPP connections are often used in applications that require remote monitoring. You can set the Blue Heat/Net Sync to behave as either the dial out or “client” side (PPP Originate) or the answering or “server” side (PPP Answer).

### Bootloader

This code first starts up the embedded processor of the Blue Heat/Net Sync from a power-up or software initiated reboot. It then obtains the embedded operating system image (file) from one of several locations and runs the operating system.

### **Serial Configuration Manager (SCM) Application**

This application is used to change the configuration settings of Blue Heat/Net Sync units by connecting to a serial port on the Blue Heat/Net Sync from a terminal (or terminal emulation program on a PC).

### **Configuration Data Space (CDS)**

This is the area, in non-volatile (flash) memory, which stores the configuration parameters.

## ***CDS (Configuration Data Space)***

### ***Description***

The Blue Heat/Net Sync has a number of configuration parameters which are stored in a **non-volatile** (flash memory) area. (See appendix for list of parameters).

The CDS area is stored **redundantly** in the flash memory along with a **CRC**-style checksum to ensure data integrity.

### ***Access to CDS Parameters***

The parameters stored in the CDS can be changed through the use of the following configuration tools:

SCM Serial Configuration Manager

WCM Web Configuration Manager

These three methods allow the user to change configuration parameters by the method that is most convenient. In some cases several methods will be employed during different stages of the setup of the Blue Heat/Net Sync. For example:

The SCM may be employed in the beginning when the unit is not connected to a network and various networking parameters need to be set up prior to connection to a network.

WCM may be employed after the unit is connected to a network, possibly to modify other settings related to serial ports, bootup settings or others.

More information about the operation of the [SCM Command Reference](#) and [WCM \(Web Configuration Manager\)](#) follows.

**NOTE:** When CDS parameters are changed via the SCM or WCM some settings will not take effect until the Blue Heat/Net Sync is rebooted.

## SCM (Serial Configuration Manager)

### Description

The Serial Configuration Manager is one of the applications you can use to access the Configuration Data Space (CDS) settings of the Blue Heat/Net Sync. Since the CDS stores the default serial port settings, it is important that the line mode is configured prior to first use. Accessing the ports will not be possible otherwise.

### Getting Access to the SCM

To access the SCM, simply connect a serial port terminal device (or a PC running a terminal emulator program) to any of the serial ports on the Blue Heat/Net Sync and enter a correct **Password**. A command prompt is then sent to the terminal and CDS parameters can be changed using a command line style of entry.

Blue Heat/Net Sync has **configurable line interfaces**. Certain settings can affect access to the SCM. The ports are scanned as follows:

The default line mode setting of **all** ports is **Undefined**. Under these conditions, the first two ports are set to RS-232 mode during port scanning. Access to the SCM is available through these ports only (you should set all ports to a known state prior to use).

When a port is set to something other than **Undefined**, any port with a setting of RS-232 or RS-485 Full Duplex will be scanned. Otherwise, scanning is not performed and access to SCM is not available.

**NOTE:** To access the Blue Heat/Net Sync via the SCM your serial line interface settings must be at the default values of 9600 baud, 8 data bits, no parity and 1 stop bit (9600, 8, n, 1). No flow control is recommended.

In a situation where port scanning is not performed, you can still access the SCM using the push button reset on the back of the unit. Follow the instructions in the section [Activating the Special Operations Mode and Default Settings](#) to access the SCM in this situation

See the section which describes how the Blue Heat/Net Sync boots for a complete description of the **Bootup** process of the Blue Heat/Net Sync and how to access the SCM.

### SCM Command Reference

SCM commands are entered as strings of ASCII characters with options separated by whitespace characters. The entire command line is terminated by a CR character or CR/LF character pair.

Command lines can be entered manually (via a terminal or a PC with terminal emulator program) or sent from an application program.

If an SCM command is entered with no options specified, the command shows the syntax of its options and the current setting of those options.

#### Brief Command List

- [boot](#) Bootup settings
- [cfg](#) SCM operational settings
- [exit](#) Exits the SCM application (and optionally reboots the Blue Heat/Net Sync)
- [help](#) Brief list of available commands and their syntax
- [info](#) Blue Heat/Net Sync general information and flash verification
- [net](#) Network settings

- [save](#) Save setting changes to non-volatile flash storage
- [update](#) Download a new operating system via TFTP and flash, (uClinux) and loader/SCM image.

### Command Details

#### boot

- Syntax: **boot [mode=] [file=] [delay=]**
- Description: This command establishes the Blue Heat/Net Sync boot-up mode. For a detailed description of the boot-up process of the Blue Heat/Net Sync, see [How the Blue Heat/Net Sync Boots Up](#) in the Appendix.
- Options: **mode=**  
A comma-separated list of the following sub-options. Each sub-option is preceded by either a + or a – to indicate if the sub-option is enabled or disabled.  
**±flash** Enables or disables the ability to boot from the flash memory.  
**±bootp** Enables or disables the ability to obtain the boot-up information from a Server.  
**±tftp** Enables or disables the ability to download and boot from a file located on a Server.
- file=**  
This option specifies the default file name used for the boot-up (if TFTP boot is enabled) and also the default file name when using the **flos** command. This can be any sequence of characters up to 128 characters in length. (The default is **BHNUclinux\_vvv.gz**, where vvv is the current version number of the “Operating System image”).
- delay=**  
This sets the time duration for accessing the SCM application. It can be set from 2 to 30 seconds, the **default is 30**. (See the section [How the Blue Heat/Net Sync Boots Up](#) for more information).

#### cfg

- Syntax: **cfg [port=] [timeout=] [password=] [prompt=] [file=]**
- Description: Establishes the settings used by the SCM application to modify its behavior.
- Options: **port=**  
Specifies the port number to scan for a password to gain entry in the SCM.  
**N** = Scan just port N (N=1 to the number of ports on the unit).  
**255** = Scan all ports on the unit (default unless unit has programmable line interfaces).
- timeout=**  
Specifies the time duration allowed for a TCM (via telnet) session to be idle (no activity) before the session is terminated.  
0 to 1092 minutes  
(default = 5)  
Note: A setting of zero allows infinite timeout.

**NOTE: The TCM function is currently not available with this product.**

**password=**

This sets the password phrase, which is used to gain access to the SCM and WCM modes of configuring the Blue Heat/Net. The default is “password”.

**prompt=**

This setting controls whether a password prompt (and other password entry status information) is presented to the terminal. This prompting is helpful for new users of the product but may present a problem when other devices are connected to the serial port.

**yes** enables the password prompting (default)

**no** disables the password prompting

**file=**

This sets the file name used as a default when using the **fldr** command. It can be any sequence of characters up to 128 characters in length. (The default is “BHNloader\_vvv.gz”, where vvv is the current version number of the “Loader”).

**exit**

Syntax: **exit [-nosave] [-no\_reset][-login]**

Description: This command is to exit the SCM and reboot the Blue Heat/Net Sync. If CDS changes have been made a warning message is issued and the SCM will not exit.

Options: **-nosave**  
Exit without saving changes (abandon changes).

**-no\_reset**  
Exit SCM without rebooting, maintaining the changes to settings for this session only. (Booting is continued after the SCM is exited.)

**-login**  
Exit without saving changes, and restart the SCM login process.

**help**

Syntax: **help**

Description: Displays a brief list of all the commands.

Options: There are no options for the help command. Please note that specific help for the options of each command can be obtained by entering any command with a single “?” argument. An example would be **net ?**

**info**

Syntax: **info [-v]**

Description: This command is used to show basic information about the Blue Heat/Net Sync unit, like Serial Number and Version Numbers, and performs a confidence (CRC and Decompression verification) test of the contents of the flash memory.

Options: **-v**  
This option disables the confidence tests.

**net**

Syntax: **net [network= | net=]**

[my\_ip= | mip=]  
[server\_ip= | sip=]  
[gateway\_ip= | gip=]  
[subnetmask= | snm=]  
[broadcast\_ip= | bcip=]  
[dns\_ip=]  
[domain=]  
[host name=1 host=]  
[tcp=]  
[mac=]  
[dhcp=]

Description: Establishes the network settings.

Options: **network= | net=**  
Sets the “network” portion of the IP address into **my\_ip**, **server\_ip** and **gateway\_ip**. The address entered is masked by the subnet mask setting before being applied. This command is a shortcut for quickly setting all the IP addresses of the unit. See note below.

**my\_ip= | mip=**

This sets the IP address of the Blue Heat/Net Sync unit (default is 192.168.42.1). See note below.

**server\_ip= | sip=**

This sets the Server IP address. This address determines the address of the Server to use when the **Bootp** and **tftp** mode is enabled (see **boot** command), and also as the default Server address to use for the **update** commands (default is **0.0.0.0**). See note below.

**gateway\_ip= | gip=**

This sets the Gateway IP address. This address is used when the **Bootp** mode is enabled, default is **0.0.0.0**. See note below.

**subnetmask= | snm=**

This sets the Subnet mask IP address. (The default is **255.255.255.0**) See note 1.

**broadcast\_ip= | bcip=**

This sets the Broadcast IP address. This is used when the **Bootp** mode is enabled. (The default **255.255.255.255**). See note below.

**dns\_ip=**

This sets the IP of Domain Name Server. (The default is 0.0.0.0). This must be set to update the Blue Heat/Net Sync firmware automatically from Connect Tech’s anonymous ftp server.

**domain=**

This sets the Domain name of the unit. (The default is **blueheat.net**)

**Host name=1 host =**

This sets the Host name of the Blue Heat/Net Sync unit. (The default is **BHNsssssss**, where “sssssss” is the serial number of the unit).

**tcp=**

This sets the base TCP port number used for Host TCP/IP and UDP/IP communications. The default is 49152 (0xC000)

**mac=**

This displays the MAC address of the unit. (The default is **00:0C:8B:SS:SS:SS**, where **SS:SS:SS** is the hex value of the serial number of the unit). Note: The MAC address **cannot** be changed, it can only be displayed.

**dhcp=**

This enables or disables DHCP support.

**yes** enables

**no** disables (default)

**NOTES:**

All IP addresses are entered in common IP address notation: **ddd.ddd.ddd.ddd** where **ddd** is a decimal number from 0 to 255.

IP address "**my\_ip, server\_ip, gateway\_ip** and **dns\_ip**" can be entered right justified, meaning that the address entered will be applied to the specified address starting from the least significant digit, masked by the subnet mask. For example:

If the subnet mask is set to **255.255.255.0**, and the following command is entered:

**net net=12.23.34.00 mip=45 sip=56 gip=67 dns\_ip=89**

The following IP addresses result:

the Blue Heat/Net Sync unit will be

12.23.34.45

the Server will be

12.23.34.56

the Gateway will be

12.23.34.67

and the DNS IP will be

12.23.34.89

**save**

Syntax: **save**

Description: This command saves the setting changes into the CDS in the non-volatile (flash) memory.

Options: (none)

**update**

Syntax: **update <-os | -loader | -jffs> [server\_ip= | sip=] [file=]**

Description: Download and store (in flash memory) a new uClinix Operating System image or a new Loader/SCM image. The download is conducted by a TFTP download from a Server. After download the image file is checked as being a valid gzip file (file is decompressed to validate its contents), and then the file is stored in flash memory. The **OS** file is stored in flash in its compressed form, but the **Loader** is stored uncompressed.

Options: **-os | -loader | -jffs**

Use **-os** to update the uClinix OS.

Use **-loader** to update the loader/SCM.

Use **-jffs** to update the JFFS system (Journaling Flash File System).

**server\_ip= | sip=**

Specify the Server IP address from which the file is to be downloaded.

**file=**

Specify the file name to download. If the **-jffs** option is chosen, then the **file=** option is mandatory.

**NOTE:** After downloading, the image is checked to ensure the file is correctly formatted. If the file is bad the command exits. The version is checked against your current version. If they match, you will be prompted to choose if you wish to program the flash. Enter "y" to continue. If the version is different, the new version needs to be saved with the **save** command when the update is finished.  
When the JFFS is updated, all previous contents are destroyed. Only use this option when updating to a Blue Heat/Net Sync that supports Personality settings.

## WCM (Web Configuration Manager)

### Signing In to the Web Configuration Manager

You will need to know the IP address of your Blue Heat/Net Sync unit before you use the Web Configuration Manager. Use the Serial Configuration Manager to assign the Blue Heat/Net Sync a valid IP address, or tell the Blue Heat/Net Sync to use DHCP to automatically obtain an IP address. Please refer to the [SCM Command Reference](#) documentation for information on how to do this.

Once you know your IP address, open your web browser and go to: `http://_your_ip_address_/` or `http://www.hostname.com/`

You will arrive at the Blue Heat/Net Sync Web Configuration Manager Sign In page. The default username is **wcm**. Leave this name as is. The default password is **password**. Use this username/password combination and click the **Sign In** button to log on to the Web Configuration Manager.

The screenshot shows the Blue Heat/Net Web Configuration Manager interface. At the top, there is a header with 'Your Blue Heat/Net IP' (206.130.75.104) and 'Blue Heat/Net' logo. A navigation menu on the left includes 'Home', 'Configure' (with sub-items like Advanced Serial Settings, Sync Serial Settings, Security Settings, Blue Heat/Net Settings, Change Your Password, Firmware, Reboot, Restore Defaults), 'Monitor' (with sub-items like Serial Port Traffic, Network Traffic, TCP/IP Statistics, My Blue Heat/Net), and 'Help' (with sub-items like FAQ, Documentation, Contact Us). The main content area is titled 'Web Configuration Manager Sign In' and contains a login form with 'Login' (wcm) and 'Password' (password) fields, a 'Sign In' button, and a 'Forgot your password?' link.

**Figure 13: Web Configuration Manager Sign In**

Once you have signed in, you should immediately change the default password.

At this point you should be directed to the Web Configuration Manager homepage.

To sign out of the Web Configuration Manager, just click on the Sign Out link on the upper right hand side of the Web Configuration Manager.

Signed In: wcm@206.130.75.121
Help
Sign Out

**Your Blue Heat/Net IP**  
206.130.75.104

**GP Blue Heat/Net**

[Save To Flash](#)

This section allows you to configure Blue Heat/Net Sync system properties. The [help](#) section describes each configuration parameter in detail.

[Home](#)

**Configure**

[Advanced Serial Settings](#)

**Sync Serial Settings**

[Security Settings](#)

[Blue Heat/Net Settings](#)

[Change Your Password](#)

[Firmware](#)

[Reboot](#)

[Restore Defaults](#)

**Monitor**

[Serial Port Traffic](#)

[Network Traffic](#)

[TCP/IP Statistics](#)

[My Blue Heat/Net](#)

**Help**

[FAQ](#)

[Documentation](#)

[Contact Us](#)

Port 1
Port 2
Port 3
Port 4

**Clock Tree Settings**

Tx Mode	Async	Rx Mode	Async
Tx Clk Tree Level A	None	Rx Clk Tree Level A	BRG 0
Tx Clk Tree Level B	BRG0	Rx Clk Tree Level B	BRG0
Tx Clk Tree Level C	CTR0	Rx Clk Tree Level C	CTR0
Tx Clk Tree Level D	Ref	Rx Clk Tree Level D	Ref
Tx C Pin Mode	Input	Rx C Pin Mode	Input

**Timing Control**

Tx Ref Freq	18432000	Rx Ref Freq	18432000
Tx BPS Error (PPM)	500	Rx BPS Error (PPM)	10000
Tx BPS	9600	Rx BPS	9600
Tx BPS Frac	0	Rx BPS Frac	0
Tx Async Div	16	Rx Async Div	16
Tx DPLL Div	8	Rx DPLL Div	8
Tx CTR Div	4	Rx CTR Div	4

**Interface & Encoding**

Line Mode	V28 (RS232)	Line Termination	<input type="radio"/> On <input checked="" type="radio"/> Off
Tx Encoding	NRZ	Rx Encoding	NRZ

**Tx PreAmble & Idle Pattern**

Preamble	Disable	Length	8
Idle	Default		

**Duplex Settings**

Duplex Mode	Full
-------------	------

**Sync chars**

Tx 0	00	Rx 0	00
Tx 1	00	Rx 1	00
Length	= Data Bits	Length	= Data Bits
Strip Sync	<input type="radio"/> Yes <input checked="" type="radio"/> No		

**Data Bits & Parity**

Tx Data bits	8	Rx Data bits	8
Tx Parity	None	Rx Parity	None

**CRC**

Tx Type	None	Rx Type	None
Tx Start	Start with all zeros	Rx Start	Start with all zeros
Tx Mode	Tx Underrun		
EOF/M Char	00		

**Trigger & Gating**

Tx Trig/Gate	Disable	Rx Gated	Disable
--------------	---------	----------	---------

**Async Settings**

Software Flow Control	<input checked="" type="radio"/> On <input type="radio"/> Off	Xon Char	11	Xoff Char	13
Hardware Flow Control Tx CTS	<input type="radio"/> On <input checked="" type="radio"/> Off	Hardware Flow Control Rx RTS	<input type="radio"/> On <input checked="" type="radio"/> Off <input type="radio"/> Toggle		
Hardware Flow Control Tx DSR	<input type="radio"/> On <input checked="" type="radio"/> Off	Hardware Flow Control Rx DTR	<input type="radio"/> On <input checked="" type="radio"/> Off		

**Special Modes**

Error	<input type="radio"/> On <input checked="" type="radio"/> Off	Char	01
Break	<input type="radio"/> On <input checked="" type="radio"/> Off	Char	00
Event	<input type="radio"/> On <input checked="" type="radio"/> Off	Char	00
Escape	<input type="radio"/> On <input checked="" type="radio"/> Off	Char	00

**Fifos**

Tx Enable	<input checked="" type="radio"/> On <input type="radio"/> Off
Tx Load	80
Rx Threshold	01

Submit
Restore

Figure 14: Blue Heat/Net Sync Settings

### ***Configure Advanced Serial Settings***

The Web Configuration Manager also allows you to configure more advanced serial port properties. These advanced properties will allow you to configure the XOn Character, XOff Character, Break Character, Escape Character, Error Character and Event Character, and Transmit Load Setting for each serial port.

Further, you will be able to specify whether you want to enable Null Stripping or RTS Toggle for a particular port as well as the option to enable or disable the Break, Event and Error characters.

By default, all advanced serial properties are disabled. You should only use these advanced properties if you require them.

You are required to use the ASCII representation of characters using the respective hexadecimal values. For example, if you wanted your XOn character to be capital 'A', you would specify a hex value of 41.

We have provided you with an ASCII table on the Advanced Serial Port Properties page for your convenience. Click on the **ASCII Table** link, and an ASCII table will open in a new window.

Each serial port parameter has been abbreviated due to space constraints. We have provided another link which describes the abbreviated parameter descriptions. Click on the **Parameter Descriptions** link, and a new window will open which contains a description of each parameter.

### ***Configure Blue Heat/Net Sync Settings***

This section provides various Blue Heat/Net Sync Configuration options, and shows you the saved versus current settings. The details for each configuration option are provided below:

- **Flash Enabled:** This option enables or disables the ability of the Blue Heat/Net Sync to boot-up from flash memory.
- **Bootp Enabled:** This option enables or disables the Blue Heat/Net's ability to obtain boot-up information from the server (see "Server IP Address" below).
- **TFTP Enabled:** This option enables or disables the ability to download and boot from a file located on a server (see "Server IP Address" below).
- **DHCP Enabled:** This option enables or disables the use of DHCP. If DHCP is enabled, the Blue Heat/Net Sync will attempt to automatically obtain an IP address. If DHCP is disabled, you must manually specify an IP address for the Blue Heat/Net.
- **Configuration Port:** This option sets the port to scan for the password to gain entry into the Serial Configuration Manager. You can specify a particular port, or specify the **Scan All Ports** option. In this case the Blue Heat/Net Sync will scan all ports for the password when the Blue Heat/Net Sync is booting. The default setting is **Scan All Ports**.
- **Session Timeout:** This option specifies the time allowed between web page navigation. The default session timeout is 5 minutes. This means if the Web Configuration Manager has not received any requests for more than 5 minutes, you will be automatically logged out. You can set the timeout from 1 minute to 2 hours, or disable the session timeout all together by selecting the **Disable Timeout** option.
- **Boot Delay:** This option specifies time allowed for gaining access to the Serial Configuration Manager while the Blue Heat/Net Sync is booting. The time ranges from 2 seconds to 30 seconds. The default setting is 30 seconds.
- **Server IP Address:** This option sets the server IP address. This is used as the Server address to use when bootp mode or TFTP mode is enabled. The default Server IP address is 0.0.0.0

- **Blue Heat/Net Sync IP Address:** This option sets the IP address of your Blue Heat/Net. The default IP address for your Blue Heat/Net Sync is 192.168.42.1
- **Domain Name:** This option sets the domain name of your Blue Heat/Net. The default domain name is **blueheat.net**.
- **Host Name:** This option sets the hostname of your Blue Heat/Net. The default hostname is BHNssssss, where ssssss is your Blue Heat/Net Sync serial number.
- **Gateway IP Address:** This option sets the Gateway IP address for your Blue Heat/Net. The default Gateway IP address is 0.0.0.0
- **Broadcast IP Address:** This option sets the Broadcast IP address. The default Broadcast IP address is 255.255.255.255.
- **Subnet Mask:** This option sets the Subnet mask IP address. The default Subnet mask IP address is 255.255.255.0.
- **Bootfile Name:** This option specifies the default file name which will be used for Blue Heat/Net Sync boot-up, *if TFTP is enabled*. If TFTP is enabled, the Blue Heat/Net Sync will attempt to download the bootfile you specify from a Server IP address you specify (see "Server IP Address" above). The bootfile name should reference a valid uClinux kernel image. If TFTP is enabled, the Blue Heat/Net Sync unit will attempt to download this image, and will also attempt to decompress the image and run it.
- **TCP Port:** This option allows you to change the starting local TCP port that is used to service clients connecting to the Blue Heat/Net Sync unit. The default TCP port is 49152. When altering the TCP port on the Blue Heat/Net Sync unit, you must also alter it on the user's side.
- **Domain Server IP Address:** This option sets the Domain Name Server IP address. The default DNS IP address is 0.0.0.0.

After you've made any necessary configuration changes, click the **Submit** button at the bottom of the page. A confirmation page will show up confirming the Blue Heat/Net Sync changes.

The screenshot shows the Blue Heat/Net configuration web interface. At the top, it says "Signed In: wcm@206.130.75.121" and "Help Sign Out". The main header includes "Your Blue Heat/Net IP 206.130.75.104" and the "Blue Heat/Net" logo. A "Save To Flash" button is visible in the top right. The left sidebar contains navigation links for Home, Configure (Advanced Serial Settings, Sync Serial Settings, Security Settings, Blue Heat/Net Settings, Change Your Password, Firmware, Reboot, Restore Defaults), Monitor (Serial Port Traffic, Network Traffic, TCP/IP Statistics, My Blue Heat/Net), and Help (FAQ, Documentation, Contact Us). The main content area is titled "Blue Heat/Net" and contains a description: "This section allows you to configure Blue Heat/Net system properties. The help section describes each configuration parameter in detail." Below this, there are sections for "Boot Mode Settings" and "Blue Heat/Net Settings".

**Boot Mode Settings**

Flash Enabled	<input type="radio"/> Yes	<input checked="" type="radio"/> No
Bootp Enabled	<input type="radio"/> Yes	<input checked="" type="radio"/> No
tftp Enabled	<input checked="" type="radio"/> Yes	<input type="radio"/> No
Use DHCP	<input type="radio"/> Yes	<input checked="" type="radio"/> No

**Blue Heat/Net Settings**

Blue Heat/Net Settings	Saved Settings	Current Settings
Configuration Port	Scan All Ports	
Session Timeout	5 minutes	
Boot Delay	30 seconds	
Server IP Address	206.130.75.44	
Blue Heat/Net IP Address	206.130.75.104	206.130.75.104
	Apply On Sign Out	
	<input type="radio"/> Yes	<input checked="" type="radio"/> No
Domain Name	blueheat.net	blueheat.net
Hostname	BHN00004569	BHN00004569
Gateway IP Address	0.0.0.0	0.0.0.0
Broadcast IP Address	255.255.255.255	206.130.75.255
Subnet Mask	255.255.255.0	255.255.255.0
Bootfile Name	BHN5272uClinux_0.105_...	
TCP Port	49152	
DNS IP	0.0.0.0	

At the bottom of the settings table, there are "Submit" and "Restore Defaults" buttons.

Figure 15: Configuring Blue Heat/Net Sync Settings

## Configure Firmware

This section enables you to download new firmware to the Blue Heat/Net Sync unit. Select a download source and a specific firmware file path, if applicable, and then submit the download request. This section also provides a link to reboot your Blue Heat/Net. This is standard procedure after installing new firmware.

The screenshot displays the Blue Heat/Net web interface. At the top, it shows the user is signed in as 'wcm@206.130.75.121' and provides links for 'Help' and 'Sign Out'. The main header includes the 'Blue Heat/Net' logo and a 'Save To Flash' button. A left-hand navigation menu lists sections: Home, Configure (with sub-items: Advanced Serial Settings, Sync Serial Settings, Security Settings, Blue Heat/Net Settings, Change Your Password), Firmware (with sub-items: Reboot, Restore Defaults), Monitor (with sub-items: Serial Port Traffic, Network Traffic, TCP/IP Statistics, My Blue Heat/Net), and Help (with sub-items: FAQ, Documentation, Contact Us). The main content area is titled 'Firmware Download' and contains a text box for 'Download Source' with the value 'ftp.connecttech.com via anonymous FTP' and a 'Next' button. Below the text box, there is a paragraph of instructions: 'This section enables you to download new firmware to the Blue Heat/Net unit. You will have the option to upgrade from the Connect Tech Inc. website, a local file, or a local FTP server. Select a download source and a specific firmware file path, if applicable, and then submit the download request. After installing new firmware, it is standard procedure to reboot your Blue Heat/Net.' A note follows: 'Note: Installing the new firmware will reformat the JFFS2 file system. Any configuration changes to PPP, raw socket, RFC 2217, and Field Server will be lost.'

Figure 16: Firmware Upgrades/Downloads

## Restore Defaults

The Restore Defaults page enables you to quickly reset all or some of the default basic, advanced, security, Blue Heat/Net Sync or system settings of your Blue Heat/Net Sync.

**NOTE:** This function is not currently operational.

Signed In: wcm@206.130.75.121 Help [Sign Out](#)

**Your Blue Heat/Net IP**  
206.130.75.104 **Save To Flash**

**Blue Heat/Net**

This section allows you to restore your Blue Heat/Net settings back to their default values. From the list below, select the settings you wish to restore.

- Basic Serial Settings**  
Choosing this option will restore each port's basic serial settings to the following default values:  
Baud Rate: 9600    Flow Control: none  
Parity: none    Mode: Not Set  
Data Bits: 8    Personality: Blue Heat/Net  
Stop Bits: 1
- Advanced Serial Settings**  
Choosing this option will restore each port's advanced serial settings to the following default values:  
XOn: 11    BRK: 0  
Xoff: 13    ESC: 0  
EVE: OFF    NSE: OFF  
EVT: 0    RTS: OFF  
ERR: OFF    TXL: FIFO size of hardware  
ERR: 0    FIFO: ON  
BKE: OFF
- Security Settings**  
Choosing this option will restore each port's security settings so that they accept data from any IP address.
- Blue Heat/Net Settings**  
Choosing this option will restore the Blue Heat/Net settings to the following default values:  
Flash Enabled: Yes    Domain Name: blueheat.net  
Boot Enabled: No    Hostname: BHNXXXXXXXX, where XXXXXXXX is the serial number of the unit  
tftp Enabled: No    Gateway IP Address: 0.0.0.0  
Use DHCP: No    Broadcast IP Address: 255.255.255.255  
Configuration Port: Scan All Ports    Subnet Mask: 255.255.255.0  
Session Timeout: 5 minutes    Bootfile Name: BHNuClinux\_X.XX.gz, where X.XX is the original version of the firmware  
Boot Delay: 30 seconds    TCP Port: 49152  
Server IP Address: 0.0.0.0    DNS IP: 0.0.0.0  
Blue Heat/Net IP Address: 192.168.42.1
- System Settings**  
Choosing this option will restore the Blue Heat/Net system settings, such as passwords.  
**Note:** passwords are reset immediately and do not need to be saved to Flash in order to take effect.

Figure 17: Restore Default Settings

### *Saving To Flash*

When you make configuration changes, the changes are stored temporarily in memory. If you reboot your Blue Heat/Net Sync at this point, any configuration changes you made will be lost. To permanently save your changes, you need to save them to flash. In order to do this, click the **Save to Flash** button on the upper right-hand side of the Web Configuration Manager page.

If there are changes that need to be saved, the **Save To Flash** button will be yellow. Click the **Submit** button to permanently save any configuration changes to the flash memory so they will be present when you reboot your Blue Heat/Net.



**Figure 18: Saving To Flash**

If you haven't made any configuration changes, the **Save To Flash** button will remain grey.

## Monitoring Your Blue Heat/Net

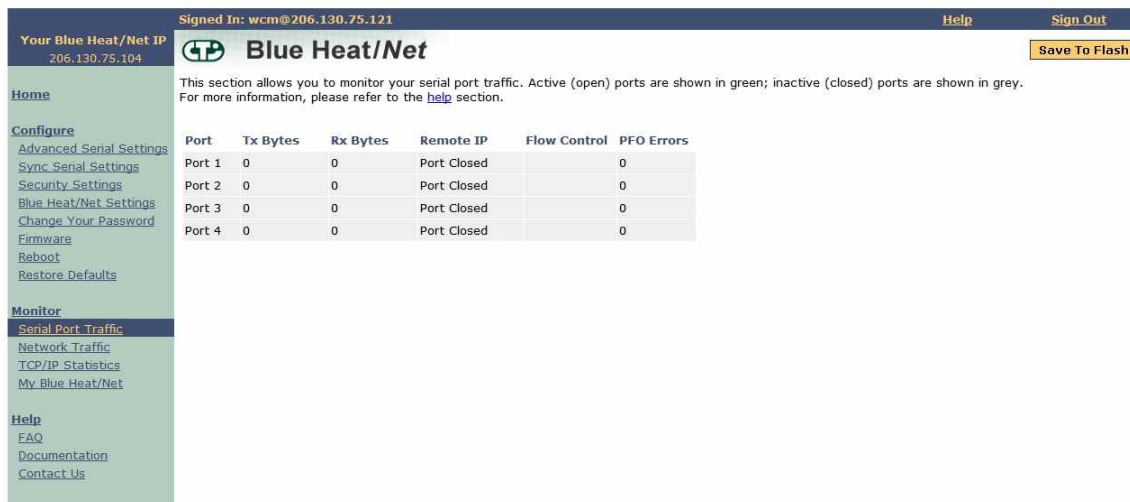
The Blue Heat/Net Sync WCM lets you monitor serial port activity, network traffic and TCP/IP statistics as well as providing hardware and software details for your Blue Heat/Net Sync unit.

### Monitor Serial Port Traffic

This page allows you to monitor your serial port traffic. For each Blue Heat/Net Sync port, you can view the number of bytes transmitted, received, whether the port is using flow control, if there are any Parity/Framing/Overrun errors, and which remote IP address is connected to your serial port.

If ports are active (open) they are shown in green, while inactive (closed) ports are shown in grey.

**NOTE:** This function is not currently operational.



**Figure 19: Monitoring Serial Port Activity**

### Monitor Network Traffic

This page allows you to view all network activity on your Blue Heat/Net. For each active network connection, you can view the local IP address and port, the remote IP address and port, the status of the connection, the protocol being used, as well as the number of queued transmit and receive bytes.

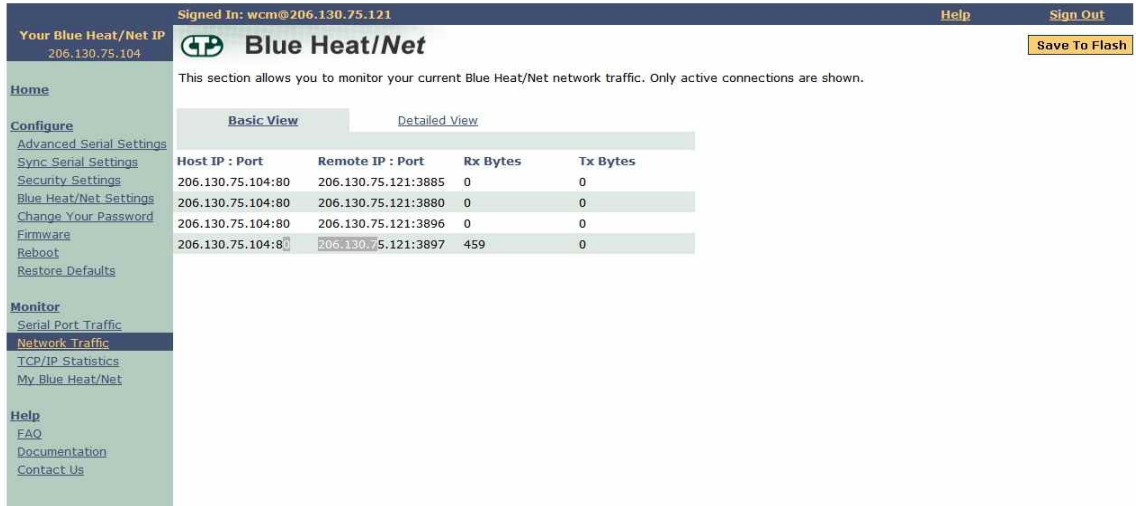


Figure 20: Monitoring Network Traffic

### Monitor TCP/IP Statistics

This page allows you to view TCP, IP, UDP and ICMP statistics for your Blue Heat/Net Sync. This page also has a link which describes each of the network statistic parameters. Simply click on the **Parameter Descriptions** link, and a new window will open up which contains a description of each parameter.

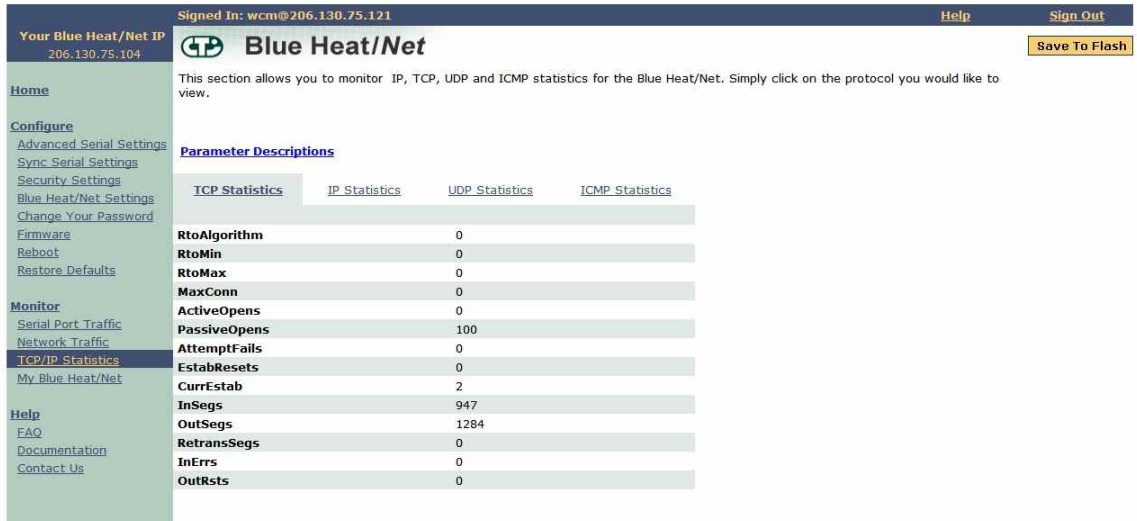


Figure 21: Monitoring TCP/IP Statistics

### My Blue Heat/Net Sync

This page provides you with three display options: Hardware, Software and Performance.

Use this link to find information such as device serial number, runtime software versions and firmware versions.

The screenshot shows the 'My Blue Heat/Net' page with the 'Hardware Details' tab selected. The page header includes the user's IP address (206.130.75.104), the device name 'Blue Heat/Net', and a 'Save To Flash' button. The main content area displays a table of hardware properties.

<b>Product Serial Number</b>	00004569
<b>Product MAC Address</b>	00:0c:8b:00:11:d9
<b>Part Number</b>	BMG006
<b>Description</b>	Blue Heat/Net Sync 4 Port
<b>Port 1 UART Type</b>	Not Available
<b>Port 2 UART Type</b>	Not Available
<b>Port 3 UART Type</b>	Not Available
<b>Port 4 UART Type</b>	Not Available

Figure 22: My Blue Heat/Net Sync Hardware Details

The screenshot shows the 'My Blue Heat/Net' page with the 'Software Details' tab selected. The page header is identical to Figure 22. The main content area displays a table of software versions.

<i>Versions for Runtime Software</i>	
<b>Blue Heat/Net</b>	0.105_syncdjw
<b>uClinux</b>	20020927
<b>linux kernel</b>	2.4.19
<b>serial driver</b>	6.00
<b>libcfg</b>	3.00
<b>libtwcm</b>	1.5
<b>plauncher</b>	0.10
<b>ctid</b>	0.118
<b>bhnconfig</b>	1.00
<b>bhn</b>	dbg
<b>calcnet</b>	0.60
<b>sink</b>	2.60
<b>talk</b>	2.60
<b>login</b>	2.0
<b>wcm</b>	1.2
<b>rawsock</b>	0.001
<b>sample_app</b>	0.00
<b>dprw</b>	
<b>loopback</b>	
<b>pvtest</b>	
<b>readrtc</b>	
<b>writelarm</b>	
<b>writertc</b>	
<b>wrttest</b>	
<i>Versions for Firmware Modules</i>	
<b>Bootloader</b>	V504+C
<b>CDS</b>	V17

Figure 23: My Blue Heat/Net Sync Software Details

## Software Installation for Windows

The Blue Heat/Net Sync is designed for easy installation and set up. This section deals with installing and using the Blue Heat/Net Sync software to communicate with your Blue Heat/Net Sync and its COM ports.

To do so, you will use the CD included with the Blue Heat/Net Sync to install the Configuration Manager on your computer. The Blue Heat/Net Sync Configuration Manager will allow you install the Blue Heat/Net Sync on your local system, and map and configure the Blue Heat/Net Sync's communication ports.

**NOTE:** Software support for Windows is still in development

### Installing the Blue Heat/Net Sync Configuration Manager

The Blue Heat/Net Sync Configuration Manager is a tool to control your Blue Heat/Net Sync from your local Windows operating system. To install the Blue Heat/Net Sync Configuration Manager on your computer, insert the CD provided with your Blue Heat/Net Sync into the disk drive.

You should see this window in your browser:



**Figure 24: Blue Heat/Net Sync Driver/Software Installation CD**

**NOTE:** Windows XP SP2 users should read the SP2 info prior to installing the Configuration Manager

Select View from the Blue Heat/Net Sync software. It will bring you to the following screen. Click Install to begin the Configuration Manager installation. Ensure you choose Open or Run when the File Download window appears and asks if you'd like to open the file or save it to your computer.

**Connect Tech Inc.**  
Industrial Strength Communications

### Blue Heat/Net Software

To install software/drivers for your Blue Heat/Net, please select from the list of available components below.

<b>Windows Configuration Manager</b>	The Windows Configuration Manager allows: - Windows 2000 - Windows XP (32 & 64 Bit) - Windows Server 2003 (32 & 64 Bit) - Windows Vista (32 & 64 Bit) based computers to access the communications ports on your Blue Heat/Net. After clicking <b>Install</b> select <b>Open</b> or <b>Run</b> to start the installation program.	<b>Install</b>
<b>Serial Configuration Manager</b>	The Serial Configuration Manager ( <b>SCM</b> ) allows you to connect to your Blue Heat/Net using a serial port. You can connect to the <b>SCM</b> by using any terminal application, however you can use the provided HyperTerminal shortcut here. For more information on using the <b>SCM</b> please see the Blue Heat/Net manual.  To connect to the <b>SCM</b> using the provided HyperTerminal shortcut:  <ul style="list-style-type: none"> <li>• Connect your Blue Heat/Net to COM1 of your computer using the supplied cable (CB006) and adapter (CB005).</li> <li>• Click <b>Connect</b>. After clicking <b>Connect</b> select <b>Open</b> or <b>Run</b> to open HyperTerminal.</li> </ul> <b>Note:</b> Using the provided HyperTerminal shortcut requires HyperTerminal be installed.	<b>Connect</b>
<b>Linux 2.4 Driver</b>	The Linux driver allows your Linux 2.4 based computers to access the communications ports on your Blue Heat/Net. See the <a href="#">Manuals</a> section for installation instructions.	<b>Get</b>
<b>Linux 2.6 Driver</b>	The Linux driver allows your Linux 2.6 based computers to access the communications ports on your Blue Heat/Net. See the <a href="#">Manuals</a> section for installation instructions.	<b>Get</b>
<b>QNX4 Driver</b>	The QNX4 driver allows your QNX4 based computers to access the communications ports on your Blue Heat/Net. See the <a href="#">Manuals</a> section for installation instructions.	<b>Get</b>
<b>QNX6 Driver</b>	The QNX6 driver allows your QNX6 based computers to access the communications ports on your Blue Heat/Net. See the <a href="#">Manuals</a> section for installation instructions.	<b>Get</b>

**< Back to Main Menu**

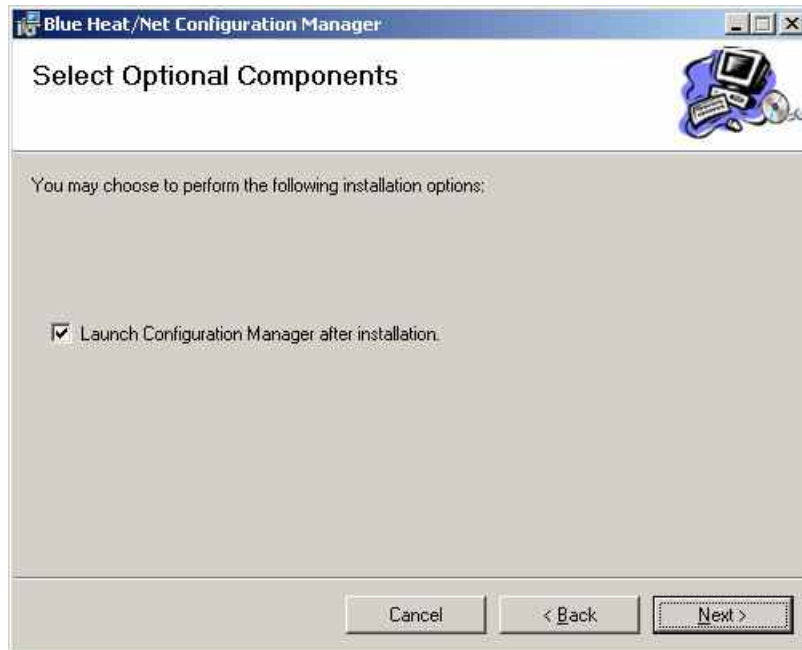
**ISO 9001 CERTIFIED** Copyright © 2008 [Connect Tech Inc.](#) All Rights Reserved.  
<http://www.connecttech.com>

Figure 25: Blue Heat/Net Sync Software Installation Screen

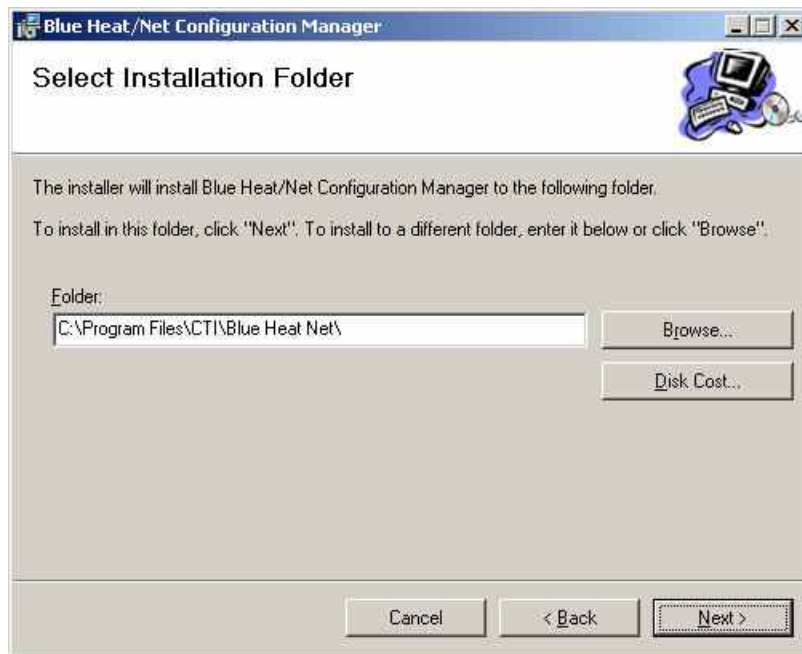
The Blue Heat/Net Configuration Manager Setup Wizard will begin. Click **Next** to start.



Next you will have the option to launch the configuration manager after installation.

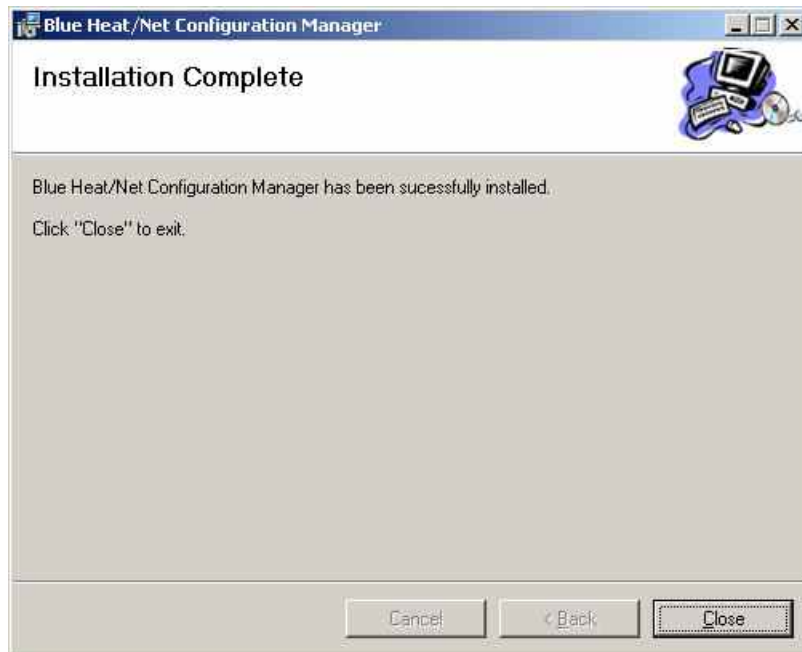


The installer will install the Configuration Manager into **C:\Program Files\CTI\Blue Heat Net**. If you'd prefer an alternate location, specify in the space provided, or click **Browse** to locate the new folder. Click **Next**.



You will then be prompted to confirm you wish to install the Configuration Manager. Select **Next** to begin.

When the Installation Complete window appears, the Configuration Manager has been successfully installed. Click **Close** to exit the installation wizard.



## Running the Configuration Manager

If you chose the option to launch the Blue Heat/Net Sync Configuration Manager after installation, the main Configuration Manager window should now be open on your screen. If you did not, you can launch it from the CTI default folder or whichever folder you chose during the installation.



Figure 26: My Blue Heat/Net Sync Places Screen

## Device Installation

Select **My Blue Heat/Net Sync Places** from the main Configuration window. (NOTE: If there is no Blue Heat/Net Sync installed, you will be prompted to auto discover a Blue Heat/Net Sync on your network. If you choose to do so, click **Yes** and then jump ahead to the [Auto Discover Blue Heat/Net Sync](#) section)

Right-click on **My Blue Heat/Net Sync Places** or click on the **Action** menu to pull up the sub menu options.

There are three ways to install a Blue Heat/Net Sync device: Configure Default Blue Heat/Net Sync, Add New Blue Heat/Net Sync or Auto Discover Blue Heat/Net Sync.



## Configure Default Blue Heat/Net Sync

You can choose this option when your Blue Heat/Net Sync still has a factory default IP address of 192.168.42.1. It will launch the Web Configuration Manager for this IP address, enabling you to configure your Blue Heat/Net Sync as outlined in the [Web Configuration Manager](#).



Figure 27: Add or Auto Discover Blue Heat/Net Sync Menu Screen

## Add New Blue Heat/Net Sync

You can add a Blue Heat/Net Sync by specifying its IP address or MAC address.

If you specify an IP address, the Configuration Manager will connect to that specific Blue Heat/Net Sync and the configuration information for installation. If it cannot connect, it will not install the unit. The Blue Heat/Net Sync may get the IP address from DHCP server or it can be manually fixed. The Configuration Manager will use 49152 as the default TCP port. This value is configurable.

If you specify a MAC address (located on the underside of the device), the Configuration Manager will use the auto-discover mechanism to retrieve the information for installation. The auto-discover mechanism uses UDP broadcast, so the unit must be located on the local network to install via MAC address. The Configuration Manager will use 49152 as the default UDP port. This value is configurable.

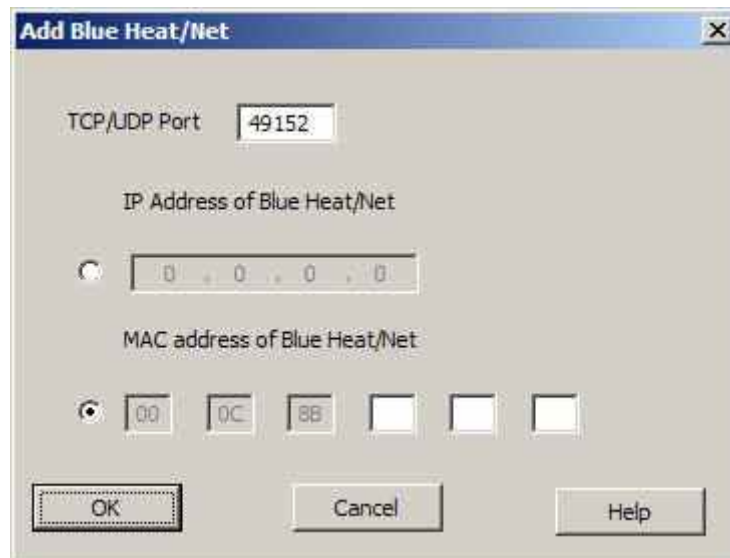


Figure 28: Add Blue Heat/Net Sync Screen

## Auto Discover Blue Heat/Net Sync

The auto discover will broadcast a message to all the Blue Heat/Net Sync devices on your network. Upon receiving the broadcast packet, the Blue Heat/Net Sync device will respond. Click the **Auto Discover** button to search for Blue Heat/Net. The searching domain can be changed by checking **Use Specific Broadcast IP** and entering an IP address domain in the IP address box. The broadcast packet will use the default UDP port 49152, but it can be changed in the Blue Heat/Net Sync configuration. The **Stop** button will end the search.

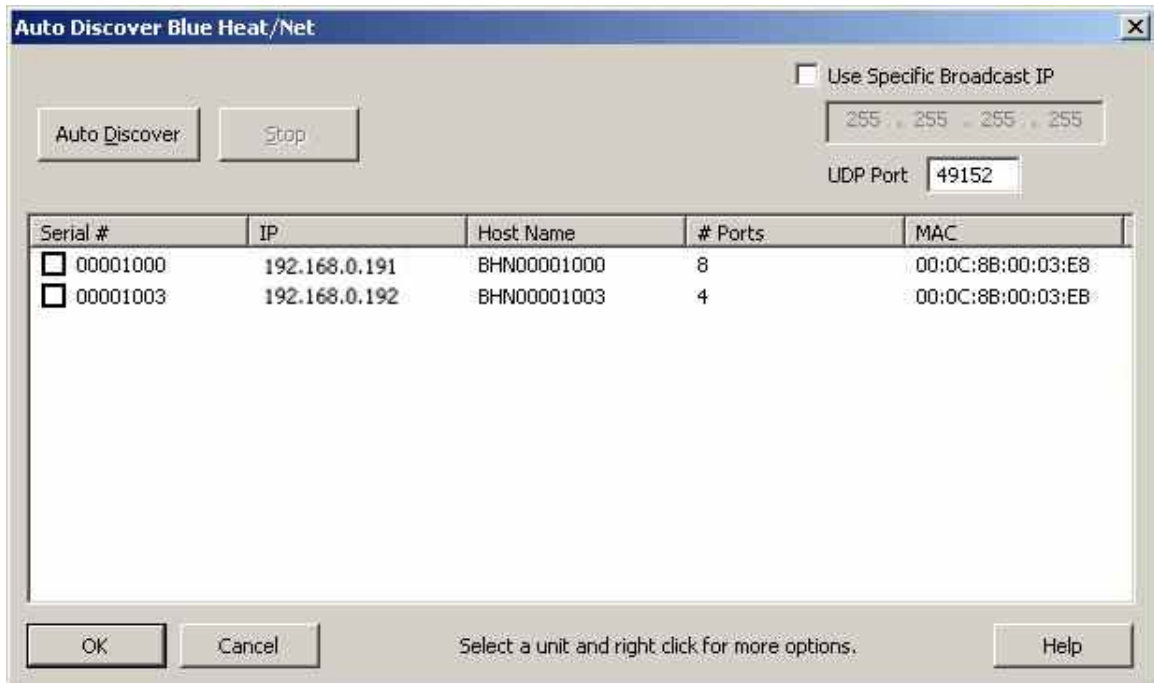


Figure 29: Auto Discover Blue Heat/Net Sync Screen

**Auto Discover** will list any Blue Heat/Net Sync on your network, along with Blue Heat/Net Sync's serial number, IP address, host name, number of available ports and the MAC address. To install a Blue Heat/Net Sync check the appropriate box under **Serial #** column and then click **OK**. Right click for more options, including the option to launch the Web Configuration Manager.

## Configuring the Blue Heat/Net Sync

After the unit is installed the Configuration window will look like this:



**Figure 30: Installed Blue Heat/Net Sync Screen**

You are now ready to map the ports of the Blue Heat/Net Sync.

## Port Mapping

To map the available ports of the Blue Heat/Net Sync, right-click on **Blue Heat/Net #** and then select **Map Port(s)**. You can also select **Action** from the main menu, and choose **Map Port(s)**.

**NOTE:** This function is not currently operational.



Figure 31: Map Port(s) Menu

There are three modes to Map Ports: **Basic**, **Advanced** and **Express**.

### Express

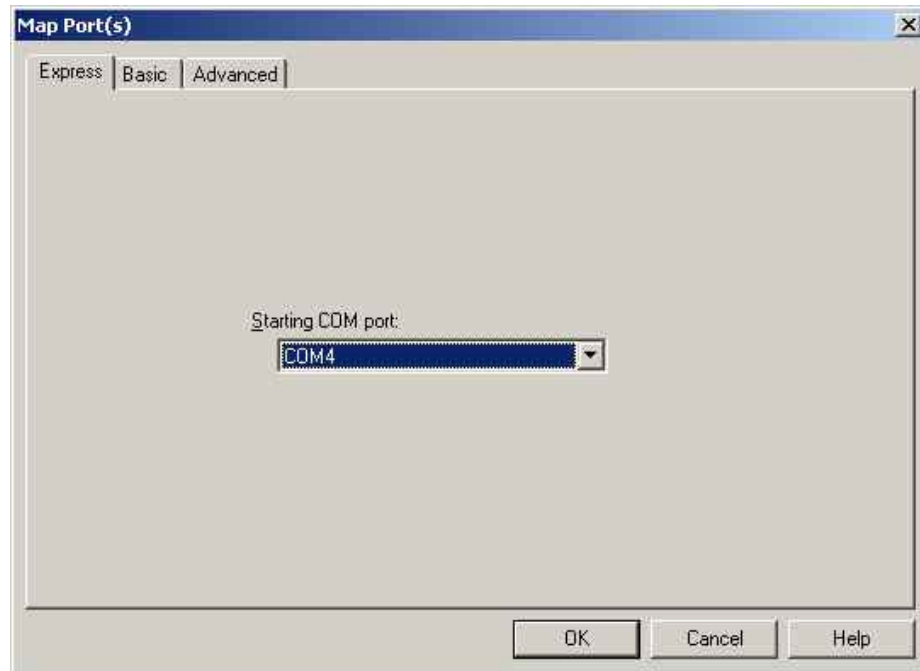


Figure 32: Map Port(s) Express Method Screen

This will install all the available ports of the selected Blue Heat/Net Sync with one click. The list box **Starting COM Port** enables the user to select the starting COM number. If a COM number with **in use** is selected, ensure those ports are not attached to a device by going to My Computer -> Control Panel -> System -> Hardware -> Device Manager -> Ports (COM & LPT).

During the course of port mapping, the **Found New Hardware Wizard** will appear as follows:



**Figure 33: Found New Hardware Wizard**

Select **No, not at this time**. Click **Next**. If you are running Windows 2000 this wizard will not appear.

The following window will appear:

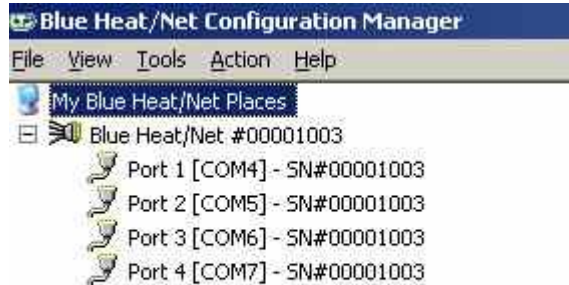


At this point a Software Installation window will appear. Select **Install the software automatically (Recommended)** to proceed.

Click **Next**.

If there are more ports to map, the **Found New Hardware Wizard** will appear again. Repeat the procedure above until all the ports are mapped.

The ports are now mapped, and the Configuration Manager window should appear similar to the one below.



**Figure 34: Configuration Manager Window after Successfully Mapping Ports**

**Basic**



**Figure 35: Basic Port Mapping Option**

The Basic option installs all the available ports of the selected Blue Heat/Net Sync, one port at a time. It has two list boxes, **Blue Heat/Net Sync Port** and **Local COM Port**.

**Blue Heat/Net Sync Port:**

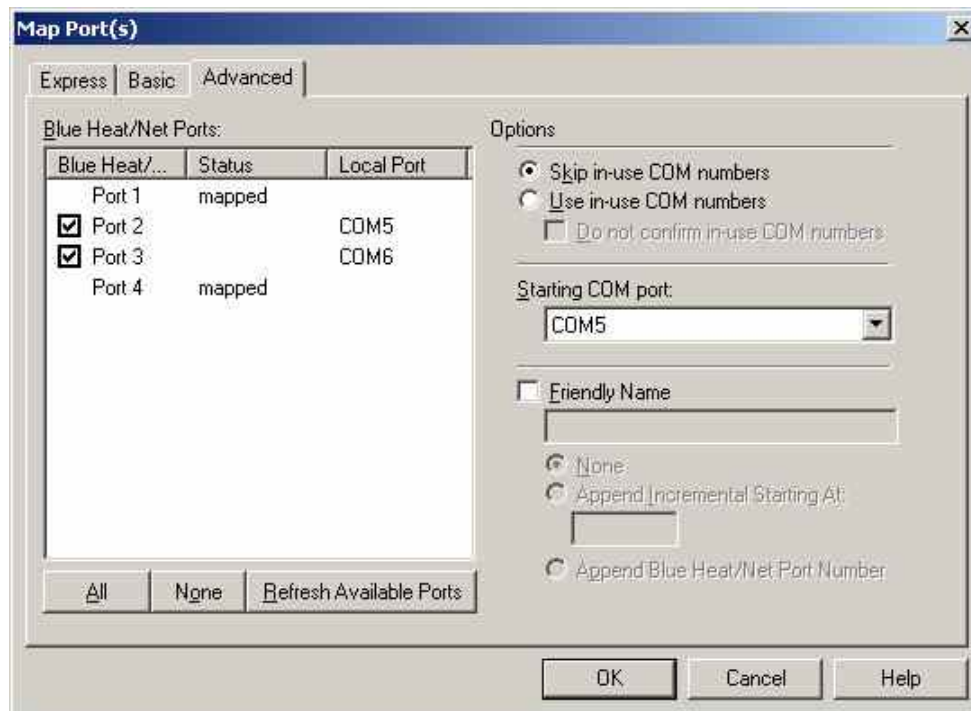
This refers to the physical COM port on the Blue Heat/Net Sync as labelled on its enclosure. Click **Refresh Available Ports** to update this list to reflect the current status.

**Local COM Port:**

This is local COM number that the OS application will use. It is the virtual COM port equivalent of the remote COM port. It is also the starting COM number for the first remote port. If a COM number with 'in use' is selected then ensure those ports are not attached to a device by going to My Computer -> Control Panel -> System -> Hardware -> Device Manager -> Ports (COM & LPT).

**Friendly Name:**

You can choose to add a name to the port description. This is an optional feature that adds a personalized string to the description of the port in the main display window. Choose the appropriate Blue Heat/Net Sync port and a corresponding local COM number in the list menus, and enter a Friendly Name, if desired, and click **OK**. The [Found New Hardware Wizard](#) will appear. See instructions above for remainder of setup process.

**Advanced**

**Figure 36: Advanced Port Mapping Interface**

This is an advanced interface for mapping ports. It will show all remote ports available for mapping as follows:

It has three columns, **Blue Heat/Net Sync Port**, **Status** and **Local Port**.

**Blue Heat/Net Sync Port** refers to the physical port on Blue Heat/Net Sync, **Status** refers to whether the port is mapped or not and **Local Port** refers to the possible COM numbers that the Win32 application will use. The above example shows that the selected Blue Heat/Net Sync has two available ports to map, and that Ports 1 and 4 are already mapped.

Click **None** to deselect all **Blue Heat/Net Sync Port** selections and none will be mapped. An individual Remote Port can be mapped by marking the corresponding check box. Clicking **All**

will select all Blue Heat/Net Sync Ports for mapping. **Refresh Available Ports** will refresh this list.

The Advanced window offers the following choice under Options:

Skip in-use COM numbers

Use in-use COM numbers.

This is related to the local COM number for the mapped ports. Sometimes, COM numbers can be occupied in the operating system's COM number database even though they are not attached to any device. If **Skip in-use COM numbers** is selected during mapping, then those occupied COM numbers will be passed over and the next free COM number will be used. If **Use in-use COM numbers** is selected then those occupied COM numbers will be used, with a user warning, during mapping. If **Do not confirm in-use COM numbers** is checked then no warning will be issued. Be extra careful when selecting **Use in-use COM numbers** since it will conflict if any device is attached to that occupied COM number. To find out if a device is attached to that COM number go to My Computer -> Control Panel -> System -> Hardware -> Device Manager -> Ports (COM & LPT).

**Starting COM port:** This enables you to change the starting COM number for mapping.

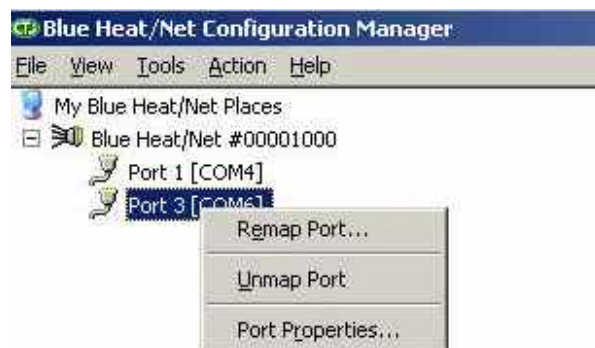
If a COM number with [in use] is selected, ensure those ports are not attached to any device by going to My Computer -> Control Panel -> System -> Hardware -> Device Manager -> Ports (COM & LPT).

**Friendly Name** is an optional feature that enables the user to edit a string to be appended to the port description of My Computer -> Control Panel -> System -> Hardware -> Device Manager -> Ports (COM & LPT). Selecting **Append Incremental Starting At:** will append the number entered for that edit box to the entered **Friendly Name** string, this number will be incremented for multiple port mappings checked in the **Blue Heat/Net Sync Port** list. Selecting **Append Remote Port Number** will append the remote port number to the string entered in the edit box.

For each port installed, the [Found New Hardware Wizard](#) will appear.

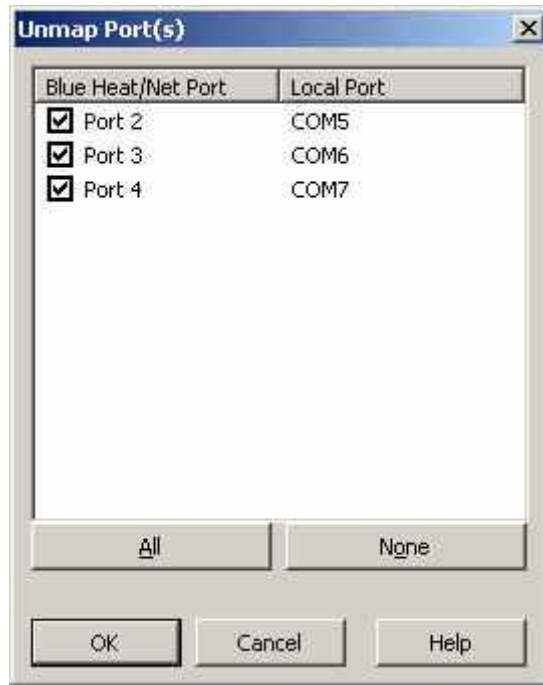
## Unmap Port(s):

This option is located under the Action menu item when the Blue Heat/Net Sync unit is selected, or an individual port is selected. . It is also available by right-clicking on the selected Blue Heat/Net Sync unit or port.



**Figure 37: Port Action Menu**

If you choose to unmap a local COM port while selecting a port, a dialogue box will prompt you to be sure you wish to unmap the port.



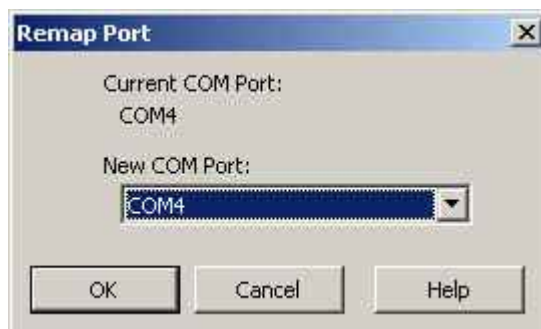
**Figure 38: Unmap Port Window**

If you choose Unmap Port while the Blue Heat/Net Sync unit is selected, you will see a list of ports.

**Blue Heat/Net Sync Port** refers to the port on the Blue Heat/Net Sync and **Local Port** refers to the corresponding COM port on the computer for Win32 applications. **All** will select all ports of the selected unit to be unmapped, **None** will deselect all ports. Individual ports can be selected by checking the respective port under the **Blue Heat/Net Sync Port** column.

## Remapping Ports

Select the installed port you wish to remap, and then either go to the **Action** menu or right-click. Choose **Remap Port**. A dialogue box will display the current COM port, and ask you to input the new COM port from a drop down menu. Select the new COM port and click **OK**

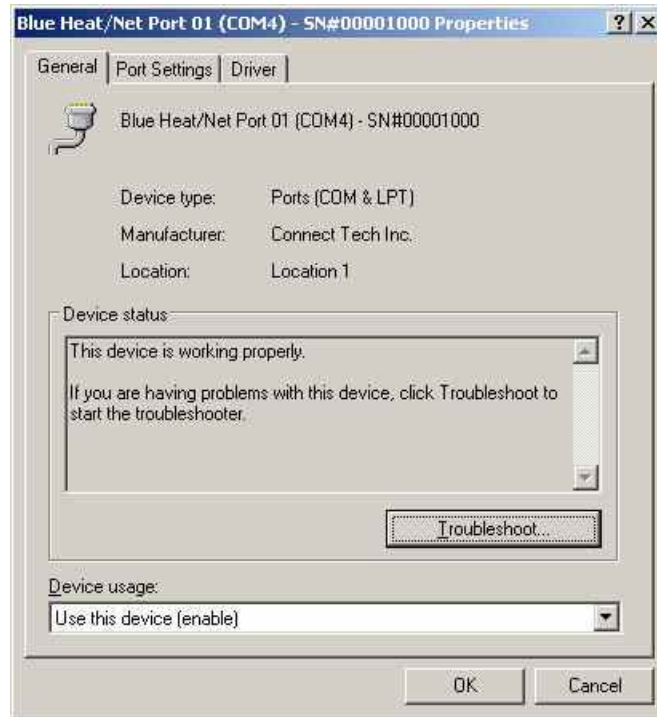


**Figure 39: Remap Port Window**

## Port Properties

Right-click on the port you wish to observe, and choose **Port Properties**. A window will open with three tabs: **General**, **Port Settings** and **Driver**.

The **General** properties include port and COM number, serial number, device type, manufacturer and location.



**Figure 40: Port Properties Window**

The **Port Settings** tab gives the user access to the basic port setting options: Bits per second, Data bits, Parity, Stop bits and Flow control. There is also an option to reset all port settings to their default settings.

## Advanced Settings

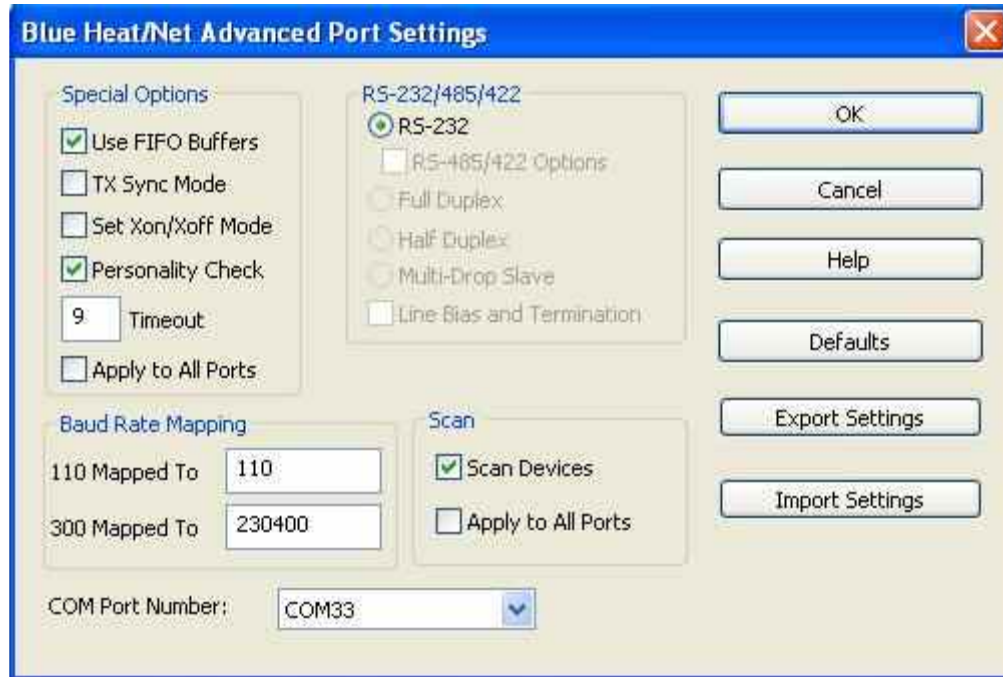


Figure 41: Advanced Settings Window

### Special Options

With the exception of Use FIFO Buffers, these options are typically left unselected. They are provided to maintain compatibility with applications that require strict synchronization between the Blue Heat/Net Sync and the application. Some degradation of throughput will occur when these options are selected.

- **Use FIFO Buffers** (default is selected)  
The Blue Heat/Net Sync makes use of UARTs with configurable FIFOs. Selecting or deselecting this option will enable or disable FIFO buffers of the UART respectively.
- **Tx Sync Mode** (default is unselected)  
In this mode data will not be marked as sent until the Blue Heat/Net Sync has actually sent the data. This allows for tight synchronization between the application and the data transmission. Data is reported as soon as it is sent to the Blue Heat/Net Sync when this mode is **not** turned on. Leaving this mode unselected improves throughput.
- **Set Xon/Xoff Mode** (default is unselected)  
This mode must be turned on if EscapeCommFunction(SETXON\XOFF) is used by the application connecting to the Blue Heat/Net Sync port. This allows the Blue Heat/Net Sync to keep the flow control state synchronized with these IOCTLs. It is best to leave this option unselected if this specific EscapeCommFunction(SETXON\XOFF) is not used, because the extra work needed to maintain the flow state slows communications down.
- **Apply to All Ports** (default is unselected)  
This will apply the above two settings to all ports of the same Blue Heat/Net Sync box.
- **Timeout** (default is 9)  
This option sets the protocol timeout between the host driver and Blue Heat/Net Sync firmware. For some networks this value may need to be modified for better operation. A higher value will provide a longer time for the host driver to wait for a response from the Blue Heat/Net Sync unit. The default value is 9 seconds and works well for most network setups.

- **Personality Check** (default is selected)  
In this mode the port will check whether the corresponding port of Blue Heat/Net Sync is in the proper mode before opening the port. When selected the open request will fail if the mode is different then the open request by the application will be denied. This check avoids unexpected results when opening ports that might have their personalities changed. Ports will respond faster if it is unselected.

### **Line Interface modes**

The following line interface modes can be selected:

- RS-232 (V.28)
- V.35
- EIA-530
- EIA-530A
- RS-449 (V.36)
- X.21 (V.11)

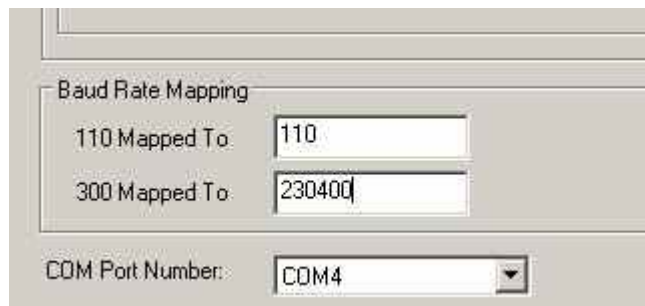
### **Options for EIA-530, EIA-530A, RS-449, X.21**

This option is checked to access the following duplex options:

- **Full Duplex** (default)  
In this mode TxD & RxD are active all the time. This mode is typically used in point-to-point situations much like RS-232. RTS and CTS can be used along with the data signals.
- **Half Duplex**  
In this mode the TxD line driver is only enabled when data is transmitted, and RxD is disabled when data is being transmitted. This mode is typically used in either point-to-point "two wire" connections OR in multi-drop "two wire" bussed connections. CTS and RTS are not usually used with this configuration.
- **Multi-Drop Slave**  
In this mode the TxD line driver is only enabled when data is transmitted and RxD is enabled all the time. This mode is typically used in multi-drop "four wire" connections. RTS and CTS are not usually used in this configuration.
- **Line Bias and Termination**  
This enables the line and bias termination.

### **Baud Rate Mapping**

In some applications, high or unusual baud rates such as 230400 bps cannot be specified directly. For such situations, two baud rates (110 bps and 300 bps) are provided which can be mapped to different values if necessary.



**Figure 42: Baud Rate Mapping Options**

By default 300 baud is mapped to 230400 baud. In this case, an actual baud rate of 230400 will be set when 300 baud is specified.

If baud rate mapping is not desired, specify the same baud rate in the edit box beside each of the selections. For example 300 would be set to 300 and 110 would be set to 110.

### **COM Port Number**

The Blue Heat/Net Sync driver supports the ability to change COM port names, also referred to as COM port mapping. Use this combo box to change the COM port number to be used for the current port. For example specifying COM5 would set the COM name for this port to COM5.

*Ensure the COM name selected is not already in use or the port may not respond properly.*

### **Scan**

- **Scan Devices** (default is selected)  
In this mode, the OS will scan devices attached to ports and install them during reboot or when the driver restarts. In some situations, the OS will install a serial mouse device when data is being received at the ports during reboot or restart of the driver. In that case, uncheck so that OS will not install phantom devices.
- **Apply to All Ports**  
This will apply the above setting to all ports of the same Blue Heat/Net Sync box.

### **Defaults Button**

The defaults button resets the current settings for all options on the Advanced Settings dialogue box to the default settings (With the exception of the COM Port Number).

### **Export Settings**

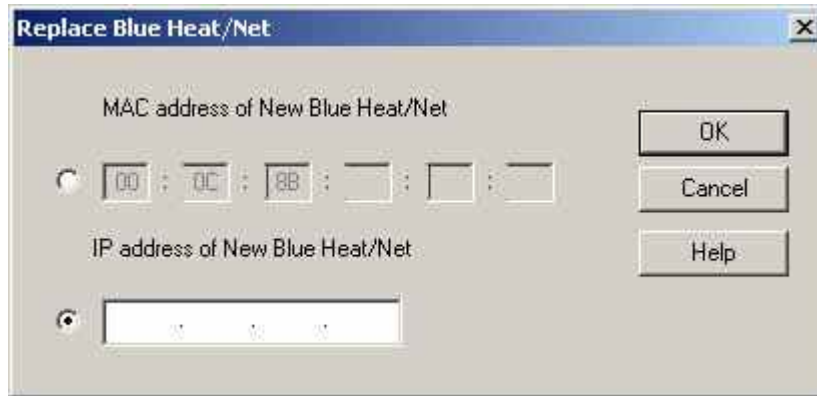
This will save the existing settings to an XML file.

### **Import Settings**

This will load settings from an XML file. Choose **Apply to All Ports** if the settings are to be applied to all ports. The new settings will take effect after clicking **OK**.

### **Replacing your Blue Heat/Net Sync:**

This option is located under the Action menu when the Blue Heat/Net Sync unit is selected. It is used if you need to replace the selected Blue Heat/Net Sync with another Blue Heat/Net Sync. You must have the new unit's MAC address or IP address, as you will be prompted to supply one of these parameters. The **Replace Blue Heat/Net Sync** is helpful if a unit needs to be replaced with a identical one, for whatever reason. (If the new unit's hostname is changed to be exactly the same as the replaced unit, it will not be necessary to follow this procedure. The driver will automatically replace the unit).



**Figure 43: Replace Blue Heat/Net Sync Window**

### **Removing your Blue Heat/Net Sync:**

Selecting **Remove Blue Heat/Net Sync** in the Action menu will remove the Blue Heat/Net Sync device you have selected from your system. To remove more than one Blue Heat/Net Sync at a time, select **My Blue Heat/Net Sync Places**, and either right-click or choose **Action** from the menu, and select **Remove All Blue Heat/Net**. This will remove all Blue Heat/Net Syncs located on your system.

### **Blue Heat/Net Sync Properties:**

This provides information about the Blue Heat/Net Sync you have selected. It includes Host name, MAC address, IP Address, Serial No., CDS Version, uClinux Version, Boot Loader Version, and the Number of Ports on your Blue Heat/Net Sync.

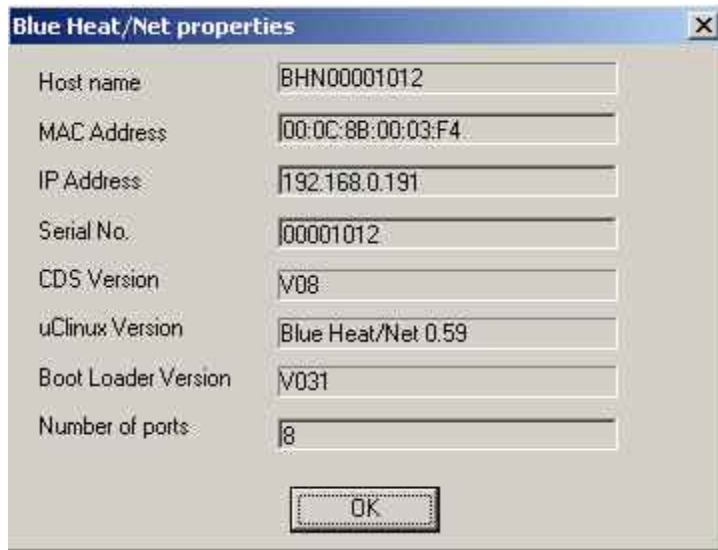


Figure 44: Blue Heat/Net Sync Properties

### Driver Removal

Located under the **Tools** menu, choosing **Remove Drivers** while the Blue Heat/Net Sync unit is selected will remove the drivers for units on your system. A warning box will appear to ensure you wish to continue. Click **OK** to remove all Blue Heat/Net Sync device drivers.

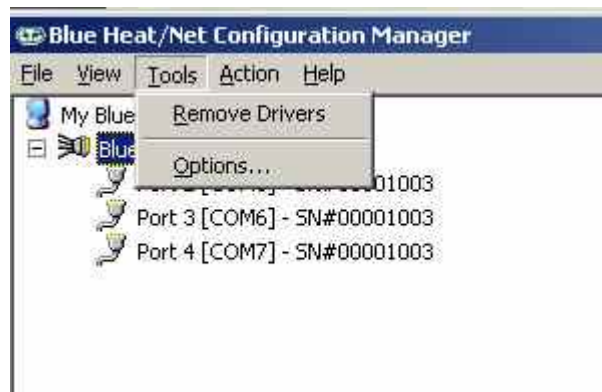


Figure 45: Remove Drivers Window

## Software Installation for Linux

### Installing the Linux Host Driver

**NOTE:** Software support for Linux is still in development

Configure your Blue Heat/Net Sync prior to installing your Linux driver, as outlined in the [Blue Heat/Net Sync Configuration](#) section of this manual. Once you have your Blue Heat/Net Sync configured, connect the Blue Heat/Net Sync to the network and make sure you can communicate with the unit.

If it is connected, but you can't communicate with the Blue Heat/Net, try using the [SCM Command Reference](#) (Serial Configuration Manager) to reconfigure the network settings.

Set the line modes of each port (232, 485-HD, 485-FD, etc). This step is vital if your Blue Heat/Net Sync is to operate correctly within the Linux Operating System. You can configure the line modes using any of the configuration managers. Reboot your Blue Heat/Net Sync and ping the unit.

The Linux driver is available on the CD that shipped with your Blue Heat/Net. The latest version of the Linux driver is also available for download from the Connect Tech website.

Insert the CD provided with your Blue Heat/Net Sync into the disk drive. Follow the steps below to install the driver.

1. Log in as root.
2. Mount your CD drive (where XX is your CD ROM drive location).  
**mount /dev/hdxx/mnt/cdrom**
3. Copy the driver to your home directory.  
**cp /mnt/cdrom/bh-net/Linux/\*.gz**
4. Change the directory to your home.  
**cd**
5. Unzip the given .tar.gz file into a temporary directory.  
**tar -xvzf BHN\_LHD.tar.gz**
6. Navigate to the temporary directory.  
**cd BHN\_LHD**
7. Run the install script and follow the on-screen instructions.  
**./BHN\_LHD-install.sh**

### Linux Host Driver Setup Using Auto Discovery

1. Navigate to the install directory.  
**cd /usr/cti/BHN-Linux**
2. Create a configuration file.  
**cat /proc/bhn/autodiscover > ./bhn.conf**
3. Run blood.  
**./blood**  
This will attach the driver to **/dev** nodes according to **./bhn.conf**

To test the installation, run a local loopback test between two ports using a standard serial terminal program (like minicom) and a null modem cable.

You should now have a set of Blue Heat/Net Sync ports available as **/dev/bhnS\***. The file **bhn.conf** is used to set the serial port mappings. For more information on serial port mapping in Linux, please refer to the **Readme.txt** located on the Blue Heat/Net Sync CD.

## Firmware Upgrades

If you need to re-install your current firmware, it is located in the firmware directory of the CD you received with your Blue Heat/Net Sync.

Newer firmware versions are available from Connect Tech's website, <http://www.connecttech.com/asp/Support/DownloadZone.asp>. Choose Blue Heat/Net Sync product. Ensure the following parameters are set: **mip**, **sip**, **gip** and **dns\_ip** using the SCM. To upgrade your Blue Heat/Net Sync firmware, you can use any of the following three methods, depending on your preference.

### **Upgrade using WCM (Web Configuration Manager)**

The Web Configuration Manager is the easiest way to upgrade your firmware. Simply log onto the WCM as described in the [WCM \(Web Configuration Manager\)](#) section, and click on the Firmware link on the left menu. This will bring you to the Firmware page. You will have the option to upgrade from the remote CTI website, or to download the upgrade from a local FTP server.

If you choose to upgrade via a local FTP server, copy the firmware (\*.tar) file to the anonymous directory of a local FTP server. If you do not have a local FTP server, contact your system administrator to set one up.

### **Upgrade using SCM (Serial Configuration Manager)**

The SCM method of upgrading is used when the Blue Heat/Net Sync does not boot properly. You can reinstall your original firmware from the supplied CD, or you can download any newer versions that exist from the CTI website in the <http://www.connecttech.com/asp/Support/DownloadZone.asp> or go directly to the FTP site as indicated below.

You will need the use of a TFTP server. (Contact your system administrator to obtain access to a TFTP server). Download the most recent firmware components from the FTP site <ftp://ftp.connecttech.com/pub/BHN/>. These files include **BHNUlinux\_X.XX.gz**, **BHNloader\_VXXX.gz** and **BHNjffs2\_X.XX.gz**.

These files contain all of the Blue Heat/Net Sync firmware. Follow the **update** command instructions for the [SCM Command Reference](#) to update each component.

## Software Development

### Hardware Information

The information provided in this section will offer data pertaining to the hardware components present within the Blue Heat/Net Sync unit. Hardware information documentation will encompass hardware resources, base address map, memory map and table, as well as, PLD registers.

### Hardware Resources

The hardware resources available for use in software development for the Blue Heat/Net Sync, include; chip selects, interrupts, ColdFire MCF5272 GPIO.

#### Chip Selects

Chip Select *	Usage	Data Bus Width	Address Range	Cycle Termination
/CS0	This chip select is used to boot the CPU from the Flash. The Flash is 8M Byte in size.	16 bits	0xFE00 0000 – 0xFE80 0000  8 Mbytes	- Internal WS logic. - 5 wait states.
/CS1	Used to select the IUSCs and the internal PLD registers.	16 bits	0x4000 0000 – 0x4000 2000  8 kbytes	External /TA signal
/CS2	Dual Ported RAM. 32k Bytes total size	16 bits	0x8000 0000 – 0x8000 8000  32 kbytes	External /TA signal
/CS2	Undefined. For future expansion or debugging purposes. Available on debug header P11 on page 8 of Schematic	Undefined, but could be 8 or 16 bits	Undefined.	Undefined.
/CS7	Used for SDRAM. The SDRAM is 16M Bytes in size.	32 bits	0x0000 0000- 0x0100 0000  16 Mbytes	Internal WS logic and SDRAM controller.

**Table 3: Chip Selects**

**Interrupts**

INT *	Usage
/INT1, /INT2	IUSC logically or-ed interrupts. IUSC Interrupts can be muxed to any of the two INTs. One use is to mux all ports configured for Async mode to one IRQ and all ports configured for Sync mode to another interrupt. This should facilitate better software architecture and operation.
/INT3	PLD Interrupt. To support miscellaneous PLD section functions.
/INT6	Ethernet PHY Interrupt. Same PHY as other MCF5272 based Blue Heat/Net models.

\* INTs are active low. Unused interrupts are pulled up to V+.

**Table 4: Interrupts****ColdFire MCF5272 GPIO**

GPIO Bit(s) *	Direction	Usage
PA0 – PA4, PA6	Undefined	Undefined. For future expansion or debugging purposes. Available on debug header P11 on page 8 of Schematic
PA5	Output	CPU Status LED. 1 = LED Off 0 = LED On.
PA8 – PA11	Input	PCB ID. Should be 0x4, for BHN Sync 4 Port.
PA13	Input	Pushbutton input. 1 = not pushed 0 = pushed
PA14	Output	Software forced hardware reset. 1 = Not reset. When setting up this GPIO, be sure to set port to a '1' before changing direction to output. 0 = forces a hardware reset

**Table 5: ColdFire MCF5272 GPIO**

\* All unused GPIO is pulled up with a pullup resistor.

**Base Address Map**

Item	Address Range (hex)
ColdFire MBAR	1000 0000
Internal SRAM (4k Byte)	2000 0000
IUSC 0	4000 0000
IUSC 1	4000 0400
IUSC 2	4000 0800
IUSC 3	4000 0C00
PLD registers	4000 1000
DPR (32k Byte SRAM)	8000 0000
Flash (8 M Byte )	FE00 0000

**Table 6: Base Address Map**



A[5..1] Addresses IUSC registers (see Memory Map Table below).

A[0] Not used explicitly, A0 (along with BS0# and BS1#) select byte size portions of IUSC registers.

**PLD Resource Access:**

A[12] Must be one (1).

A[11..5] Are not used.

A[4..2] Are decoded into selections of internal PLD “registers”.

A4	A3	A2	Function	Notes
0	0	0	Real Time Clock	32 bit read/write (16 bit portions also accessible)
0	0	1	LED Control	16 bit read/write only
0	1	0	Port-1 Line I/F control	16 bit read/write only
0	1	1	Port-2 Line I/F control	16 bit read/write only
1	0	0	Port-3 Line I/F control	16 bit read/write only
1	0	1	Port-4 Line I/F control	16 bit read/write only
1	1	0	Control	16 bit read/write only
1	1	1	Status	16 bit read only

A[1] Is used to select the 16 bit portions of the Real Time Clock register.

A[0] Is not used.

**PLD Memory Map Table**

Address Offset (in hex)	Area (item) Accessed	Register Accessed	Notes
<b>IUSC Area</b>			
<b>IUSC-0</b>			
000	IUSC-0 Sreg [1]	CCAR	
002	IUSC-0 Sreg	CMR	
004	IUSC-0 Sreg	CCSR	
006	IUSC-0 Sreg	CCR	
008	IUSC-0 Sreg	PSR	
00A	IUSC-0 Sreg	PCR	
00C	IUSC-0 Sreg	TMDR	
00E	IUSC-0 Sreg	TMCR	
010	IUSC-0 Sreg	CMCR	
012	IUSC-0 Sreg	HCR	
014	IUSC-0 Sreg	IVR	
016	IUSC-0 Sreg	IOCR	
018	IUSC-0 Sreg	ICR	
01A	IUSC-0 Sreg	DCCR	
01C	IUSC-0 Sreg	MISR	
01E	IUSC-0 Sreg	SICR	
020	IUSC-0 Sreg	RDR(TDR)	8/16 bit Serial Data (byte/word)

Address Offset (in hex)	Area (item) Accessed	Register Accessed	Notes
			Writes go to the Transmitter FIFO Reads come from the Receiver FIFO
022	IUSC-0 Sreg	RMR	
024	IUSC-0 Sreg	RCSR	
026	IUSC-0 Sreg	RICR	
028	IUSC-0 Sreg	RSR	
02A	IUSC-0 Sreg	RCLR	
02C	IUSC-0 Sreg	RCCR	
02E	IUSC-0 Sreg	TCOR	
030	IUSC-0 Sreg	TDR(RDR)	<b>8/16 bit Serial Data (byte/word)</b> Writes go to the Transmitter FIFO Reads come from the Receiver FIFO
032	IUSC-0 Sreg	TMR	
034	IUSC-0 Sreg	TCSR	
036	IUSC-0 Sreg	TICR	
038	IUSC-0 Sreg	TSR	
03A	IUSC-0 Sreg	TCLR	
03C	IUSC-0 Sreg	TCCR	
03E	IUSC-0 Sreg	TCIR	
040→07F	---	---	Aliases of addresses 00→3F
080->09F	IUSC Data FIFO's (32 bytes)	RDR/TDR	<b>16 bit Serial Data transfers ONLY!!</b> Writes go to the Transmitter FIFO Reads come from the Receiver FIFO (useful for block data movements)
0A0→0FE			Aliases of 080->9F
100	IUSC-0 Dreg [2]	DCAR	
102	IUSC-0 Dreg	TDMR	
104	---	---	Reserved, do not access
106	IUSC-0 Dreg	DCR	
108	IUSC-0 Dreg	DACR	
10A→111	---	---	Reserved, do not access
112	IUSC-0 Dreg	BDCR	
114	IUSC-0 Dreg	DIVR	
116	---	---	Reserved, do not access
118	IUSC-0 Dreg	DICR	
11A	IUSC-0 Dreg	CDIR	
11C	IUSC-0 Dreg	SDIR	
11E	IUSC-0 Dreg	TDIAR	
120→129	---	---	Reserved, do not access
12A	IUSC-0 Dreg	TBCR	
12C	IUSC-0 Dreg	TARL	
12E	IUSC-0 Dreg	TARU	
130→139	---	---	Reserved, do not access
13A	IUSC-0 Dreg	NTBCR	
13C	IUSC-0 Dreg	NTARL	
13E	IUSC-0 Dreg	NTARU	
140→181	---	---	Reserved, do not access
182	IUSC-0 Dreg	RDMR	
184→19D	---	---	Reserved, do not access
19E	IUSC-0 Dreg	RDIAR	

Address Offset (in hex)	Area (item) Accessed	Register Accessed	Notes
1A0→1A9	---	---	Reserved, do not access
1AA	IUSC-0 Dreg	RBCR	
1AC	IUSC-0 Dreg	RARL	
1AE	IUSC-0 Dreg	RARU	
1B0→1B9	---	---	Reserved, do not access
1BA	IUSC-0 Dreg	NRBCR	
1BC	IUSC-0 Dreg	NRARL	
1BE	IUSC-0 Dreg	NRARU	
1C0→1FF	---	---	Reserved, do not access
200	IUSC-0		Interrupt Acknowledge (read only)
202→3FF	IUSC-0		Aliases of 200
<b>IUSC-1</b>			
400→5FF	IUSC-1	As Above	Same registers as addresses 000→1FF
600	IUSC-1		Interrupt Acknowledge (read only)
602-7FF	IUSC-1		Aliases of 600
<b>IUSC-2</b>			
800→9FF	IUSC-2	As Above	Same registers as addresses 000→1FF
A00	IUSC-2		Interrupt Acknowledge (read only)
A02→BFF	IUSC-2	---	Aliases of A00
<b>IUSC-3</b>			
C00→DFF	IUSC-3	As Above	Same registers as addresses 000→1FF
E00	IUSC-3	---	Interrupt Acknowledge (read only)
E02→FFF	IUSC-3	---	Aliases of E00
<b>PLD Area</b>			
			<b>See "PLD Registers" for details.</b>
1000	RTCU		Real Time Clock Upper
1002	RTCL		Real Time Clock Lower
1004	LEDC		LED Control
1006			Alias of 1004
1008	LIFC1		Port-1 Line I/F control
100A			Alias of 1008
100C	LIFC2		Port-2 Line I/F control
100E			Alias of 100C
1010	LIFC3		Port-3 Line I/F control
1012			Alias of 1010
1014	LIFC4		Port-4 Line I/F control
1016			Alias of 1014
1018	PLD_CNTRL		Control Bits
101A			Alias of 1018
101C	PLD_STATUS		Status bits
101E			Alias of 101C
1020→1FFF			Unused

[1] Sreg = Serial Register

[2] Dreg = DMA Register

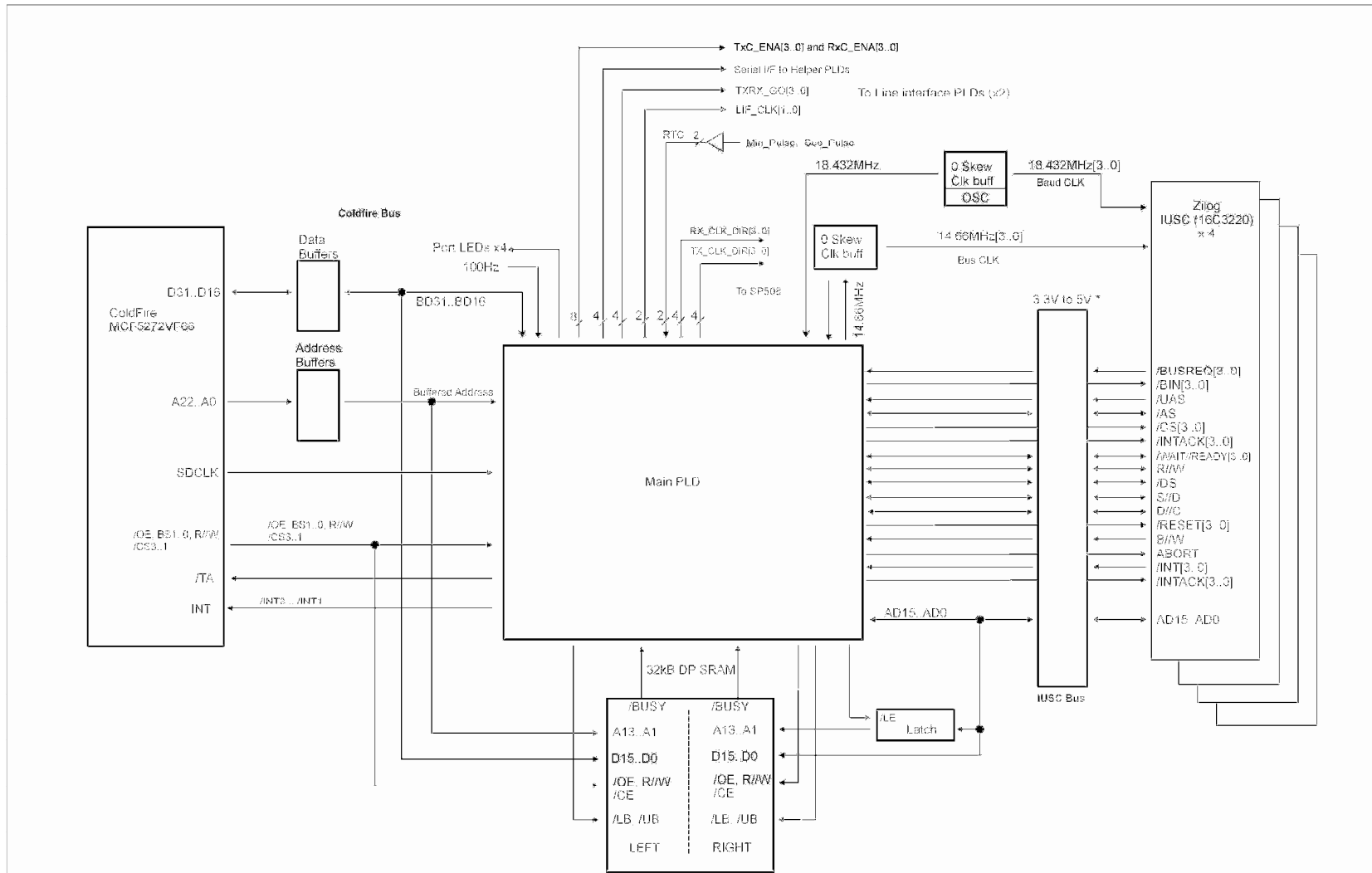
**PLD Registers:**

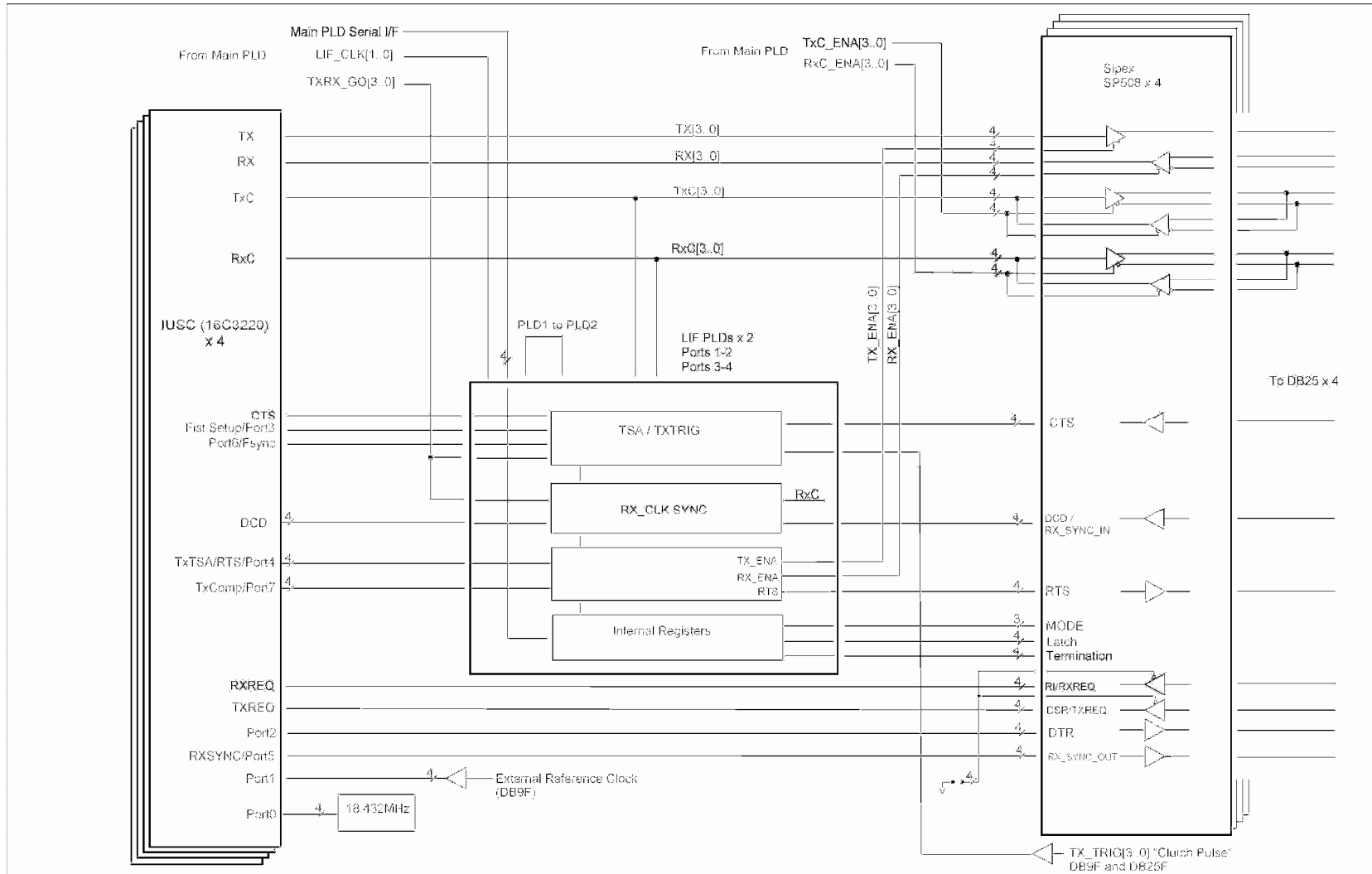
Offset	Reg Name	R/W	Valid Bit	Bit Descriptions	Reset Values (Hex)																																																	
1000	RTCU Real Time Clock Upper	R/W	D15..0	<p>Control Bits: Read/Write only as a 16 Bit word.</p> <table border="1"> <tr> <td>15</td><td>14</td><td>13</td><td>12</td><td>11</td><td>10</td><td>9</td><td>8</td><td>7</td><td>6</td><td>5</td><td>4</td><td>3</td><td>2</td><td>1</td><td>0</td> </tr> <tr> <td>Msk1</td><td>MP</td><td>MPP</td><td>MPO</td><td>IntEN</td><td>SE</td><td>EXT</td><td>ME</td><td>Msk0</td><td>X</td><td>X</td><td>H4</td><td>H3</td><td>H2</td><td>H1</td><td>H0</td> </tr> </table> <p>Msk1: On writes, set this bit to mask bits 14..8. This prevents previous settings of bits 14..8 from being changed.                      MP: <b>Minute Pulse (read only):</b> Current State of Minute-Pulse signal (at the time of the read).                      MPP: <b>Minute Pulse Pending (read only):</b> This bit is set to the same state as the MPO bit (when the MPO bit is written). When the MPO is written high, this bit goes low (=0) when the <b>next</b> selected Minute-Pulse edge occurs.                      MPO: <b>Minute Pulse Once:</b> When low (=0), the selected Minute-Pulse edge always resets the Seconds value. When high (=1) the RTC increment is inhibited, then when the first selected Minute-Pulse edge occurs, the Seconds value will be zeroed, the MPP bit will be cleared and the RTC increment will be enabled. All subsequent Minute-Pulses edges will be ignored.                      IntEN: <b>Clock Interrupt Enable:</b> Enable an interrupt to occur on each clock increment pulse. The Interrupt is cleared by reading (or writing) the RTC Lower Word (the Minutes/Seconds counter) or by disabling the interrupt. There is a dedicated interrupt signal to the Coldfire for the RTC interrupt.                      SE: <b>Seconds-Pulse Edge Select:</b> Selects the edge (of the Seconds-Pulse) which causes the RTC increment, 0=falling, 1=rising.                      EXT: <b>External Time Base Select:</b> 0=Internal Timebase (1 Hz), 1=External Timebase.                      ME: <b>Minute Edge select:</b> Selects the edge (of the Minute-Pulse) which causes the RTC Seconds counter to be reset, 0=falling, 1=rising</p> <p>Msk0: On writes, set this bit to mask bits 6..0. This prevents previous settings of bits 6..0 from being changed.                      H4..0 Hours Setting, or reading (a number between 0 and 23).</p>	15	14	13	12	11	10	9	8	7	6	5	4	3	2	1	0	Msk1	MP	MPP	MPO	IntEN	SE	EXT	ME	Msk0	X	X	H4	H3	H2	H1	H0	0000																	
15	14	13	12	11	10	9	8	7	6	5	4	3	2	1	0																																							
Msk1	MP	MPP	MPO	IntEN	SE	EXT	ME	Msk0	X	X	H4	H3	H2	H1	H0																																							
1002	RTCL Real Time Clock Lower	R/W	D15..0	<p>Control Bits: Read/Write only as a 16 Bit word.</p> <table border="1"> <tr> <td>15</td><td>14</td><td>13</td><td>12</td><td>11</td><td>10</td><td>9</td><td>8</td><td>7</td><td>6</td><td>5</td><td>4</td><td>3</td><td>2</td><td>1</td><td>0</td> </tr> <tr> <td>Msk1</td><td>X</td><td>M5</td><td>M4</td><td>M3</td><td>M2</td><td>M1</td><td>M0</td><td>Msk0</td><td>X</td><td>S5</td><td>S4</td><td>S3</td><td>S2</td><td>S1</td><td>S0</td> </tr> </table> <p>Msk1: On writes, set this bit to mask bits 14..8. This prevents previous settings of bits 14..8 from being changed.                      M5..0: Minute Setting, or reading (a number between 0 and 59)</p> <p>Msk0: On writes, set this bit to mask bits 6..0. This prevents previous settings of bits 6..0 from being changed.                      S5..0 Second Setting, or reading (a number between 0 and 59).</p>	15	14	13	12	11	10	9	8	7	6	5	4	3	2	1	0	Msk1	X	M5	M4	M3	M2	M1	M0	Msk0	X	S5	S4	S3	S2	S1	S0	0000																	
15	14	13	12	11	10	9	8	7	6	5	4	3	2	1	0																																							
Msk1	X	M5	M4	M3	M2	M1	M0	Msk0	X	S5	S4	S3	S2	S1	S0																																							
1004	LEDC LED Control Register	R/W	D15..0	<p>Control Bits: Read/Write only as a 16 Bit word.</p> <table border="1"> <tr> <td></td><td></td><td></td><td></td><td></td><td></td><td></td><td></td><td></td><td colspan="4"><b>Auto Flash Mode</b></td><td colspan="4"><b>Direct Mode</b></td> </tr> <tr> <td>15</td><td>14</td><td>13</td><td>12</td><td>11</td><td>10</td><td>9</td><td>8</td><td>7</td><td>6</td><td>5</td><td>4</td><td>3</td><td>2</td><td>1</td><td>0</td> </tr> <tr> <td>X</td><td>X</td><td>X</td><td>X</td><td>X</td><td>X</td><td>X</td><td>X</td><td>P4</td><td>P3</td><td>P2</td><td>P1</td><td>P4</td><td>P3</td><td>P2</td><td>P1</td> </tr> </table> <p>P4, P4, P2, P1 Port numbers                      Direct Mode: 1= LED on, 0 = LED off                      Auto Flash Mode: 1=LED on for 40ms / off for 40ms, 0=No effect                      X= Don't care, fixed to 0.</p>										<b>Auto Flash Mode</b>				<b>Direct Mode</b>				15	14	13	12	11	10	9	8	7	6	5	4	3	2	1	0	X	X	X	X	X	X	X	X	P4	P3	P2	P1	P4	P3	P2	P1	0000
									<b>Auto Flash Mode</b>				<b>Direct Mode</b>																																									
15	14	13	12	11	10	9	8	7	6	5	4	3	2	1	0																																							
X	X	X	X	X	X	X	X	P4	P3	P2	P1	P4	P3	P2	P1																																							

1008 100C 1010 1014	LIFC1,2,3,4 Line Interface Control	R/W	D15..0	<p>Control Bits: Read/Write only as a 16 Bit word.</p> <table border="1" data-bbox="577 219 1963 284"> <tr> <td>15</td><td>14</td><td>13</td><td>12</td><td>11</td><td>10</td><td>9</td><td>8</td><td>7</td><td>6</td><td>5</td><td>4</td><td>3</td><td>2</td><td>1</td><td>0</td> </tr> <tr> <td>X</td><td>DCDC</td><td>DCDS</td><td>ES</td><td>FSM</td><td>CTSC</td><td>CTSM1</td><td>CTSM0</td><td>RTS</td><td>DC</td><td>42W</td><td>DM</td><td>SPT</td><td>SP2</td><td>SP1</td><td>SP0</td> </tr> </table> <p><b>Important Note:</b> These control bits are transferred to ALL the Line Interface PLD's by a serial interface. On each write to any of the 4 control registers, a serial transfer is started. The transfer takes about 16uS to complete. During this time NO write can occur to <b>any</b> of the 4 registers. A <b>Busy</b> signal is available to indicated that the transfer is in progress. (See the PLD_STATUS Register, below).</p> <p><b>Basic Line Mode Control bits:</b>          SP[2..0] <b>SP508 Line Mode setting bits:</b> See information in SP508 Data sheet. Power-up state=[111].          SPT <b>SP508 Terminator Enable:</b> 0=disable terminator, 1=enable terminator</p> <p><b>Duplex Control and RTS Pin Control bits:</b>          DM <b>Duplex Mode selection:</b> 0=Full, 1=Duplex.          42W <b>4/2 Wire mode selection:</b> 0=2wire (or ½ Duplex), 1=4wire (or Multi-Drop Slave).          DC <b>Duplex Control Source:</b> 0=RTS signal from IUSC, 1=TXComplete signal from IUSC.          RTS <b>RTS Pin Source Selection:</b> 0=RTS signal from IUSC, 1=TXComplete signal from IUSC.          Notes: When Full Duplex mode is selected the "42W" and "DC" bits settings can be changed but are ignored.</p> <p><b>Triggered/Gated Transmission Control Bits</b>          CTSM and FSM</p> <table border="1" data-bbox="598 714 1858 1006"> <thead> <tr> <th>FSM</th> <th>CTSM[1]</th> <th>CTSM[0]</th> <th>FSYNC# pin on IUSC</th> <th>CTS# pin on IUSC</th> </tr> </thead> <tbody> <tr> <td>X</td> <td>0</td> <td>0</td> <td>---</td> <td>Driven from Line Interface CTS signal</td> </tr> <tr> <td>0</td> <td>X</td> <td>X</td> <td>Driven directly from <b>Trigger</b> input signal (inverted)</td> <td>---</td> </tr> <tr> <td>0</td> <td>0</td> <td>1</td> <td>---</td> <td>CTS pulsed low for 15 clock cycles [1] as follows... If CTSC=0: clocked by Transmitter clock. If CTSC=1: clocked by PLD clock (14.66 MHz)</td> </tr> <tr> <td>1</td> <td>0</td> <td>1</td> <td>FSYNC Pulsed for 5 or 1 Transmitter clock cycles [1][2]</td> <td>CTS pulsed low for 5 or 1 Transmitter clock cycles [1][2]</td> </tr> <tr> <td>X</td> <td>1</td> <td>0</td> <td>---</td> <td>CTS is turned ON when appropriate TRG bit is ON (see TRG bits in the PLD_CNTRL register, below)</td> </tr> </tbody> </table> <p>[1] Whenever the appropriate edge of the <b>Trigger</b> input signal occurs.          [2] The choice of 1 or 5 clock cycles is determined by the <b>previous</b> application of the "First Setup" pulse (Port3 of the IUSC device).          The 5 clock period FSYNC/CTS pulse only occurs once on the <b>first</b> Trigger edge, all following Trigger edges produce a 1 clock FSYNC/CTS pulse.</p> <p>CTSC <b>CTS Pulse Clock Source:</b> 1=Internal PLD Clock, 0=Transmitter Clock [TxC]          ES <b>Trigger Edge selection:</b> 0=falling edge, 1=rising edge</p> <p><b>Gated Reception Control Bits</b>          DCDS <b>IUSC DCD Select:</b> 0=Line Interface DCD signal, 1=Driven by the appropriate TRG bit (in the PLD_CNTRL register).          DCDC <b>DCD Clocked:</b> 0=Not clocked, 1=IUSC DCD is synchronized to the falling edge of Rx.C. (Valid for either of the above DCDS selections).</p> <p><b>For Future Use</b>          X Reserved for future use, Set to zero for Writes, zero on Reads</p>	15	14	13	12	11	10	9	8	7	6	5	4	3	2	1	0	X	DCDC	DCDS	ES	FSM	CTSC	CTSM1	CTSM0	RTS	DC	42W	DM	SPT	SP2	SP1	SP0	FSM	CTSM[1]	CTSM[0]	FSYNC# pin on IUSC	CTS# pin on IUSC	X	0	0	---	Driven from Line Interface CTS signal	0	X	X	Driven directly from <b>Trigger</b> input signal (inverted)	---	0	0	1	---	CTS pulsed low for 15 clock cycles [1] as follows... If CTSC=0: clocked by Transmitter clock. If CTSC=1: clocked by PLD clock (14.66 MHz)	1	0	1	FSYNC Pulsed for 5 or 1 Transmitter clock cycles [1][2]	CTS pulsed low for 5 or 1 Transmitter clock cycles [1][2]	X	1	0	---	CTS is turned ON when appropriate TRG bit is ON (see TRG bits in the PLD_CNTRL register, below)	0007
15	14	13	12	11	10	9	8	7	6	5	4	3	2	1	0																																																				
X	DCDC	DCDS	ES	FSM	CTSC	CTSM1	CTSM0	RTS	DC	42W	DM	SPT	SP2	SP1	SP0																																																				
FSM	CTSM[1]	CTSM[0]	FSYNC# pin on IUSC	CTS# pin on IUSC																																																															
X	0	0	---	Driven from Line Interface CTS signal																																																															
0	X	X	Driven directly from <b>Trigger</b> input signal (inverted)	---																																																															
0	0	1	---	CTS pulsed low for 15 clock cycles [1] as follows... If CTSC=0: clocked by Transmitter clock. If CTSC=1: clocked by PLD clock (14.66 MHz)																																																															
1	0	1	FSYNC Pulsed for 5 or 1 Transmitter clock cycles [1][2]	CTS pulsed low for 5 or 1 Transmitter clock cycles [1][2]																																																															
X	1	0	---	CTS is turned ON when appropriate TRG bit is ON (see TRG bits in the PLD_CNTRL register, below)																																																															

1018	PLD_CNTRL Control Bits	R/W	D15..0	<p>Control Bits: Read/Write only as a 16 Bit word.</p> <table border="1" data-bbox="590 224 1892 277"> <tr> <td>15</td><td>14</td><td>13</td><td>12</td><td>11</td><td>10</td><td>9</td><td>8</td><td>7</td><td>6</td><td>5</td><td>4</td><td>3</td><td>2</td><td>1</td><td>0</td> </tr> <tr> <td>IM[3]</td><td>IM[2]</td><td>IM[1]</td><td>IM[0]</td><td>TRG[3]</td><td>TRG[2]</td><td>TRG[1]</td><td>TRG[0]</td><td>X</td><td>X</td><td>IABT</td><td>SMIE</td><td>SR[3]</td><td>SR[2]</td><td>SR[1]</td><td>SR[0]</td> </tr> </table> <p>SR[3..0] <b>IUSC Software Reset:</b> SR[0]=Port1... SR[3]=Port4. Reset is asserted while bit is set to 1. Also, the "Line Interface Control"bits for the given Port, are set back to their power-up state.</p> <p>SMIE <b>Serial Master Interrupt Enable:</b> This bit will enable all IUSC interrupts. If the SMIE bit is turned OFF, the Serial interrupt signal to the Coldfire are turned off, but the Interrupts Status bits remain valid.</p> <p>IABT <b>IUSC DMA operation Abort:</b> Setting this bit will abort any DMA transfer underway, and is mainly used to abruptly stop autonomous IUSC operations.</p> <p>TRG[3..0] <b>TXRX GO:</b> Used to enable the Transmission and Receiver via a hardware signal. These bits cause the CTS and the DCD signal to go ON. (See the CTSM[] and DCDS bits above).</p> <p>IM[3..0] <b>Map IUSC Interrupts:</b> to Coldfire Interrupts. IM[p]=0 selects Interrupt-1, IM[p]=1 selects Interrupt-2. Where [p] is the port number (0to3).</p> <p><b>Interrupt Information</b> All the IUSC interrupts are "gated" together and are presented on Coldfire External Interrupt pin #1 or pin #2 (as selected by the IM bits). All other interrupts (only the Real-Time Clock at this time) are presented to the Coldfire External Interrupt pin #3.</p> <p><b>For Future Use</b> X Reserved for future use, Set to zero for Writes, zero on Reads</p>	15	14	13	12	11	10	9	8	7	6	5	4	3	2	1	0	IM[3]	IM[2]	IM[1]	IM[0]	TRG[3]	TRG[2]	TRG[1]	TRG[0]	X	X	IABT	SMIE	SR[3]	SR[2]	SR[1]	SR[0]	0000
15	14	13	12	11	10	9	8	7	6	5	4	3	2	1	0																						
IM[3]	IM[2]	IM[1]	IM[0]	TRG[3]	TRG[2]	TRG[1]	TRG[0]	X	X	IABT	SMIE	SR[3]	SR[2]	SR[1]	SR[0]																						
101C	PLD_STATUS Status Bits	Read Only	D15..0	<p>Control Bits: Read only as a 16 bit word.</p> <table border="1" data-bbox="590 738 1892 792"> <tr> <td>15</td><td>14</td><td>13</td><td>12</td><td>11</td><td>10</td><td>9</td><td>8</td><td>7</td><td>6</td><td>5</td><td>4</td><td>3</td><td>2</td><td>1</td><td>0</td> </tr> <tr> <td>Busy</td><td>PBL</td><td>Rev[2]</td><td>Rev[1]</td><td>Rev[0]</td><td>ID[1]</td><td>ID[0]</td><td>RIS</td><td>IS2[3]</td><td>IS2[2]</td><td>IS2[1]</td><td>IS2[0]</td><td>IS1[3]</td><td>IS1[2]</td><td>IS1[1]</td><td>IS1[0]</td> </tr> </table> <p>IS1[3..0] <b>Interrupt Status (Interrupt-1):</b> IS1[p]=1 ≡ Interrupt active. Where [p] is the port number (0to3).</p> <p>IS2[3..0] <b>Interrupt Status (Interrupt-2):</b> IS2[p]=1 ≡ Interrupt active. Where [p] is the port number (0to3).</p> <p>RIS <b>Interrupt Status (RTC):</b> 1≡ Interrupt active.</p> <p>ID[1..0] <b>PLD ID:</b> Begins at "1" and increments.</p> <p>Rev[3..0] <b>PLD Revision:</b> Begins at "1" and increments.</p> <p>PBL <b>Push Button Latch:</b> = 1 whenever the pushbutton was previously pressed (self-cleared at the end of the Read).</p> <p>Busy <b>LIFC Register Busy:</b> This bit goes high (=1) whenever a Line Interface Control Register is written, and goes low (=0) whenever the register is available to be used again. (See the LIFC register above).</p>	15	14	13	12	11	10	9	8	7	6	5	4	3	2	1	0	Busy	PBL	Rev[2]	Rev[1]	Rev[0]	ID[1]	ID[0]	RIS	IS2[3]	IS2[2]	IS2[1]	IS2[0]	IS1[3]	IS1[2]	IS1[1]	IS1[0]	0900 (initially)
15	14	13	12	11	10	9	8	7	6	5	4	3	2	1	0																						
Busy	PBL	Rev[2]	Rev[1]	Rev[0]	ID[1]	ID[0]	RIS	IS2[3]	IS2[2]	IS2[1]	IS2[0]	IS1[3]	IS1[2]	IS1[1]	IS1[0]																						

## System Block Diagrams





## Port Settings, Clock Setup and General Settings

Required [conditions]

Optional [conditions]

(blank) means setting parameter is not required for the mode.

TBD means To be Determined at a later date.

Serial Mode ( <i>smode</i> ) ⇒ BHN_PortSettings ↓	Async	MonoSync	BiSync	Trans-BiSync	HDLC
<i>smode</i>	Required	Required	Required	Required	Required
<i>misc_receiver</i>	TBD	TBD	TBD	TBD	TBD
<i>misc_transmitter</i>	TBD	TBD	TBD	TBD	TBD
<i>r/txclk.ref_freq</i>	Optional [1]	Optional [1]	Optional [1]	Optional [1]	Optional [1]
<i>r/txclk.bps_error</i>	Optional [1]	Optional [1]	Optional [1]	Optional [1]	Optional [1]
<i>r/txclk.bps</i>	Optional [1]	Optional [1]	Optional [1]	Optional [1]	Optional [1]
<i>r/txclk.bps_frac</i>	Optional [1]	Optional [1]	Optional [1]	Optional [1]	Optional [1]
<i>r/txclk.async_div</i>	Required				
<i>r/txclk.dpll_div</i>		Optional [2]	Optional [2]	Optional [2]	Optional [2]
<i>r/txclk.ctr_div</i>	Optional [3]	Optional [3]	Optional [3]	Optional [3]	Optional [3]
<i>r/txclk.enc_dec</i>	Required [1]	Required	Required	Required	Required
<i>r/txclk.clk_tree.A</i>	Required	Required	Required	Required	Required
<i>r/txclk.clk_tree.B</i>		Optional [4]	Optional [4]	Optional [4]	Optional [4]
<i>r/txclk.clk_tree.C</i>	Optional [5]	Optional [5]	Optional [5]	Optional [5]	Optional [5]
<i>r/txclk.clk_tree.D</i>	Required	Required	Required	Required	Required
<i>r/txclk.clk_pin</i>	Required	Required	Required	Required	Required
<i>tx_pre_idle.pre_pat</i>		Optional	Optional	Optional	
<i>tx_pre_idle.pre_len</i>		Optional	Optional	Optional	
<i>tx_pre_idle.tx_idle</i>	Required	Required	Required	Required	Required
<i>line_mode</i>	Required	Required	Required	Required	Required
<i>duplex mode</i>	Required	Required	Required	Required	Required
<i>sync_addr.tx0</i>		Required	Required	Required	
<i>sync_addr.tx1</i>			Required	Required	
<i>sync_addr.tx_len</i>		Required	Required	Required	

Serial Mode ( <i>smode</i> ) ⇒ BHN_PortSettings ↓	Async	MonoSync	BiSync	Trans-BiSync	HDLC
sync_addr.rx0		Required	Required	Required	Required
sync_addr.rx1			Required	Required	Optional
sync_addr.rx_len		Required	Required	Required	
sync_addr.strip_sync		Optional	Optional	Optional	
dbits.t/rx	Required	Required	Required	Required	Required
tx_frac_stop	Required				
parity.t/rx	Required				
crc.tx_type		Required	Required	Required	Required
crc.tx_start		Optional [6]	Optional [6]	Optional [6]	Optional [6]
crc.tx_mode		Optional [6]	Optional [6]	Optional [6]	Optional [6]
crc.rx_type		Optional [6]	Optional [6]	Optional [6]	Optional [6]
crc.tx_start		Optional [6]	Optional [6]	Optional [6]	Optional [6]
tx_trig_gate	Required	Required			
rx_gate	Required	Required			

Required [1]: Must be NRZ or NRZ\_INV

Optional [1]: Needed if a clocking source feeds either of the Baud Rate Generators. If the Receiver or Transmitter are clocked directly from certain Line Interface signals (RxC or TxC setup as inputs) and those Interface signals are setup as outputs, then the indicated parameters are required.

Optional [2]: Required only when the DPLL is part of the clocking tree setup.

Optional [3]: Required only when either Counter (CTR-0 or CTR-1) is directly clocking the Receiver, Transmitter, RxC or TxC signals.

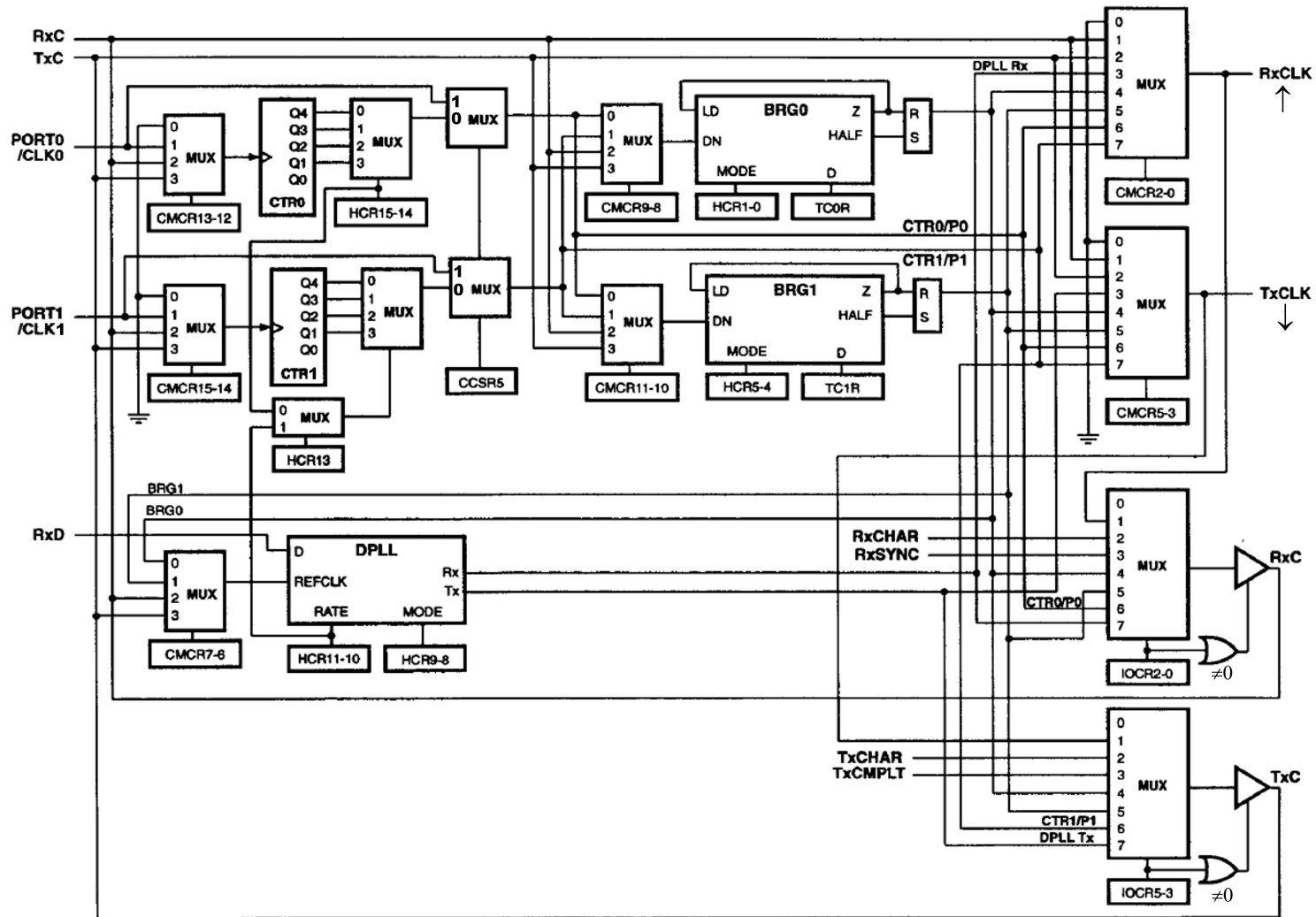
Optional [4]: Only required when the clk\_tree.A setting is CLK\_DPLL (which is generally only used with Synchronous modes).

Optional [5]: Only required when the clk\_tree.A or clk\_tree.C setting selects a Baud Rate generator.

Optional [6]: Only required if CRC is enabled.

## IUSC Clocking Logic:

The following diagram was scanned from the IUSC manual page 4-3 and corrections have been made. Do not use the diagram from the IUSC manual, use the corrected version we have provided below.



## Appendix

### Blue Heat/Net Sync Specifications

#### Operating Environment

4 port model: 0°C to 60°C (32°F to 158°F)

#### Communications

**Baud Rates:**

*Synchronous:* Up to 9.216 Mbps with internal reference clock, up to 10 Mbps with external reference clock.

*Asynchronous:* 230.4 Kbps

Custom baud rates are also available. Please contact our [sales@connecttech.com](mailto:sales@connecttech.com) department for information.

#### ESD Protection

15kV

#### Power

Rev A models: 5V (2.5A) power input using a DC barrel or Phoenix screw terminal connector.

Rev B models: 5V (2.5A) to 26V (450mA) power input using a DC barrel or Phoenix screw terminal connector.

#### Connectors

Serial I/O: DB25 Female

Auxiliary I/O: DB9 Female

DC Power: Standard DC Power connector or Phoenix screw terminal

Ethernet: RJ45

#### Dimensions

*Blue Heat/Net Sync*

- Length: 133 cm/5.24 inches
- Width: 244 cm/9.61 inches
- Height: 43 cm/4.69 inches

Compliant with 1U 19" rack specifications

#### Cable and Power Supply Options

*Blue Heat/Net Sync products are available in a variety of configurations. Please contact the Connect Tech [sales@connecttech.com](mailto:sales@connecttech.com) department for more information on your model number.*

## **Protocol Descriptions**

The Blue Heat/Net Sync supports a variety of protocols. The following is a brief explanation of each and how they are implemented.

### **ARP**

Address Resolution Protocol, a method used to find a unit's Ethernet MAC address from its Internet address.

### **BOOTP**

Bootstrap Protocol, a protocol that allows a unit to boot from the network instead of using information stored on the Blue Heat/Net Sync (typically in Flash memory).

### **DHCP**

Dynamic Host Configuration Protocol, a protocol that provides a means to dynamically allocate IP addresses to computers on a local area network. The system administrator assigns a range of IP addresses to DHCP and each client device on the Local Area Network requests an IP address from the DHCP server. The request and grant process uses a lease concept with a controllable time period. The Blue Heat/Net Sync offers this as a configurable option; it can either be turned on or the user can set a fixed IP on the unit.

### **HTTP**

HyperText Transfer Protocol, a standardized Protocol that Web Browsers use to connect to web pages. It is used to provide web based configuration tools on the Blue Heat/Net.

### **IP**

Internet Protocol, a common addressing scheme for modern networks. Used in conjunction with TCP to form TCP/IP (see below)

### **RARP**

Reverse Address Resolution Protocol, a method to find a unit's Internet address from a MAC or Ethernet address.

### **TCP**

Transmission Control Protocol, a lossless protocol, requiring a handshake to insure that data is not lost during transmission. Used in TCP/IP to form the main data transfer pathway between Blue Heat/Net Sync units and the host computer.

### **Telnet**

A terminal-protocol that can be run over TCP/IP to connect to a remote unit. It is one of the methods used to configure the Blue Heat/Net Sync unit.

### **TFTP**

Trivial File Transfer Protocol, a protocol used to download firmware to the Blue Heat/Net.

### **UDP**

User Datagram Protocol, a protocol used when handshake is not critical. It is used by TFTP (see above) and for auto discovery of the units.

## Pinouts

### DB-25 Female Pinouts

DB25F Pin #	Signal Name V.28 in brackets	Line Mode				
		V.35	EIA-530	RS232 (V.28)	EIA-530A	X.21 (V.11)
14	TX+	V.35 <sup>[4]</sup>	V.11	Hi-Z	V.11	V.11
2	TX- (TX)	V.35 <sup>[4]</sup>	V.11	V.28	V.11	V.11
16	RX+	V.35 <sup>[4]</sup>	V.11 <sup>[1]</sup>	Hi-Z	V.11 <sup>[1]</sup>	V.11 <sup>[1]</sup>
3	RX- (RX)	V.35 <sup>[4]</sup>	V.11 <sup>[1]</sup>	V.28	V.11 <sup>[1]</sup>	V.11 <sup>[1]</sup>
23	DTR+	Hi-Z	V.11	Hi-Z	Hi-Z	V.11
20	DTR- (DTR)	V.28	V.11	V.28	V.10	V.11
19	RTS+	Hi-Z	V.11	Hi-Z	V.11	V.11
4	RTS- (RTS)	V.28	V.11	V.28	V.11	V.11
13	CTS+	Hi-Z	V.11	Hi-Z	V.11	V.11
5	CTS- (CTS)	V.28	V.11	V.28	V.11	V.11
21	DSR+	Hi-Z	V.11	Hi-Z	Hi-Z	V.11
6	DSR- (DSR)	V.28	V.11	V.28	V.10	V.11
10	DCD/RX_SYNC_IN+ <sup>[5]</sup>	Hi-Z	V.11	Hi-Z	V.11	V.11
8	DCD/RX_SYNC_IN- <sup>[5]</sup> (DCD)	V.28	V.11	V.28	V.11	V.11
11	TXC+ <sup>[2]</sup>	V.35 <sup>[4]</sup>	V.11 <sup>[2]</sup>	Hi-Z	V.11 <sup>[2]</sup>	V.11 <sup>[2]</sup>
24	TXC- <sup>[2]</sup> (TXC)	V.35 <sup>[4]</sup>	V.11 <sup>[2]</sup>	V.28	V.11 <sup>[2]</sup>	V.11 <sup>[2]</sup>
9	RXC+ <sup>[2]</sup>	V.35 <sup>[4]</sup>	V.11 <sup>[2]</sup>	Hi-Z	V.11 <sup>[2]</sup>	V.11 <sup>[2]</sup>
17	RXC- <sup>[2]</sup> (RXC)	V.35 <sup>[4]</sup>	V.11 <sup>[2]</sup>	V.28	V.11 <sup>[2]</sup>	V.11 <sup>[2]</sup>
15	(TXC)	NC	NC	V.28	NC	NC
12	RX_SYNC_OUT- <sup>[6]</sup>	V.28	NC	V.28	NC	NC
22	RI (RI)	V.28	V.10	V.28	V.10	Hi-Z
18	TX_TRIGGER	<sup>[7]</sup>	<sup>[7]</sup>	<sup>[7]</sup>	<sup>[7]</sup>	<sup>[7]</sup>
7, 1	SR	SR	SR	SR	SR	SR

<sup>[1]</sup> 120 ohm resistor applied between the (+) and (-) signals.

<sup>[2]</sup> 120 ohm resistor applied between the (+) and (-) signals when the signal is an input.

<sup>[3]</sup> This signal can be programmed to be a input or an output.

<sup>[4]</sup> V.35 Termination Network is applied between (+) and (-) signals.

<sup>[5]</sup> External Sync input used to enable or disable the receiver. This pin is used in external Sync mode. A logical low will enable the receiver.

<sup>[6]</sup> This output indicates that the Receiver has received a RX Sync character. It could also be used as a general purpose I/O signal.

<sup>[7]</sup> See the table titled Auxiliary Connector under TX\_TRIGGER for details.

NC means DO NOT CONNECT.

#### Signal Description:

Mode	Equivalent Standard	Electrical	Typical Voltage
V.10	RS-423	Single ended	+/- 5VDC
V.11	RS-422 / RS485	Differential	1.5VDC to 4.5VDC
V.28	RS-232	Single ended	+/-12VDC
V.35	V.35	Differential	550mVDC

Table 7: DB-25 Female Pinouts

## DB-9 Female Pinouts

DB9F Pin	Signal Name [1]	Functional	Notes
1	RTC_Clear	Clears and holds the seconds count of the Real Time Clock at 00.	[3], [6]
2	RTC_Seconds	Provides the external time base for the Real Time Clock. Internal time base is 1Hz	[3], [5]
3	GND	Signal reference for all signals	
4	EXT_REF_CLK	0-20MHz clock input	[2]
5	GND	Signal reference for all signals	
6	TX_TRIGGER_P1	Transmission trigger for port 1	[3], [4], [5]
7	TX_TRIGGER_P2	Transmission trigger for port 2	[3], [4], [5]
8	TX_TRIGGER_P3	Transmission trigger for port 3	[3], [4], [5]
9	TX_TRIGGER_P4	Transmission trigger for port 4	[3], [4], [5]

[1] All signals are inputs.

[2] Electrical properties for External Reference clock input:

- +/- (1-10)Vpp AC sine wave
- +/- (3.3-10Vpp square wave.
- 10-20MHz Frequency range.
- Capacitive coupled input.
- Must be referenced to GND pin.
- TTL compatible. For example 0-3.3V or 0-5V will work.

[3] Electrical properties:

- +/- (3.3- 10)Vpp pulse.
- Minimum pulse width is 100ns seconds.
- Capacitive coupled input.
- Must be referenced to GND pin.
- TTL compatible. For example 0-3.3V or 0-5V will work.

[4] Used for Asynchronous transmissions. When the mode is enabled, the Blue Heat/Net Sync will transmit exactly one byte of data when the TX\_TRIGGER input changes state. These same signals are available on the individual DB25 port connectors.

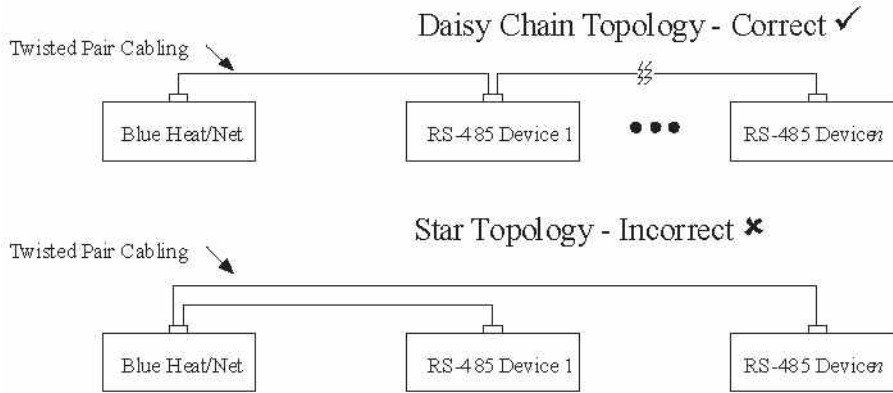
[5] The input is edge sensitive and can be configured for negative or positive edge sensitivity.

[6] The input is level sensitive and can be configured for 1 or 0 level sensitivity.

**Table 8: DB-9 Female Pinouts**

## Multi-drop Communications Using V.11 / RS422/RS485 Line Modes

When wiring multi-drop RS-485 networks, it is necessary to wire the devices in a “Daisy Chain”, they must not be wired with a “Star” topology, see diagram.



### Rack Mount Option:

Blue Heat/Net Sync can be rack mounted using the option rack mount kit part number MSG029.

## Default Settings

### Network Settings

Blue Heat/Net Sync IP address	192.168.42.1
Server IP address	0.0.0.0 (used for firmware downloads)
Gateway IP address	0.0.0.0
Subnet Mask	255.255.255.0
Broadcast IP address	255.255.255.255 (used by the bootp process)
Domain Name Server IP address:	0.0.0.0 (used for firmware downloads)
Domain Name	blueheat.net
Host Name	BHNsssssss (where sssssss is the BHN serial number)
TCP Port	49152 (0xC000)
DNS IP	0.0.0.0

### Boot Settings

Default enabled:  
    Boot from Flash

Default disabled:  
    use BOOTP  
    use TFTP

Delay: 30 (seconds)

### SCM Operation Settings

Password: password

Password Prompting: enabled

Loader Filename: BHNloader\_vvv.gz  
(where vvv is the version number of the Loader, current at the time the unit was manufactured).

Line Setting: See [Getting Access to the SCM](#) section.

## Common Configuration Setups

### Static IP Setup

In some networking environments it is best to have the IP address set to a fixed value. The advantage is that since it is fixed, connecting to it can be a lot simpler.

Static IP is often the best choice if you are trying to connect via WAN or through a Firewall. It can be difficult to resolve the Blue Heat/Net Sync's IP address if you use DHCP in this instance.

The default configuration is a static IP of 192.168.42.1. In most cases this will not be the address you want to use in your network. You can change it using two different methods:

Serial Configuration Manager (SCM)

A direct serial connection to one of the serial ports on the Blue Heat/Net Sync.

Or

Web Configuration Manager (WCM)

Using a web browser like Internet Explorer to connect to the unit.

Refer to the manual sections for specific details on using the SCM and WCM.

Example:

You want to configure a static IP on a Blue Heat/Net Sync of 198.182.196.15. The network's server is at 198.182.196.1 and the gateway is 198.182.196.2. The subnet mask is 255.255.255.0.

### Using SCM

Log onto the Blue Heat/Net Sync. There is no login necessary if using SCM. The default password for the SCM is **password**.

Enter **net net=198.182.196.0**. This will set 198.182.196.0 to the server, gateway and the unit's IP in one step.

Enter **net my\_ip=15**. This will set the unit's IP to 198.182.196.15.

Enter **net server\_ip=1**. This will set the server IP to 198.182.196.1.

Enter **net gateway\_ip=2**. This will set the gateway IP to 198.182.196.2.

Enter **net subnetmask=255.255.255.0**. This will set the subnet mask.

Enter **net dns\_ip=3**. This will set the DNS IP to 198.182.196.3

Enter **net dhcp=no**. This will turn off DHCP on the unit.

Enter **save**. This will save the configuration set above to flash memory.

Enter **exit**. The unit will reboot using the new settings.

### Using WCM

Connect to the Blue Heat/Net Sync using a web browser by entering the current IP of the unit in the address.

Log on by supplying the username and password. The default login is **wcm** and the default password is **password**.

Select the **Blue Heat/Net Sync Settings** page and fill in the server IP, Blue Heat/Net Sync IP, Gateway IP, DNS IP and subnet mask as defined above.

Ensure the Use DHCP option is set to **no**

Click on the **Save to Flash** button to store the changes.

## DHCP Setup

In many modern networks IP numbers are not static but are automatically assigned by a DHCP server and can change over time or on each power up.

DHCP must be enabled on the Blue Heat/Net Sync because it is shipped to use a default static IP (192.168.42.1)

### Using SCM

Log onto the Blue Heat/Net Sync. The SCM does not require a login. The default password for the SCM is **password**.

Enter **net dhcp=yes**. This will turn on DHCP on the unit.

Enter **net dns\_ip=3**. This will set the DNS IP to 198.182.196.3

Enter **save**. This will save the configuration we just set to flash memory.

Enter **exit**. The unit will reboot using the new settings.

## How the Blue Heat/Net Sync Boots Up

Each time the Blue Heat/Net Sync is powered-up or rebooted with an appropriate command, a certain sequence of software execution occurs.

The **Booter** runs from flash memory first. Its job is to perform the following:

Setup the embedded processor

Validate at least one of the redundant **Loaders** (via a CRC check).

Load a validated **Loader** into RAM memory.

Run the **Loader**.

If the **Booter** discovers that both **Loader** programs are defective (erased or faulty CRC calculation), an error code is displayed on the LEDs of the Blue Heat/Net Sync.

The **Loader** runs from RAM memory. Its job is to perform the following:

- Update any required CDS items.
- Determine if the SCM application will be entered. This is accomplished by scanning the designated serial ports, for a period of time, to determine if a correct password is entered. If the password is found the SCM application will be entered. (see the [SCM Command Reference](#) command for details of these settings).
- Locate, load and run an Operating System (uClinix). (As shown in the following boot-up flow chart).
- Run the main Operating System (uClinix).
- Operating System launches port personality default **ctid**

## Bootup Sequence

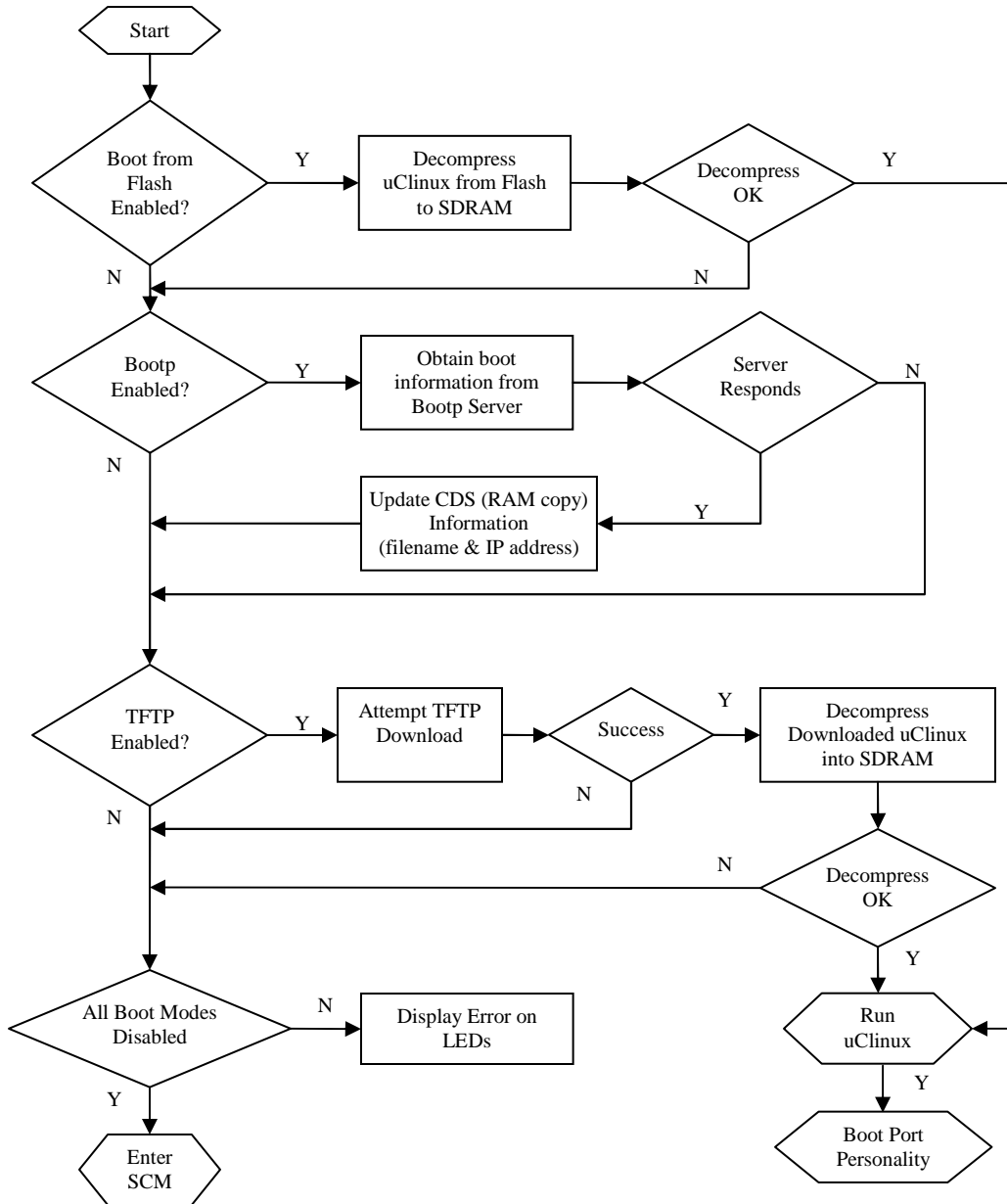


Figure 46: Bootup Sequence

### Flowchart of Special Operations Mode using the reset button

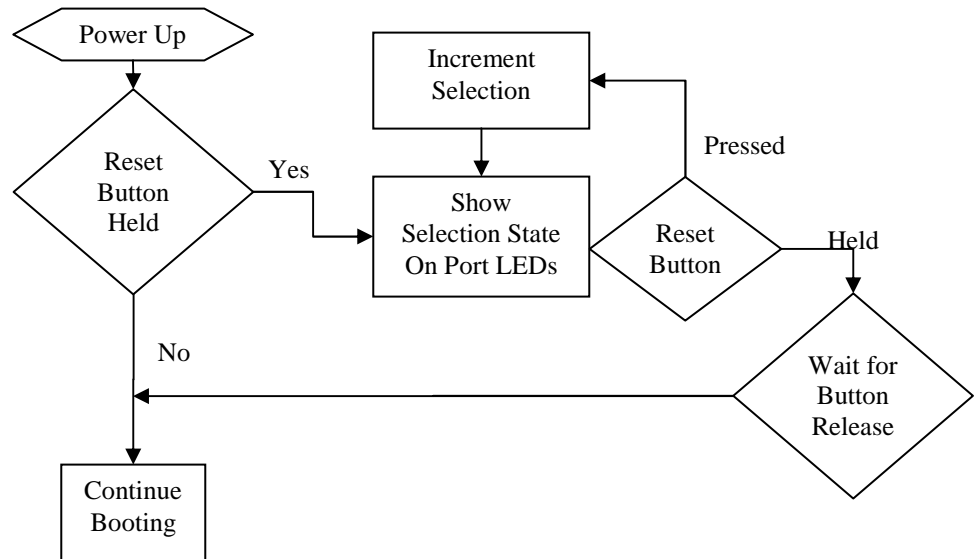


Figure 47: Bootup Sequence via Reset Button

### Asynchronous Communications Tutorial

The Blue Heat/Net Sync features four synchronous/asynchronous serial communication ports. Asynchronous communication is a simple, cost effective means of terminal serial communication. For this reason, it is widely used for communications on personal computers, bar codes readers, printers, terminals and much more. The following documentation represents a basic tutorial for asynchronous communications. For a tutorial on synchronous communications, please refer to the **Z16C32 IUSC User's Manual (DOC ID DC8292)** on the [Zilog website](#).

In asynchronous serial communication, the electrical interface is held in the idle position between characters, also referred to as "mark". A change in signal level (known as space level) indicates the start of transmission of a character. The receiver recognizes this change as a "start bit". Once the start bit has been sent, the transmitter sends the actual data bits. In typical asynchronous communications there may be 5, 6, 7, or 8 data bits, depending on the application. Both the receiver and the transmitter must be set to the same number of data bits, baud rate and stop bits. Stop bits can be 1, 1.5, or 2 bit periods in length. When the transmitter has sent all the data bits, it sends a stop bit. This stop bit signals to the receiver that the data has finished transmission. The stop bit is the same state as the idle or mark state.

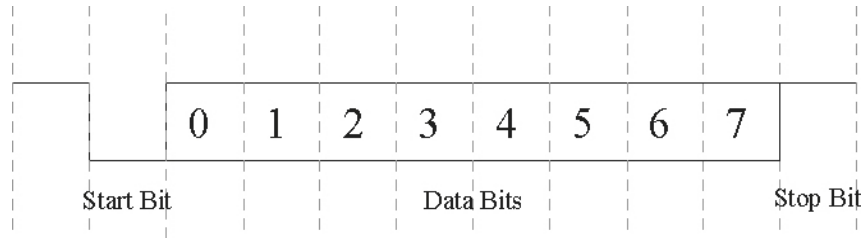


Figure 48: Typical Asynchronous Date Frame

## Serial Line Interface Tutorial

### RS-232 Line Interface:

RS-232 is the simplest, least expensive line interface standard, the Sipex transceivers used on the Blue Heat/Net Sync refer to RS232 as V.28 mode. It is also referred to as EIA232 and TIA/EIA-232. The RS-232 specification signals levels of +3V to +15V for a logic 0 or Space, and -3V to -15V for a logic 1 or Mark. The Blue Heat/Net Sync has RS-232 signal levels with a typical range of +/- 8 Volts. The maximum cable length you can use with RS-232 is dependant on a number of factors including:

**Baud rate:** The higher the baud rate, the shorter the cable length must be.

**Cable quality:** Quality largely refers to the capacitance of the cable. A higher capacitance (usually specified as pF or pico Farads per foot) dictates a lower baud rate, and a shorter maximum length. Low capacitance computer cables for RS-232 applications are available from all wire and cable suppliers.

You can usually operate with cable lengths of up to 100 feet (30 m) at baud rates up to 115.2 Kbps using low capacitance cable. For higher baud rates such as 230.4 Kbps and up, we recommend keeping the cable lengths to within 25 feet (7.6 m).

The TIA/EIA232 specification specifies two connectors: the DB-25 and the DB-9. Each of these connectors has a standardized pinout. Refer to the [Pinouts](#) section of the manual for the DB-25 RS-232 (V28) pinout.

### Differential Line Interfaces:

The Blue Heat/Net Sync features Sipex SP508 multi-protocol transceivers. These transceivers features the following differential line standards.

V.11: A differential line interface with signal levels compatible with RS-485 and RS-422.

V.10: A single ended line interface that can be wired such that it will have some of the noise cancelling features of RS485 (V.11). This interface is also called RS-423.

V.35: A differential line interface that operates in a current loop. The electrical levels are about +/- 550mV.

### RS485/RS422/V.11 Details

V.11, RS-485, or TIA/EIA485, is a differential line interface standard capable of high baud rates over long cables. The Sipex transceivers used on the Blue Heat/Net Sync refer to RS-485 as V.11

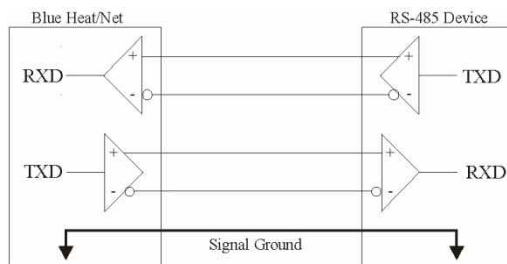
mode RS-485 is fully compatible with RS-422; which is considered a subset of RS-485. The use of differential transmitters and receivers ensures RS-485 communications are reliable and robust. This means two wires are used to transmit or receive a signal. One wire carries the true or non-inverted signal; the other wire carries the inverted signal. The non-inverted signal is labelled with a (+) and the inverted is labelled with a (-). The differential communication refers to the (+) as “TXB” and the (-) as “TXA”.

Any noise injected into the wires is cancelled at the receiver, leaving only the original, undistorted data signal. Twisted pair cables are always used in RS-485, this ensures that the communications are robust and as error free as possible. RS-485 signal levels are between 0 and 5 Volts, the differential voltage can be as little as 200mV.

Differential can operate in three different modes: a 4-wire full duplex interface, 4-wire multi-drop full duplex interface and a 2-wire half duplex interface. A full duplex (bi-directional) differential communication interface requires at least four wires, two for transmit and two for receive. A half duplex interface only requires two wires, this provides a cost effective cabling solution.

Multi-drop is a great feature of RS-485. Multiple RS-485 devices can be bussed together in a daisy chain type fashion to create a network. Up to 32 devices may be connected together on the same network. In multi-drop networks, one of the devices (usually the computer) is designated as the master, and all the other devices are designated as slaves. All communication is initiated by the master. The master and slave designations are established by your communications application.

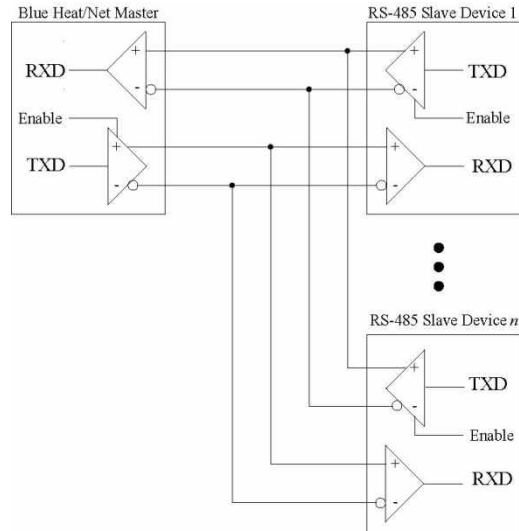
#### **Basic 4-Wire, Full Duplex Communications:**



In a 4-wire RS-485 network, two devices are connected together, for example your Blue Heat/Net Sync RS-485 port and an RS-485 device.

**Multi-drop 4-Wire, Full Duplex Communications:**

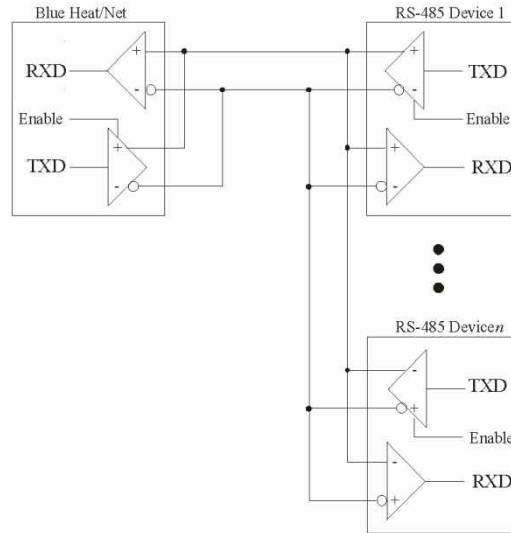
In a multi-drop 4-wire differential network, two to 32 devices are connected together. Note that each RS-485 receiver counts as a device or “load”. In this multi-drop mode of communication, a master slave protocol must be enforced, that is, all communication is initiated by the master, in this case a Blue Heat/Net Sync. The communication is “full duplex”, meaning that receive and transmit traffic occur on different pairs of wires. The Blue Heat/Net Sync can receive and transmit data from/to a device at the same time.



**Basic - Wire, Half Duplex Multi-drop Connection:**

In a 2-wire differential network, two to 32 devices are connected together. Note that each receiver counts as a device or “load”. In this multi-drop mode of communication a master slave protocol must be enforced, that is, all communication is initiated by the master, in this case a Blue Heat/Net Sync. The communication is “half duplex”, meaning that receive and transmit traffic occur on the same wire. The Blue Heat/Net Sync and devices can not receive data and transmit data at the same time.

Note that the Receiver +/- and the Transmitter +/- signals are connected together. This is performed at the DB-9 connectors. All communication between devices occurs over a single pair of wires; this can lower the cost of wiring your network.



### ***Bus Contention on Differential Multi-drop Networks:***

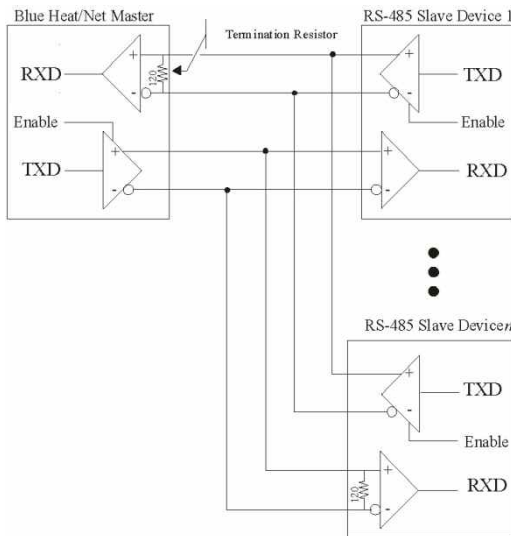
Bus contention occurs when two or more devices enabled on a bus attempt to run the bus to opposite logic values. From the diagram above, we can see that there are multiple differential transmitters (TXD) on the bus. To avoid the bus contention problem, the differential transmitter features a tri-state, or high impedance mode controlled by an input pin (enable). Software and hardware in the Blue Heat/Net Sync and the differential devices will always place its transmitter into the high impedance mode when not transmitting. This feature is managed by the Blue Heat/Net Sync and is fully transparent to your application.

For example, in a multi-drop network, the differential transmitter is enabled prior to the master initiating transmission. When transmission is complete, the transmitter is placed in high impedance mode. Each slave will receive that transmission from the master. (A protocol must be in place to address, or select, the desired slave device, but that discussion is beyond the intentions of this tutorial, and is entirely application dependent). When the slave device has received the data, it will respond by enabling its transmitter and transmitting data onto the bus, then placing its transmitter into high impedance mode, just as the master did.

## Termination Resistors in Differential Networks

### Termination Resistors in Differential Networks:

Differential networks often benefit from the installation of termination resistors. Termination is rarely required for lower baud rates, for example 9600 baud or less. However, differential networks are *transmission lines*, and can suffer from the electrical effects of ringing, or undershoot and overshoot, all of which can cause data errors, especially at higher baud rates, like 115.2 Kbps. Termination resistors should always be installed at the extreme ends of the network, as close to the differential transceiver circuits as possible, as outlined in the diagram below.



**NOTE:** The Blue Heat/Net Sync features software selectable termination.