



Connect Tech Inc.
Industrial Strength Communications

Blue Heat/PCI

PCI Serial Communications

User Manual

Connect Tech Inc.
42 Arrow Road
Guelph, Ontario
N1K 1S6
Tel: 519-836-1291
Toll: 800-426-8979 (North America only)
Fax: 519-836-4878
sales@connecttech.com
support@connecttech.com
www.connecttech.com

Limited Lifetime Warranty

Connect Tech Inc. provides a Lifetime Warranty for all Connect Tech Inc. products. Should this product, in Connect Tech Inc.'s opinion, fail to be in good working order during the warranty period, Connect Tech Inc. will, at its option, repair or replace this product at no charge, provided that the product has not been subjected to abuse, misuse, accident, disaster or non Connect Tech Inc. authorized modification or repair.

You may obtain warranty service by delivering this product to an authorized Connect Tech Inc. business partner or to Connect Tech Inc. along with proof of purchase. Product returned to Connect Tech Inc. must be pre-authorized by Connect Tech Inc. with an RMA (Return Material Authorization) number marked on the outside of the package and sent prepaid, insured and packaged for safe shipment. Connect Tech Inc. will return this product by prepaid ground shipment service.

The Connect Tech Inc. Lifetime Warranty is defined as the serviceable life of the product. This is defined as the period during which all components are available. Should the product prove to be irreparable, Connect Tech Inc. reserves the right to substitute an equivalent product if available or to retract Life Time Warranty if no replacement is available.

The above warranty is the only warranty authorized by Connect Tech Inc. Under no circumstances will Connect Tech Inc. be liable in any way for any damages, including any lost profits, lost savings or other incidental or consequential damages arising out of the use of, or inability to use, such product.

Copyright Notice

The information contained in this document is subject to change without notice. Connect Tech Inc. shall not be liable for errors contained herein or for incidental consequential damages in connection with the furnishing, performance, or use of this material. This document contains proprietary information that is protected by copyright. All rights are reserved. No part of this document may be photocopied, reproduced, or translated to another language without the prior written consent of Connect Tech, Inc.

Copyright © 1997 - 2006 by Connect Tech, Inc.

Trademark Acknowledgment

Connect Tech, Inc. acknowledges all trademarks, registered trademarks and/or copyrights referred to in this document as the property of their respective owners.

Not listing all possible trademarks or copyright acknowledgments does not constitute a lack of acknowledgment to the rightful owners of the trademarks and copyrights mentioned in this document.

Table of Contents

Limited Lifetime Warranty	2
Copyright Notice	2
Trademark Acknowledgment.....	2
Table of Contents.....	3
Customer Support Overview.....	5
Contact Information.....	5
Certification	6
Introduction	7
Features	7
Hardware Installation.....	14
Installing the Blue Heat/PCI Adapter in your System	14
Configuration	14
Baud Rate Selection	15
RS-422/485 Line Interface	15
Full Duplex Mode.....	15
Half Duplex Mode.....	15
Multi-drop Slave Mode.....	15
20mA Current Loop Interface.....	15
Software Installation.....	16
Introduction	16
Appendix A: Specifications	17
Operating Environment	17
Power Requirements.....	17
PCI Bus Interface	18
Communications.....	18
Control Signals	18
Surge Suppression	19
Optical Isolation.....	19
Dimensions.....	19
Connectors/Interface.....	20
Appendix B: Connectors/Pinouts.....	21
Connector Pinouts	21
Connector Box Pinouts.....	28
Appendix C: RS-422/485 Line Interface	31
Blue Heat/PCI RS-422/485	31
Full Duplex Mode.....	31
Half Duplex Mode.....	31
Multi-drop Slave Mode.....	31
Line Bias/Termination	31
Universal Blue Heat/PCI RS-422/485	31
Tri-state Control.....	31
Blue Heat/PCI RS-422/485 (6+2 model).....	32
Tri-state Control.....	32
Line Bias/Termination	32
Blue Heat/PCI Opto and Opto RS-422/485	35
Electrical Interface Selection	35
Full Duplex Mode.....	35
Half Duplex Mode	36
Multi-drop Slave Mode.....	36
Tri-state Control.....	36
Line/Bias Termination	37
RS-422/485 Cable Wiring	38
Appendix D: 20mA Current Loop Line Interface	40
Blue Heat/PCI 20mA CL	40
Current Source/Voltage Selection.....	41
Current Loop Cable Wiring	42
Appendix E: Blue Heat/PCI PTM model.....	43
Blue Heat/PCI PTM Adapter.....	43
Features	43
Specifications for the Blue Heat/PCI PTM.....	44

Power Requirements	44
Communications	44
Control Signals	44
Dimensions	44
Connectors/Interface	44
Part Numbers	44
Certification.....	45
Connectors/Pinouts.....	45

List of Figures

Figure 1: Blue Heat/PCI Adapters.....	9
Figure 2: Blue Heat/PCI RS-422/485 adapters.....	10
Figure 3: Universal Blue Heat/PCI RS-422/485 adapters	11
Figure 4: Blue Heat/PCI RS-422/485 adapter (6+2 model)	11
Figure 5: Blue Heat/PCI RJ-11 adapter	12
Figure 6: Blue Heat/PCI Opto adapters	12
Figure 7: Blue Heat/PCI CL adapter.....	13
Figure 8: Blue Heat/PCI, 20-port configuration.....	13
Figure 9: Blue Heat/PCI 2 RS-232 + 6 RS-422/485	13
Figure 10: Blue Heat/PCI, RS-422/485, 20mA CL and Universal Blue Heat/PCI RS-422/485 I/O Box	29
Figure 11: RJ-45 Connector Plug.....	30
Figure 12: Partial schematic: Blue Heat/PCI RS-422/485; Universal Blue Heat/PCI RS-422-485.....	33
Figure 13: Partial schematic: Blue Heat/PCI Opto.....	37
Figure 14: RS-422/485 wiring diagram (4 wire).....	38
Figure 15: RS-422/485 wiring diagram (2 wire).....	39
Figure 16: Partial schematic: Blue Heat/PCI 20mA CL.....	40
Figure 17: Current Loop wiring diagram (4 wire).....	42
Figure 18: Blue Heat/PCI PTM adapter.....	44
Figure 19: Blue Heat/PCI PTM Connection Modes Diagram.....	46

List of Tables

Table 1: DB-9 pinouts for Blue Heat/PCI RS-232, 422/485 models, Universal Blue Heat/PCI RS-422/485	22
Table 2: DB-9 pinouts for the Blue Heat/PCI Opto	22
Table 3: RJ-45 pinouts for the Blue Heat/PCI Opto	23
Table 4: Blue Heat/PCI RJ-11 port header (P7/P8) pinouts.....	23
Table 5: Blue Heat/PCI RJ-11 pinouts.....	24
Table 6: Blue Heat/PCI 20mA CL pinouts	24
Table 7: DB-37 pinouts for Blue Heat/PCI RS-232 and RS-422/485 models.....	25
Table 8: DB-78 pinouts for Blue Heat/PCI RS-232, RS-422/485, Universal Blue Heat/PCI RS-422/485... ..	26
Table 9: DB-9 pinouts for Blue Heat/PCI RS-232, RS-422/485, 20mA CL and Universal Blue Heat/PCI RS-422/485 I/O Box	29
Table 10: RJ-45 pinouts, RJ-45 connector plug.....	30
Table 11: DB-9 pinouts – Blue Heat/PCI PTM.....	45

Customer Support Overview

If you experience difficulties after reading the manual and/or using the product, contact the Connect Tech reseller from which you purchased the product. In most cases the reseller can help you with product installation and difficulties.

In the event that the reseller is unable to resolve your problem, our highly qualified support staff can assist you. Our support section is available 24 hours a day, 7 days a week on our website at: www.connecttech.com/sub/support/support.asp. See the contact information section below for more information on how to contact us directly. Our technical support is always free.

Contact Information

We offer three ways for you to contact us:

Mail/Courier

You may contact us by letter at:
Connect Tech Inc.
Technical Support
42 Arrow Road
Guelph, Ontario
Canada N1K 1S6

Email/Internet

You may contact us through the Internet. Our email and URL addresses on the Internet are:

sales@connecttech.com
support@connecttech.com
www.connecttech.com

Note:

Please go to the [Download Zone](#) or the [Knowledge Database](#) in the [Support Center](#) on the Connect Tech website for product manuals, installation guides, device driver software and technical tips.
Submit your technical support questions to our customer support engineers via the [Support Center](#) on the Connect Tech website.

Telephone/Facsimile

Technical Support representatives are ready to answer your call Monday through Friday, from 8:30 a.m. to 5:00 p.m. Eastern Standard Time. Our numbers for calls are:

Telephone: 800-426-8979 (North America only)

Telephone: 519-836-1291 (Live assistance available 8:30 a.m. to 5:00 p.m. EST, Monday to Friday)

Facsimile: 519-836-4878 (on-line 24 hours)

Certification

Blue Heat/PCI
Blue Heat/PCI RS-422/485
Blue Heat/PCI RJ-11
Blue Heat/PCI Opto; Opto RS-422/485
Blue Heat/PCI CL
Universal Blue Heat/PCI RS-422/485

Connect Tech Inc. declares that the product(s) covered by the contents of this manual have been tested and found compliant with the below listed standards as required by the Electromagnetic Compatibility (EMC) Directive for General Immunity Compliance, EN 50 0082.1:1997

EN 55022 Conducted and Radiated emissions
CISPR 22 Class A

EN 55024 Immunity to Disturbances

EN 61000-4-2		EN 61000-4-4
EN 61000-4-3		EN 61000-4-6

The above satisfy the requirements of:

USA: FCC – CFR47, Part 15, part 2
Canada: ICES-003
Europe: EMC Directive
Japan: VCCI
Australia/New Zealand: AS/NZS



The above agency conformances were met by independent laboratory testing of Connect Tech Inc. product(s) with shielded cables, with metal hoods, attached to either the terminating connectors or cable assemblies supplied with the product(s). Failure to follow good EMC/EMI compliant cabling practices may produce more emissions or less immunity than were obtained in laboratory measurements.

Operation of this equipment in a residential area may cause unacceptable interference to radio and TV reception, requiring the user to take whatever steps necessary to correct the interference.

Introduction

The Blue Heat/PCI family of adapters includes the Blue Heat/PCI RS-232, RS-422/485, RJ-11, Opto, 20mA CL and Universal Blue Heat/PCI RS-422/485.

Your Blue Heat/PCI product consists of the following components:

- One Blue Heat/PCI adapter
- One cable harness or external connector box (four and eight port models only)
- One CD containing device drivers and documentation

Blue Heat/PCI RS-422/485, RJ-11, Opto, Opto RS-422/485, 20mA CL and Universal Blue Heat/PCI RS-422/485 adapters provide high speed interfaces between a host computer's PCI bus and multiple external serial devices. Up to eight serial devices can connect through one expansion slot via the Blue Heat/PCI.

Features

- 2, 4, or 8 asynchronous serial ports
- Multiple interface options:
 - RS-232 (Blue Heat/PCI and RJ-11 adapters)
 - RS-232 and/or RS-422/485 (Blue Heat/PCI RS-422/485, Opto, Opto RS-422/485 and Universal Blue Heat/PCI RS-422/485 adapters)
 - 20mA Current Loop interface (Blue Heat/PCI CL adapters)
- The Blue Heat/PCI RS-422/485, Opto, Opto RS-422/485, Universal Blue Heat/PCI RS-422/485 offer full RS-422/485 support in hardware. The modes are as follows:
 - Full Duplex Mode
 - Half Duplex Mode
 - Multi-drop Slave Mode
- Different models of Blue Heat/PCI, RS-422/485, RJ-11, 20mA CL, Opto, Opto RS-422/485 and Universal Blue Heat/PCI RS-422/485 adapters may reside in a host computer offering up to 32 ports per system
- 16C654 quad UARTs control two, four or eight ports (Blue Heat/PCI, RJ-11, 20mA CL models)
- 16C864 quad UARTs control two, four or eight ports (Blue Heat/PCI RS-422/485, Universal Blue Heat/PCI RS-422/485 models)
- 16C2850 dual UARTs control two, or four ports (Blue Heat/PCI Opto, /PCI Opto RS-422/485)
- Each port on a Blue Heat/PCI and RJ-11 models offers independent baud rate selection from 21 bps to 1382.4 Kbps, with 5, 6, 7 or 8 data bits and 1, 1.5, 2 stop bits, odd, even, mark and space parity
- Each port on a Blue Heat/PCI RS-422/485, Opto, Opto RS-422/485 and Universal Blue Heat/PCI RS-422/485 adapter offers independent baud rate selection from 50 bps to 921.6 Kbps, with 5, 6, 7 or 8 data bits and 1, 1.5, 2 stop bits, odd, even, mark and space parity
- Each port on a Blue Heat/PCI 20mA CL adapter offers independent baud rate selection from 21 bps to 57.6 Kbps, with 5, 6, 7 or 8 data bits and 1, 1.5, 2 stop bits, odd, even, mark and space parity
- Blue Heat/PCI, Blue Heat/PCI RS-422/485 and Universal Blue Heat/PCI RS-422/485 adapters come with optional Transient Voltage Protection (surge suppression – IEC 1000-4 compatible) on every signal line of every port
- Each port is independently optically isolated to 1K or 3.0kV AC peak to peak (Blue Heat/PCI Opto models)
- The RS-232 line drivers on the first three (3) ports offer double the drive capability of standard RS-232 line drivers (Blue Heat/PCI and RJ-11 models)

- Six RJ-11 connectors provide +12 VDC or +5 VDC output (factory installed) on pin 6 with a current limit of 300 mA total for +12 VDC and 1A total for +5 VDC. (Blue Heat/PCI RJ-11 model)
- System requirements are one 32-bit 5V PCI bus compatible slot (Blue Heat/PCI, RS-422/485, RJ-11, Opto, Opto RS-422/485, 20mA CL, Universal Blue Heat/PCI RS-422/485 adapters) or a 3.3V PCI slot (Universal Blue Heat/PCI RS-422/485 adapters only)
- You can use up to thirty two (32) Blue Heat/PCI, RS-422/485, RJ-11, Opto, Opto RS-422/485, 20mA CL or Universal Blue Heat/PCI RS-422/485 ports per system for larger I/O requirements

Figures 1 through 7 show the locations of various hardware components found on the Blue Heat/PCI, RS-422/485, Opto, Opto RS-422/485, RJ-11, 20mA CL and Universal Blue Heat/PCI RS-422/485 models.

Figure 1: Blue Heat/PCI Adapters

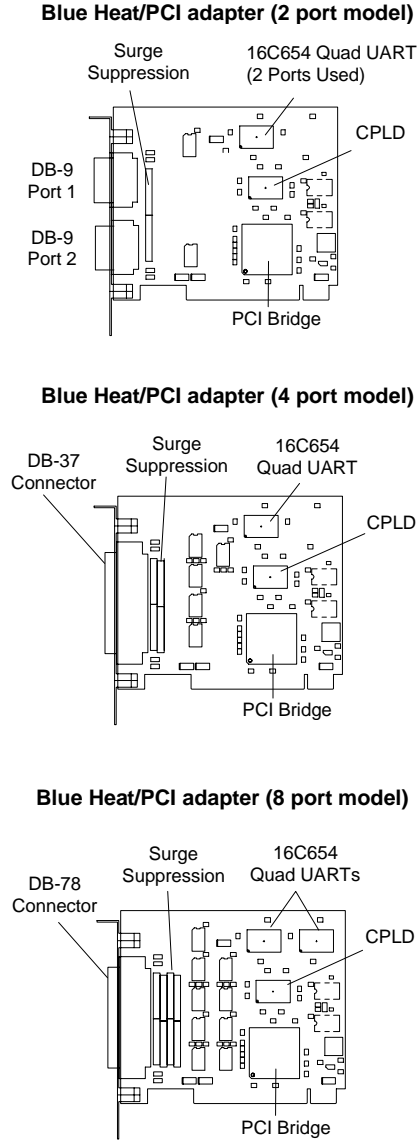
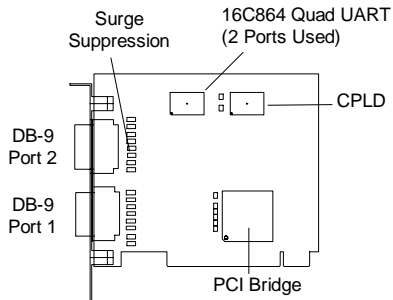
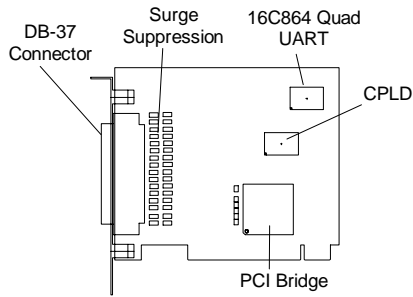

Figure 2: Blue Heat/PCI RS-422/485 adapters

**Blue Heat/PCI RS-422/485 adapter
(2 port model)**



**Blue Heat/PCI RS-422/485 adapter
(4 port & 2+2 models)**



**Blue Heat-8/PCI RS-422/485 adapter
(8 port & 4+4 models)**

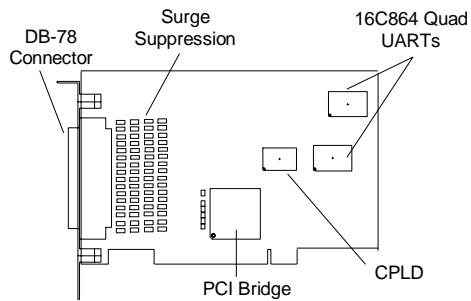

Figure 3: Universal Blue Heat/PCI RS-422/485 adapters

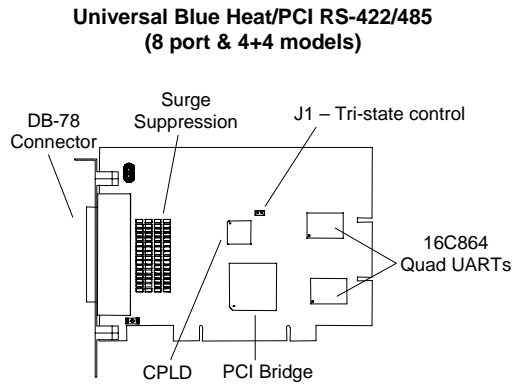

Figure 4: Blue Heat/PCI RS-422/485 adapter (6+2 model)

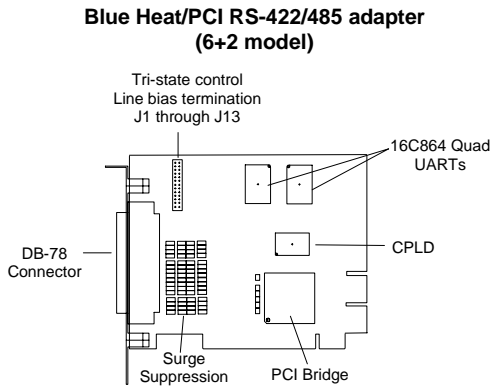

Figure 5: Blue Heat/PCI RJ-11 adapter

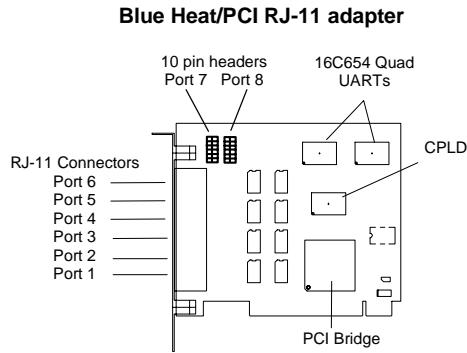
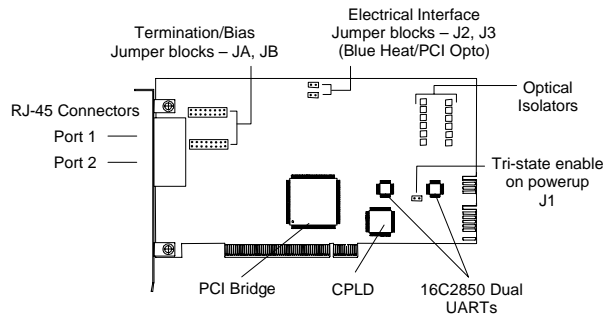

Figure 6: Blue Heat/PCI Opto adapters

**Blue Heat/PCI Opto adapter (2 port model)
Blue Heat/PCI Opto RS-422/485 adapter (2 port model)**



**Blue Heat/PCI Opto adapter (4 port model)
Blue Heat/PCI Opto RS-422/485 adapter (4 port model)**

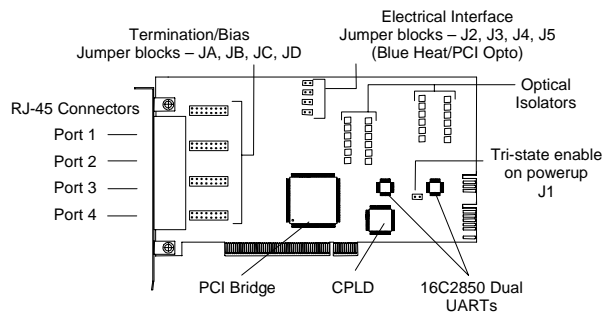
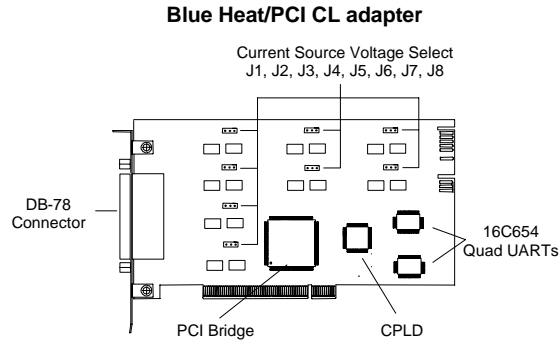

Figure 7: Blue Heat/PCI CL adapter



You can combine different Blue Heat/PCI and Universal Blue Heat/PCI RS-422/485 adapters in a single computer to accommodate both small and large multi-channel applications. [Figure 8](#) below represents a sample configuration for a system requiring 20 ports.

Figure 8: Blue Heat/PCI, 20-port configuration

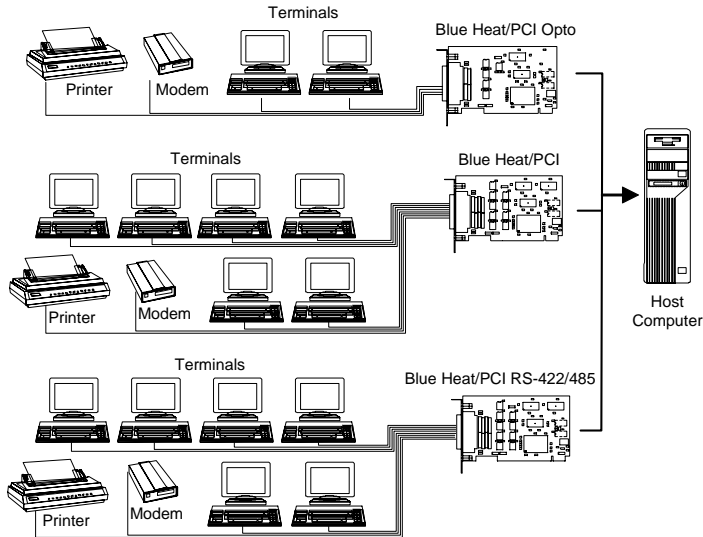
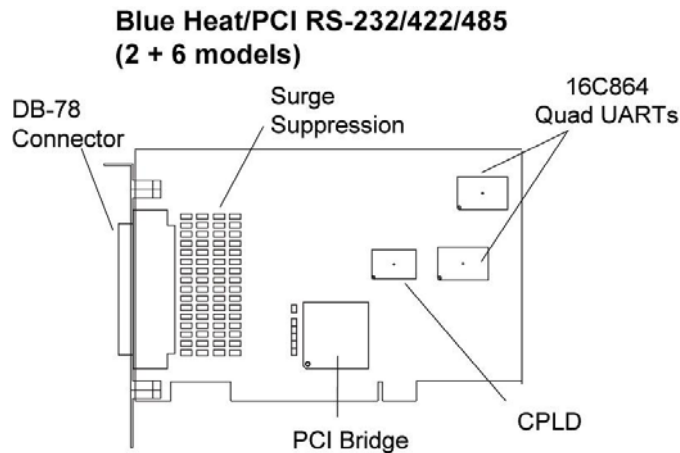

Figure 9: Blue Heat/PCI 2 RS-232 + 6 RS-422/485



Hardware Installation

Hardware installation involves configuration of the following Blue Heat/PCI products:

The Blue Heat/PCI; RS-422/485; Opto; Opto RS-422/485; 20mA CL; RJ-11 and Universal Blue Heat/PCI RS-422/485 adapters

Note: Please see the [Software Installation](#) section for installation of your Blue Heat/PCI or Universal Blue Heat/PCI board under certain operating systems.

Installing the Blue Heat/PCI Adapter in your System

To install your Blue Heat/PCI adapter in your computer follow these steps:

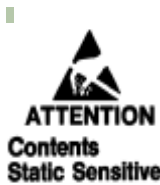

Your Blue Heat/PCI adapter is very sensitive to static electricity. Make sure you wear an anti-static wristband before you remove the card from the anti-static shipping bag. When you remove the board from the anti-static bag, handle it only by the edges and place it on the anti-static bag or an anti-static mat.

1. Turn the power off to your computer.
2. Open your computer to expose the expansion slots (consult the system documentation for information on this procedure.)
3. Choose an available 32-bit 5V PCI expansion slot (Blue Heat/PCI; RS-422/485; RJ-11; Opto; Opto RS-422/485; 20mA CL; Universal Blue Heat/PCI RS-422/485 models) or 3.3V PCI expansion slot (Universal Blue Heat/PCI RS-422/485 models only).

Note: 3.3V and 5V PCI expansion slots are keyed differently to prevent incorrect installation of PCI adapters.

4. Remove the screw and the expansion slot cover from the slot you select and save both.
5. Place the Blue Heat/PCI adapter in the expansion slot and push down gently until the card seats fully in the slot.

Note: Do not force the card into the expansion slot. If you meet a great deal of resistance remove the board and try again.

6. Align the mounting bracket and secure the board with the screw that you saved.
7. Close your computer.

Configuration

Peripheral Component Interconnect (PCI) bus architecture offers a feature called Plug and Play (sometimes referred to as PnP). This feature automatically identifies and configures installed devices each time the system boots.

In most PCI compliant computers, the system BIOS will automatically detect and configure the Blue Heat/PCI adapter. However in some cases a system BIOS cannot resolve all of the requests for resources in the system. This is especially true if you manually assign resources to ISA bus adapters that the PCI devices need. This often occurs with the assignment of system interrupts, since this is usually the scarcest resource.

If this occurs, the driver will signal that a given resource has not been assigned, which requires the user to assign system resources manually. Remove the assignments for ISA devices with the BIOS setup and then reboot the computer. After reboot, determine with the BIOS setup utility what resources have been assigned to the PCI devices and then do manual assignments of free resources to ISA devices. Reboot your system. If the BIOS cannot find a suitable configuration please contact Connect Tech Technical Support.

Baud Rate Selection

Blue Heat/PCI adapters offer ideal solutions for applications requiring serial communications up to 57.6 Kbps (Blue Heat/PCI CL models), 921.6 Kbps (Blue Heat/PCI RS-422/485; Opto; Opto RS-422/485; Universal Blue Heat/PCI RS-422/485 models) or 1382.4 Kbps (Blue Heat/PCI; RJ-11 models). Their baud rates are software selectable, so therefore please refer to the [Software Installation](#) section for configuring the baud rates under certain operating systems.

RS-422/485 Line Interface

The Blue Heat/PCI RS-422/485; Opto; Opto RS-422/485 and Universal Blue Heat/PCI RS-422/485 adapters come with the RS-422/485 electrical line interface. The RS-422/485 electrical interface is a reliable high-speed serial link that offers superior noise immunity and multi-drop network connectivity. The RS-422/485 electrical interface is also a superset of the RS-422 electrical interface. These adapters offer full RS-422/485 support in hardware. The modes are as follows:

Full Duplex Mode

In this mode, TxD & RxD are active all the time. This mode is typically used in point to point situations much like RS-232. Please refer to [Appendix C: RS-422/485 Line Interface](#).

Half Duplex Mode

In this mode the TxD line driver is enabled only when data is transmitted and RxD is disabled when data is being transmitted. This mode is typically used in either point to point "2 wire" connections OR in multi-drop "2 wire" bus connections. Please refer to [Appendix C: RS-422/485 Line Interface](#).

Multi-drop Slave Mode

In this mode the TxD line driver is enabled only when data is transmitted and RxD is enabled all the time. This mode is typically used in multi-drop "4 wire" connections. Please refer to [Appendix C: RS-422/485 Line Interface](#).

20mA Current Loop Interface

The Blue Heat/PCI CL adapter comes with the 20mA Current Loop electrical line interface. The 20mA Current Loop electrical interface provides a reliable high-speed serial link over a long distance that offers superior noise immunity and multi-drop network connectivity. Please refer to [Appendix D: 20mA Current Loop Interface](#).

Software Installation

Introduction

Blue Heat/PCI boards are standard multi-port serial adapters that utilize 16C654, 16C864 or 16C2850 UARTS. In many cases, users have software that will interface directly to the Blue Heat/PCI boards. Many operating systems come with handlers to control access to multiple 8250 style UARTS. Blue Heat/PCI adapters currently ship with device drivers for the following operating systems:

- Linux
- QNX 4
- QNX 6
- SCO Unix/Openserver
- SCO UnixWare
- Solaris
- Windows 2000
- Windows 95/98/Me
- Windows CE
- Windows NT
- Windows XP
- Windows XP Professional x64

If you require further information please contact Connect Tech Customer Support.

Technical Tips:

Your Blue Heat/PCI adapter may ship with disks that include **howto.txt** or **readme.txt** files. Please examine these files for technical tips or release notes concerning installation and configuration of various device drivers and software utilities.

If you did not receive a driver diskette or CD for your operating system or you require additional information, please go to the [Download Zone](#) of the [Support Center](#) on the [Connect Tech](#) website for product manuals, installation guides, diagnostic utilities and device driver software.

Appendix A: Specifications

Operating Environment

- Storage temperature: -65° C - 150° C
- Operating temperature: 0° C to 70° C
- Relative humidity: 5 - 95% non-condensing
- Air movement: no requirement
- Altitude: 15,000 feet (5000 metres)

Power Requirements

- *Blue Heat/PCI (2 port model)*
 - +5 VDC +/-5% @ 200 mA (typical)
 - +/-12VDC+/-10% @ 20 mA (typical)
- *Blue Heat/PCI (4 port model)*
 - +5 VDC +/-5% @ 220 mA (typical)
 - +/-12VDC+/-10% @ 60 mA (typical)
- *Blue Heat/PCI (8 port model)*
 - +5 VDC +/-5% @ 320 mA (typical)
 - +/-12VDC+/-10% @ 120 mA (typical)
- *Blue Heat/PCI RS-422/485 (8 port model)*
 - +5 VDC ±5% @ 600mA
- *Blue Heat/PCI RS-422/485 (6+2 model)*
 - +5 VDC ±5% @ 500mA
- *Blue Heat/PCI RS-422/485 (4+4 model)*
 - +5 VDC ±5% @ 550mA
- *Blue Heat/PCI RS-422/485 (4 port model)*
 - +5 VDC ±5% @ 400mA
- *Blue Heat/PCI RS-422/485 (2+2 model)*
 - +5 VDC ± 5% @ 350mA
- *Blue Heat/PCI RS-422/485 (2 port model)*
 - +5 VDC ±5% @ 300mA
- *Blue Heat/PCI RJ-11*
 - +5 VDC ±5% @ 400mA (typical)
 - ±12 VDC ±10% @ 144mA (typical)
- *Blue Heat/PCI Opto; /PCI Opto RS-422/485 (2 port models)*
 - +5 VDC ±5% @ 320mA (typical)
- *Blue Heat/PCI Opto; /PCI Opto RS-422/485 (4 port models)*
 - +5 VDC ±5% @ 500mA (typical)
- *Blue Heat/PCI CL*
 - +5 VDC ±5% @ 375mA (typical)
 - ±12 VDC +/-10% 320mA (max.)
- *Universal Blue Heat/PCI RS-422/485 (4+4 model)*
 - +3 VDC ±5% @ 100mA (typical)
 - +5 VDC ±5% @ 340mA (typical)

Power Requirements (continued)

- Universal Blue Heat/PCI RS-422/485 (8 port model)
 - +3 VDC $\pm 5\%$ @ 100mA (typical)
 - +5 VDC $\pm 5\%$ @ 460mA (typical)

PCI Bus Interface

- One 32 bit, 5V PCI slot
- One 32 bit 3.3V or 5V PCI slot (Universal Blue Heat/PCI RS-422/485 adapters only)

Communications

- Communication controllers:
 - *Blue Heat/PCI; /PCI RJ-11; 20mA CL models:* 16C654 quad UARTs with 64 byte TxD/RxD FIFO buffers
 - *Blue Heat/PCI RS-422/485 models:* 16C864 quad UARTs with 128 byte TxD/RxD FIFO buffers
 - *Universal Blue Heat/PCI RS-422/485 models:* 16C864 quad UARTs with 128 byte TxD/RxD FIFO buffers
 - *Blue Heat/PCI Opto; Opto RS-422/485 models:* 16C2850 dual UARTs with 128 byte TxD/RxD FIFO buffers
- Programmable baud rate generator:
 - *Blue Heat/PCI; RJ-11 models:* 21 bps to 1382.4 Kbps on all ports
 - *Blue Heat/PCI RS-422/485; Opto; Opto RS-422/485; Universal Blue Heat/PCI RS-422/485 models:* 50 bps to 921.6 Kbps on all ports
 - *Blue Heat/PCI CL models:* 21 bps to 57.6 Kbps on all ports

Control Signals

- Blue Heat/PCI; RS-422/485; Universal Blue Heat/PCI RS-422/485 Models:
 - RS-232 RTS; DTR; TxD; DCD; CTS; RxD; DSR; RI
 - RS-422/485 RTS \pm ; TxD \pm ; CTS \pm ; RxD \pm
- Blue Heat/PCI RJ 11 Models:
 - RS-232
 - Ports 1 - 6: RTS; TxD; RxD; DSR; +5 VDC; +12 VDC
 - Ports 7, 8: DTR; DSR; RTS; CTS; RI; TxD; RxD; DCD
- Blue Heat/PCI Opto; Opto RS-422/485 Models:
 - RS-232 RTS; TxD; CTS; RxD
 - RS-422/485 RTS \pm ; TxD \pm ; CTS \pm ; RxD \pm

Control Signals (continued)

- Blue Heat/PCI CL Models:
 - 20mA TxD; RxD

Surge Suppression

- Blue Heat Models:
 - 500 watts, 8 x 20 μ S (EN61000-4-2/3/4 compatible) on every signal of every port.
- Blue Heat/PCI RS-422/485; Universal Blue Heat/PCI RS-422/485 Models:
 - TransGuard Transient Voltage Suppression, able to withstand multiple strikes on every signal of every port.
 - Transient Energy dissipation 0.1 joules on every signal of every port
 - Transient peak current dissipation 40A on every signal of every port
 - EN61000-4-2/3/4 compatible

Optical Isolation

- Blue Heat/PCI Opto; Opto RS-422/485 Models:
 - 1K or 2.5kV AC peak to peak on every signal of every port.

Dimensions

- Blue Heat/PCI (2, 4 & 8 port models)

Length:	12.25 cm	Width:	1.50 cm
Height:	10.50 cm	Weight:	0.12 kg
- Blue Heat/PCI RS-422/485 (8 port & 4+4 models)

Length:	17.30 cm	Width:	1.50 cm
Height:	10.50 cm	Weight:	0.20 kg
- Blue Heat/PCI RS-422/485 (6+2 model)

Length:	13.62 cm	Width:	1.50 cm
Height:	10.50 cm	Weight:	0.12 kg
- Blue Heat/PCI RS-422/485 (4 port & 2+2 models)

Length:	12.00 cm	Width:	1.50 cm
Height:	10.50 cm	Weight:	0.15 kg
- Blue Heat/PCI RS-422/485 (2 port model)

Length:	12.00 cm	Width:	1.50 cm
Height:	9.50 cm	Weight:	0.13 kg
- Blue Heat/PCI RJ-11

Length:	12.25 cm	Width:	1.12 cm
Height:	10.60 cm	Weight:	0.12 kg

Dimensions (continued)

- Blue Heat/PCI Opto; Opto RS-422/485 (2 & 4 port models)

Length:	19.50 cm	Width:	1.50 cm
Height:	9.50 cm	Weight:	0.12 kg

- Blue Heat/PCI 20mA CL

Length:	18.00 cm	Width:	1.50 cm
Height:	10.50 cm	Weight:	0.12 kg

- Universal Blue Heat/PCI RS-422/485

Length:	10.00 cm	Width:	1.50 cm
Height:	10.50 cm	Weight:	0.20 kg

Connectors/Interface

- Blue Heat/PCI; RS-422/485; 20mA CL; Universal Blue Heat/PCI RS-422/485; I/O Connector Box:
 - 9-pin male DB-9

- Blue Heat/PCI RJ-11:
 - 6-pin RJ-11 and optional 9-pin male DB-9

- Blue Heat/PCI Opto; Opto RS-422/485 and RJ-45 Plug:
 - 10-pin RJ-45; optional RJ-45 to male DB-9

Other connection options are available upon request. Contact Connect Tech for details.

Appendix B: Connectors/Pinouts

Appendix B outlines the pinouts for the following:

- Blue Heat/PCI; RS-422/485; Opto; Opto RS-422/485; RJ-11; 20mA CL and Universal Blue Heat/PCI RS-422/485 connector pinouts
- Blue Heat/PCI and RS-422/485 and CL and Universal Blue Heat/PCI RS-422/485 external connector box and RJ-45 Plug pinouts

Connector Pinouts

Tables 1 through 8 show the pinouts for the Blue Heat/PCI and RJ-11, RS-422/485, Opto, Opto RS-422/485, 20mA CL and Universal Blue Heat/PCI RS-422/485 connectors or cable connectors.

Note:

The port configuration on the Blue Heat/PCI RS-422/485 (6+2 model) is:

RS-232: Ports 1, 2, 3, 4, 5, 6
RS-422/485: Ports 7, 8

The port configuration on the Blue Heat/PCI RS-422/485 (4+4 model) and Universal Blue Heat/PCI RS-422/485 (4+4 model) is:

RS-232: Ports 1, 2, 3, 4
RS-422/485: Ports 5, 6, 7, 8

The port configuration on the Blue Heat/PCI RS-422/485 (2+2 model) is:

RS-232: Ports 1, 2
RS-422/485: Ports 3, 4

Technical Tip:

Please ensure that you terminate signals if your application does not use them. Failure to do so may result in a loss of a performance on your Blue Heat/PCI adapter.

Table 1: DB-9 pinouts for Blue Heat/PCI RS-232, 422/485 models, Universal Blue Heat/PCI RS-422/485

Pin No.	RS-232 Signal	Direction	RS-422/485 Signal	Direction
1	DCD	input	RxD B(+)	input
2	RxD	input	TxD B(+)	output
3	TxD	output	TxD A(-)	output
4	DTR	output	RxD A(-)	input
5	SG	signal gnd	SR	signal ref.
6	DSR	input	CTS A(-)	input
7	RTS	output	RTS A(-)	output
8	CTS	input	RTS B(+)	output
9	RI	input	CTS B(+)	input
Male DB-9 Connector				
				
Part #(s): CAB04DX CAB08FXDX				

Table 2: DB-9 pinouts for the Blue Heat/PCI Opto



Pin No.	RS-232 Signal	Direction	RS-422/485 Signal	Direction
1	N/C	no connect	RxD (+)	input
2	RxD	input	RxD (-)	input
3	TxD	output	TxD (+)	output
4	N/C	no connect	TxD (-)	output
5	SG	signal gnd	SR	signal ref.
6	N/C	no connect	CTS (-)	input
7	RTS	output	RTS (+)	output
8	CTS	input	CTS (+)	input
9	N/C	no connect	RTS (-)	output
Male DB-9 Connector				
				
Part #: CABRJ4509 Note: The RS-232 signals do not apply to the Blue Heat/PCI Opto RS-422/485 adapter.				

Table 3: RJ-45 pinouts for the Blue Heat/PCI Opto

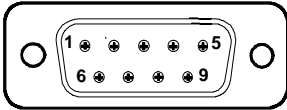
Pin No.	RS-232 Signal	Direction	RS-422/485 Signal	Direction
1	N/C	no connect	RTS (-)	output
2	N/C	input	RxD (+)	input
3	RTS	output	RTS (+)	output
4	SG	signal gnd	SR	signal ref.
5	TxD	output	TxD (+)	output
6	RxD	input	RxD (-)	input
7	Gnd	ground	Gnd.	ground
8	CTS	input	CTS (+)	input
9	N/C	no connect	TxD (-)	output
10	N/C	no connect	CTS (-)	input

RJ-45 connector

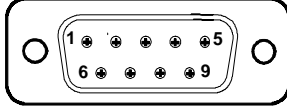

Note: The RS-232 signals do not apply to the Blue Heat/PCI Opto RS-422/485 adapter

Table 4: Blue Heat/PCI RJ-11 port header (P7/P8) pinouts

Pin No.	RS-232	Direction
1	DCD	input
2	DSR	input
3	RxD	input
4	RTS	output
5	TxD	output
6	CTS	input
7	DTR	output
8	RI	input
9	SG	signal gnd.
10	N/C	no connect

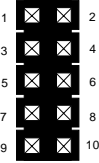

P7/P8

Table 5: Blue Heat/PCI RJ-11 pinouts

DB-9 Pin No.	RS-232 Signal	Direction	RJ-11 Pin No.	RS-232 Signal	Direction
1	DCD	input	1	RTS	output
2	RxD	input	2	RxD	input
3	TxD	output	3	TxD	output
4	DTR	output	4	DSR	input
5	SG	signal ground	5	SG	Signal/power ground
6	DSR	input	6	+12 VDC** or +5 VDC**	output
7	RTS	output			
8	CTS	input			
9	RI	input	** This option is a factory installed option		

Male DB-9 Connector

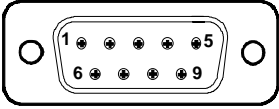

RJ-11 Connector

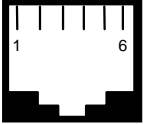

Part #: CAB104K
Technical Tip:
 Please ensure that you terminate the CTS signal if your application does not use them. The common way to do this is to connect CTS to RTS. Failure to do so may result in loss of a performance on your Blue Heat/PCI RJ-11 adapter.

Table 6: Blue Heat/PCI 20mA CL pinouts

Pin No.	20mA Signal	Direction
1	RxD(-)	input
2	TxD(+)	output
3	TxD Source	output
4	TxD Return	output
5	SG	signal ground
6	RxD Return	input
7	TxD(-)	output
8	RxD(+)	input
9	RxD Source	input

Male DB-9 Connector

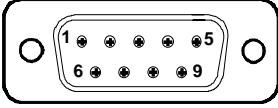

Part No.: CAB08FXDX

Table 7: DB-37 pinouts for Blue Heat/PCI RS-232 and RS-422/485 models

Pin No.	Port No.	RS-232 Signal	Direction	RS-422/485 Signal	Direction
1	1	SG	signal gnd	SR	signal ref
2	1	DTR	output	RxD A(-)	input
3	1	TxD	output	TxD A(-)	output
4	1	RxD	input	TxD B(+)	output
5	1	DCD	input	RxD B(+)	input
6		unused		unused	
7	3	RI	input	CTS B(+)	input
8	3	CTS	input	RTS B(+)	output
9	3	RTS	output	RTS A(-)	output
10	3	DSR	input	CTS A(-)	input
11	4	RI	input	CTS B(+)	input
12	4	CTS	input	RTS B(+)	output
13	4	RTS	output	RTS A(-)	output
14	4	DSR	input	CTS A(-)	input
15	2	SG	signal gnd	SR	signal ref
16	2	DTR	output	RxD A(-)	input
17	2	TxD	output	TxD A(-)	output
18	2	RxD	input	TxD B(+)	output
19	2	DCD	input	RxD B(+)	input
20	1	RI	input	CTS B(+)	input
21	1	CTS	input	RTS B(+)	output
22	1	RTS	output	RTS A(-)	output
23	1	DSR	input	CTS A(-)	input
24	3	SG	signal gnd	SR	signal ref
25	3	DTR	output	RxD A(-)	input
26	3	TxD	output	TxD A(-)	output
27	3	RxD	input	TxD B(+)	output
28	3	DCD	input	RxD B(+)	input
29	4	SG	signal gnd	SR	signal ref
30	4	DTR	output	RxD A(-)	input
31	4	TxD	output	TxD A(-)	output
32	4	RxD	input	TxD B(+)	output
33	4	DCD	input	RxD B(+)	input
34	2	RI	input	CTS B(+)	input
35	2	CTS	input	RTS B(+)	output
36	2	RTS	output	RTS A(-)	output
37	2	DSR	input	CTS A(-)	input
Part #: CAB04DX					

Table 8: DB-78 pinouts for Blue Heat/PCI RS-232, RS-422/485, Universal Blue Heat/PCI RS-422/485

Pin No.	Port No.	RS-232 Signal	Signal Direction	RS-422/485 Signal	Signal Direction	20mA	Signal Direction
1	5	RTS	output	RTS A(-)	output	TxD (-)	output
2	5	CTS	input	RTS B(+)	output	RxD (+)	input
3	5	DSR	input	CTS A(-)	input	RxD Ret.	input
4	5	RI	input	CTS B(+)	input	RxD Src.	input
5	5	SG	signal gnd.	SR	signal ref.	SG	signal ref
6	6	RTS	output	RTS A(-)	output	TxD (-)	output
7	6	CTS	input	RTS B(+)	output	RxD (+)	input
8	6	DSR	input	CTS A(-)	input	RxD Ret.	input
9	6	RI	input	CTS B(+)	input	RxD Src.	input
10	7	RTS	output	RTS A(-)	output	TxD (-)	output
11	7	CTS	input	RTS B(+)	output	RxD (+)	input
12	7	DSR	input	CTS A(-)	input	RxD Ret.	input
13	7	RI	input	CTS B(+)	input	RxD Src.	input
14	7	SG	signal gnd.	SR	signal ref.	SG	signal ref
15	8	RTS	output	RTS A(-)	output	TxD (-)	output
16	8	CTS	input	RTS B(+)	output	RxD (+)	input
17	8	DSR	input	CTS A(-)	input	RxD Ret.	input
18	8	RI	input	CTS B(+)	input	RxD Src.	input
19		NC	no connect	NC	no connect	NC	no connect
20		NC	no connect	NC	no connect	NC	no connect
21	5	TxD	output	TxD A(-)	output	TxD Src.	output
22	5	RxD	input	TxD B(+)	output	TxD (+)	output
23	5	DTR	output	RxD A(-)	input	TxD Ret.	output
24	5	DCD	input	RxD B(+)	input	RxD (-)	input
25	6	SG	signal gnd.	SR	signal ref.	SG	signal ref
26	6	TxD	output	TxD A(-)	output	TxD Src.	output
27	6	RxD	input	TxD B(+)	output	TxD (+)	output
28	6	DTR	output	RxD A(-)	input	TxD Ret.	output
29	6	DCD	input	RxD B(+)	input	RxD (-)	input
30	7	TxD	output	TxD A(-)	output	TxD Src.	output
31	7	RxD	input	TxD B(+)	output	TxD (+)	output
32	7	DTR	output	RxD A(-)	input	TxD Ret.	output
33	7	DCD	input	RxD B(+)	input	RxD (-)	input
34		SG	signal gnd.	NC	no connect	NC	no connect
35	8	TxD	output	TxD A(-)	output	TxD Src.	output
36	8	RxD	input	TxD B(+)	output	TxD (+)	output
37	8	DTR	output	RxD A(-)	input	TxD Ret.	output
38	8	DCD	input	RxD B(+)	input	RxD (-)	input
39	8	SG	signal gnd.	SR	signal ref.	SG	signal ref

...Continued on the next page

Table 8 (cont.): DB-78 pinouts – Blue Heat/PCI; RS-422/485; 20mA CL; Universal Blue Heat/PCI RS-422/485

Pin No.	Port No.	RS-232 Signal	Signal Direction	RS-422/485 Signal	Signal Direction	20mA	Signal Direction
40	1	RTS	output	RTS A(-)	output	TxD (-)	output
41	1	CTS	input	RTS B(+)	output	RxD (+)	input
42	1	DSR	input	CTS A(-)	input	RxD Ret.	input
43	1	RI	input	CTS B(+)	input	RxD Src.	input
44	1	SG	signal gnd.	SR	signal ref.	SG	signal ref
45	2	RTS	output	RTS A(-)	output	TxD (-)	output
46	2	CTS	input	RTS B(+)	output	RxD (+)	input
47	2	DSR	input	CTS A(-)	input	RxD Ret.	input
48	2	RI	input	CTS B(+)	input	RxD Src.	input
49	3	RTS	output	RTS A(-)	output	TxD (-)	output
50	3	CTS	input	RTS B(+)	output	RxD (+)	input
51	3	DSR	input	CTS A(-)	input	RxD Ret.	input
52	3	RI	input	CTS B(+)	input	RxD Src.	input
53	3	SG	signal gnd.	SR	signal ref.	SG	signal ref
54	4	RTS	output	RTS A(-)	output	TxD (-)	output
55	4	CTS	input	RTS B(+)	output	RxD (+)	input
56	4	DSR	input	CTS A(-)	input	RxD Ret.	input
57	4	RI	input	CTS B(+)	input	RxD Src.	input
58		NC	no connect	NC	no connect	NC	no connect
59		NC	no connect	NC	no connect	NC	no connect
60	1	TxD	output	TxD A(-)	output	TxD Src.	output
61	1	RxD	input	TxD B(+)	output	TxD (+)	output
62	1	DTR	output	RxD A(-)	input	TxD Ret.	output
63	1	DCD	input	RxD B(+)	input	RxD (-)	input
64	2	SG	signal gnd.	SR	signal ref.	SG	signal ref
65	2	TxD	output	TxD A(-)	output	TxD Src.	output
66	2	RxD	input	TxD B(+)	output	TxD (+)	output
67	2	DTR	output	RxD A(-)	input	TxD Ret.	output
68	2	DCD	input	RxD B(+)	input	RxD (-)	input
69	3	TxD	output	TxD A(-)	output	TxD Src.	output
70	3	RxD	input	TxD B(+)	output	TxD (+)	output
71	3	DTR	output	RxD A(-)	input	TxD Ret.	output
72	3	DCD	input	RxD B(+)	input	RxD (-)	input
73	4	SG	signal gnd.	SR	signal ref.	SG	signal ref.
74	4	TxD	output	TxD A(-)	output	TxD Src.	output
75	4	RxD	input	TxD B(+)	output	TxD (+)	output
76	4	DTR	output	RxD A(-)	input	TxD Ret.	output
77	4	DCD	input	RxD B(+)	input	RxD (-)	input
78		NC	no connect	NC	no connect	NC	no connect
Cable Part #(s): CAB08FXDX IOB08DB9 IOB08DB9V1							

Connector Box Pinouts

You may order the Blue Heat/PCI (8 port model), Blue Heat/PCI RS-422/485 (8 port, 4+4 and 6+2 models) and Blue Heat/PCI CL with an external I/O Box or the RJ-45 Connector Plug option. The I/O Box option comes with a metal bracket that can be mounted on a wall or other surface. When you receive the I/O Box, this bracket is clipped on to the back of the connector box. If you wish to attach the I/O Box to a wall or other surface, just remove the bracket, fasten it in place, and then re-attach the connector box. If you wish to set the I/O Box on its rubber feet only, just remove the bracket from the back. See [Figure 10](#) and [Figure 11](#) for the orientation of the I/O Box and RJ-45 Connector Plug and [Table 9](#) and [Table 10](#) for the DB-9 pinouts on the connector box and the RJ-45 pinouts on the plug.

Note:

The port configuration on the Blue Heat/PCI RS-422/485 (6+2 model) is:

RS-232: Ports 1, 2, 3, 4, 5, 6
RS-422/485: Ports 7, 8

The port configuration on the Blue Heat/PCI RS-422/485 (4+4 model) and Universal Blue Heat/PCI RS-422/485 (4+4 model) is:

RS-232: Ports 1, 2, 3, 4
RS-422/485: Ports 5, 6, 7, 8

The port configuration on the Blue Heat/PCI RS-422/485 (2+2 model) is:

RS-232: Ports 1, 2
RS-422/485: Ports 3, 4

Figure 10: Blue Heat/PCI, RS-422/485, 20mA CL and Universal Blue Heat/PCI RS-422/485 I/O Box

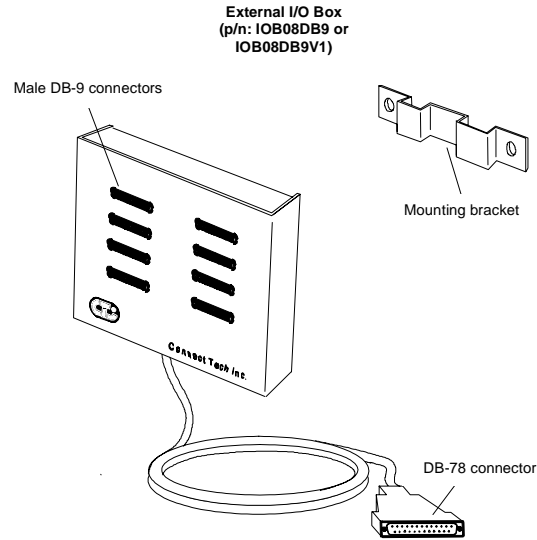

Table 9: DB-9 pinouts for Blue Heat/PCI RS-232, RS-422/485, 20mA CL and Universal Blue Heat/PCI RS-422/485 I/O Box

Pin No.	RS-232 Signal	Direction	RS-422/485 Signal	Direction	20mA	Direction
1	DCD	input	RxD B(+)	input	RxD(-)	input
2	RxD	input	TxD B(+)	output	TxD(+)	output
3	TxD	output	TxD A(-)	output	TxD Source	output
4	DTR	output	RxD A(-)	input	TxD Return	output
5	SG	signal gnd.	SR	signal ref.	SG	sig. gnd.
6	DSR	input	CTS A(-)	input	RxD Return	input
7	RTS	output	RTS A(-)	output	TxD(-)	output
8	CTS	Input	RTS B(+)	output	RxD(+)	input
9	RI	Input	CTS B(+)	input	RxD Source	input

Male DB-9 Connector

Figure 11: RJ-45 Connector Plug

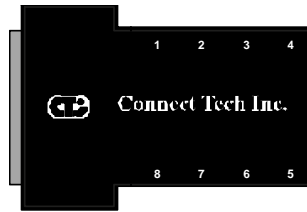

Table 10: RJ-45 pinouts, RJ-45 connector plug

Pin No.	RS-232 Signal	Direction	RS-422/485 Signal	Direction	20mA	Direction
1	RI	input	CTS (+)	input	RxD Source	input
2	DSR	input	CTS (-)	input	RxD Return	input
3	RTS	output	RTS (-)	output	TxD (-)	output
4	SG	signal gnd.	FG	frame gnd.	FG	frame gnd.
5	TxD	output	TxD (-)	output	TxD Source	output
6	RxD	input	TxD (+)	output	TxD (+)	output
7	Gnd	ground	Gnd	ground	Sig. Gnd.	signal gnd.
8	CTS	input	RTS (+)	output	RxD(+)	input
9	DTR	output	RxD (-)	input	TxD Return	output
10	DCD	input	RxD (+)	input	RxD (-)	input
<p>RJ-45 Connector</p>						

Appendix C: RS-422/485 Line Interface

For information on how to configure your RS-422/485 interface, find your specific Blue Heat/PCI model below:

Blue Heat/PCI RS-422/485

You can order the Blue Heat/PCI RS-422/485 adapter with all ports RS-422/485 or a combination of RS-422/485 and RS-232. The RS-422/485 electrical interface is a reliable high-speed serial link that offers superior noise immunity and multi-drop network connectivity. The RS-422/485 electrical interface is also a superset of the RS-422 electrical interface. The Blue Heat/PCI RS-422/485 offers full RS-422/485 support in hardware. The modes are as follows:

Full Duplex Mode

In this mode, TxD & RxD are active all the time. This mode is typically used in point to point situations much like RS-232.

Half Duplex Mode

In this mode the TxD line driver is enabled only when data is transmitted and RxD is disabled when data is being transmitted. This mode is typically used in either point to point "2 wire" connections OR in multi-drop "2 wire" bus connections.

Multi-drop Slave Mode

In this mode the TxD line driver is enabled only when data is transmitted and RxD is enabled all the time. This mode is typically used in multi-drop "4 wire" connections.

Line Bias/Termination

On the Blue Heat/PCI RS-422/485 the RS-422/485 receivers are biased high through fixed resistors. Please refer to [Figure 12](#) for a partial schematic.

Universal Blue Heat/PCI RS-422/485

Universal Blue Heat/PCI RS-422/485 adapters offer full RS-422/485 support in hardware like the other Blue Heat/PCI RS-422/485 models. The modes include full duplex, half duplex, and multi-drop slave. Universal Blue Heat/PCI RS-422/485 adapters offer the following additional functionality:

Tri-state Control

Universal Blue Heat/PCI RS-422/485 adapters allow you to tri-state the line drivers on power up. To tri-state the drivers on power up please ensure there is no jumper installed across the pins on jumper block J1. Refer to [Figure 3](#) for the location of J1.

Line Bias/Termination

On the Universal Blue Heat/PCI RS-422/485 the RS-422/485 receivers are biased high through fixed resistors. Please refer to [Figure 12](#) for a partial schematic.

Blue Heat/PCI RS-422/485 (6+2 model)

The Blue Heat/PCI RS-422/485 (6+2 model) offers full RS-422/485 support in hardware like the other Blue Heat/PCI RS-422/485 models. The modes include full duplex, half duplex, and multi-drop slave. The Blue Heat/PCI RS-422/485 (6+2 model) offers the following additional functionality.

Tri-state Control

The Blue Heat/PCI RS-422/485 6+2 model allows you to tri-state the line drivers on power up. To tri-state the drivers on power up please make certain there is no jumper installed across the pins on jumper block J1. Please refer to [Figure 4](#) for the location of J1.

Line Bias/Termination

You can use jumpers J2, J3, J4, J5, J6, J7, J8, J9, J10, J11, J12, and J13 to terminate and bias Tx \pm , Rx \pm , RTS \pm , and CTS \pm on the RS-422/485 ports 7 and 8. Please refer to [Figure 12](#) for a partial schematic of the RS-422/485 circuit for the Blue Heat/PCI RS-422/485 (6+2 model) and [Figure 4](#) for the location of J2, J3, J4, J5, J6, J7, J8, J9, J10, J11, J12, and J13.

Figure 12: Partial schematic: Blue Heat/PCI RS-422/485; Universal Blue Heat/PCI RS-422-485

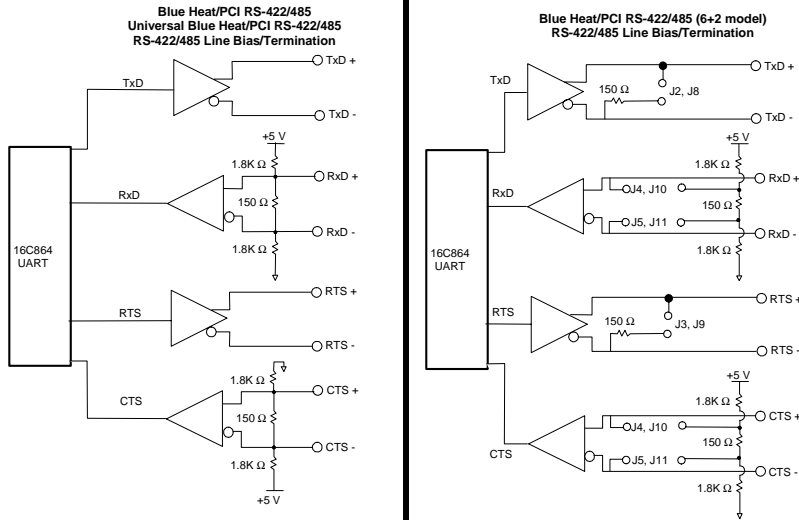

Note:

1. Line bias and termination is fixed and permanent.
2. Rx is biased inactive (off, idle)
3. CTS is biased active (on)
4. For custom line bias and termination requirements please contact a Connect Tech Sales Representative

Note:

1. Line bias and termination is jumper selectable for the Blue Heat/PCI RS-422/485 (6+2 model).

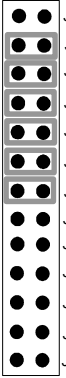
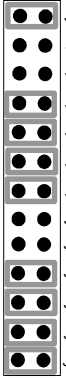
Example 1	Example 2
<p>The following example shows the settings on J1 to tri-state the line drivers upon power up of the Blue Heat/PCI RS-422/485 adapter (6+2 model). It also shows the settings on J2 through J13 where the RS-422/485 port 7 is set for termination on TxD, RTS and bias/termination on CTS ±, and RxD ±; the RS-422/485 port 8 is set for no bias/termination</p>	<p>The following example shows the settings on J1 to enable the RS-422/485 transmitters upon power up of the Blue Heat/PCI RS-422/485 adapter (6+2 model). It also shows the settings on J2 through J13 where the RS-422/485 ports 7 and 8 are set for no termination on TxD, RTS and bias/termination on CTS ±, and RxD ±</p>
 <p>Legend J1 = Tri-state control J2 = TxD termination port 7 J3 = RTS termination port 7 J4 = RxD + bias/termination port 7 J5 = RxD - bias/termination port 7 J6 = CTS + bias/termination port 7 J7 = CTS - bias/termination port 7 J8 = TxD termination port 8 J9 = RTS termination port 8 J10 = RxD + bias/termination port 8 J11 = RxD - bias/termination port 8 J12 = CTS + bias/termination port 8 J13 = CTS - bias/termination port 8</p>	 <p>Legend J1 = Tri-state control J2 = TxD termination port 7 J3 = RTS termination port 7 J4 = RxD + bias/termination port 7 J5 = RxD - bias/termination port 7 J6 = CTS + bias/termination port 7 J7 = CTS - bias/termination port 7 J8 = TxD termination port 8 J9 = RTS termination port 8 J10 = RxD + bias/termination port 8 J11 = RxD - bias/termination port 8 J12 = CTS + bias/termination port 8 J13 = CTS - bias/termination port 8</p>

Note:
 If you wish to bias/terminate CTS ± on a specific port, you must jumper both CTS ± positions on the appropriate jumper block.

If you wish to bias/terminate RxD ± on a specific port, you must jumper both RxD ± positions on the appropriate jumper block.

Blue Heat/PCI Opto and Opto RS-422/485

The Blue Heat/PCI Opto ships with all ports jumper selectable for RS-232 or RS-422/485. The Blue Heat/PCI Opto RS-422/485 ships with all ports RS-422/485 only. Both the Blue Heat/PCI Opto and the Blue Heat/PCI Opto RS-422/485 offer full RS-422/485 support in hardware with three modes: Full Duplex, Half Duplex, and Multi-drop Slave. You enable these modes via software. See the readme files for each operating system concerning details on how to enable the different modes

Electrical Interface Selection

The Blue Heat/PCI Opto adapter provides jumper selectable RS-232 and RS-422/485 electrical interfaces on each port.

Note:

Blue Heat/PCI Opto RS-422/485 adapters provide only an RS-422/485 electrical interface on each port. Jumper blocks J2, J3, J4 and J5 are not present, so therefore please disregard the following interface selection examples for Blue Heat/PCI Opto RS-422/485 adapters

Jumper blocks J2, J3, J4 and J5 set the electrical interfaces for the individual ports, with J2 for Port 1, J3 for Port 2, J4 for Port 3, and J5 for Port 4. Jumpers installed on J2, J3, J4 and J5 enable the RS-232 interface for that port, while jumpers not installed enable the RS-422/485 interface for that port. Figure 6 depicts the locations of jumper blocks J2, J3, J4 and J5.

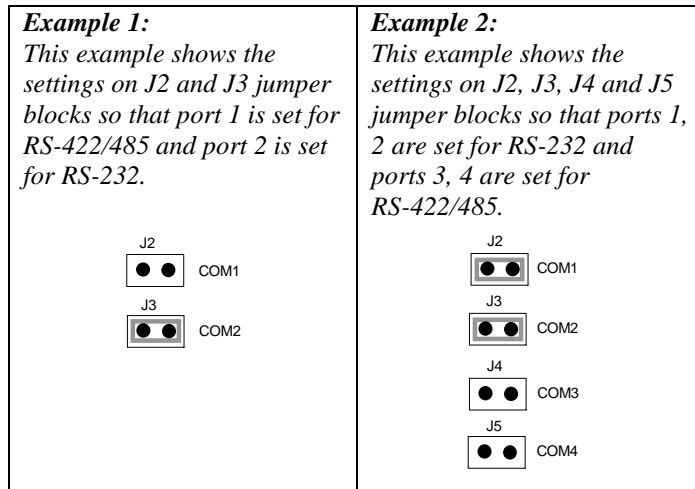

Technical Note:

You can set up the RS-232 serial ports to run at up to 230.4 Kbps, but you must use good quality cables to maintain high baud rates over longer distances.

Full Duplex Mode

In this mode, TxD & RxD are active all the time. This mode is typically used in point to point situations much like RS-232.

Half Duplex Mode

In this mode the TxD line driver is enabled only when data is transmitted and RxD is disabled when data is being transmitted. This mode is typically used in either point to point "2 wire" connections OR in multi-drop "2 wire" bus connections. To enable this mode for a port you must jumper positions 7 and 8 on the appropriate jumper blocks JA, JB, JC, JD. These jumpers short TxD – to RxD – and TxD + to RxD +. [Figure 6](#) depicts the locations of jumper blocks JA, JB, JC and JD.

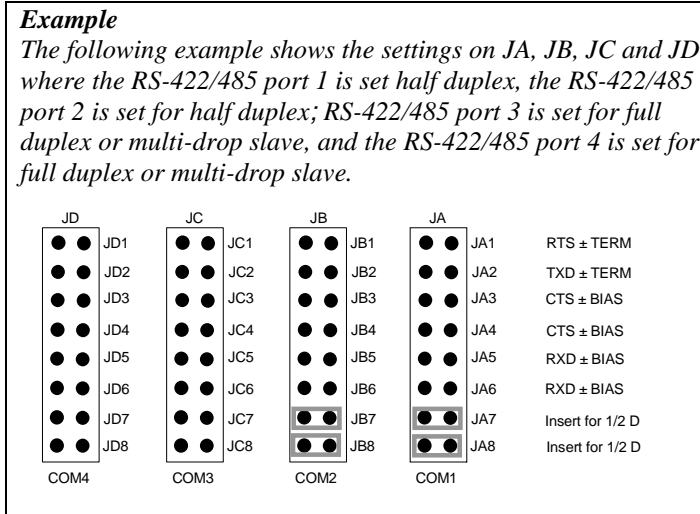

Technical Notes:
 If you wish to set a specific port for half duplex, you must jumper both positions 7 and 8 on the appropriate jumper block. For RS-232 ports do not jumper any positions on the appropriate JA, JB, JC and JD jumper block.

Multi-drop Slave Mode

In this mode the TxD line driver is enabled only when data is transmitted and RxD is enabled all the time. This mode is typically used in multi-drop "4 wire" connections.

Tri-state Control

The Blue Heat/PCI Opto adapters allow you to tri-state the line drivers on power up. To tri-state the drivers on power up please make certain there is no jumper installed across the pins on jumper block J1. Please refer to [Figure 6](#) for the location of J1.

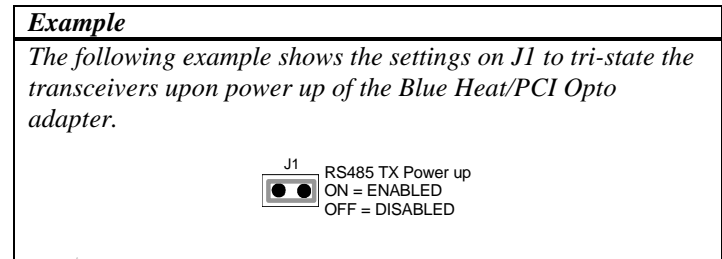

Line/Bias Termination

You can use jumper blocks JA, JB, JC and JD to terminate and bias TxD ±, RxD ±, RTS ±, and CTS ± on the individual RS-422/485 ports through jumper selectable 150 Ω fixed resistors.

Please refer to [Figure 13](#) for a partial schematic of the RS-422/485 circuit for the Blue Heat/PCI Opto and [Figure 6](#) for the locations of JA, JB, JC, and JD.

Figure 13: Partial schematic: Blue Heat/PCI Opto

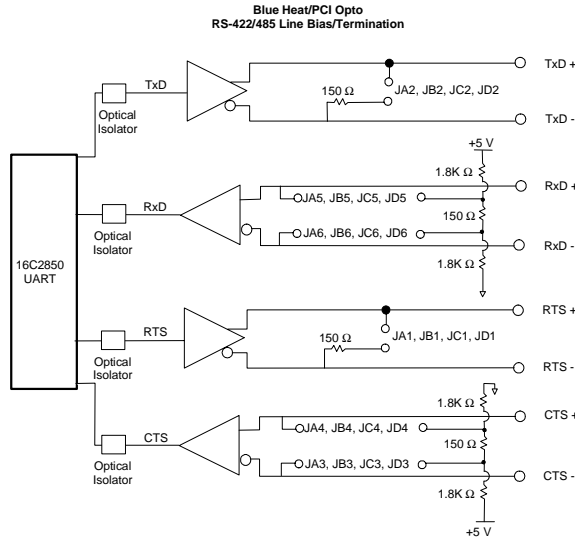

Note: Line bias/termination is jumper selectable

Example

The following example shows the settings on JA, JB, JC and JD where the RS-422/485 port 1 is set for bias/termination on CTS ±, and RxD ±; the RS-422/485 port 2 is set for bias/termination on RTS ±, TxD ±, CTS ±, and RxD ±; RS-422/485 port 3 is not terminated, and the RS-422/485 port 4 is not terminated

JD	JC	JB	JA	
● ● JD1	● ● JC1	● ● JB1	● ● JA1	RTS ± TERM
● ● JD2	● ● JC2	● ● JB2	● ● JA2	TXD ± TERM
● ● JD3	● ● JC3	● ● JB3	● ● JA3	CTS ± BIAS
● ● JD4	● ● JC4	● ● JB4	● ● JA4	CTS ± BIAS
● ● JD5	● ● JC5	● ● JB5	● ● JA5	RXD ± BIAS
● ● JD6	● ● JC6	● ● JB6	● ● JA6	RXD ± BIAS
● ● JD7	● ● JC7	● ● JB7	● ● JA7	
● ● JD8	● ● JC8	● ● JB8	● ● JA8	
COM4	COM3	COM2	COM1	

Technical Notes:
 If you wish to bias/terminate CTS ± on a specific port, you must jumper both CTS ± positions on the appropriate jumper block.
 If you wish to bias/terminate RxD ± on a specific port, you must jumper both RxD ± positions on the appropriate jumper block.

For RS-232 ports do not jumper any positions on the appropriate JA, JB, JC and JD jumper block.

RS-422/485 Cable Wiring

You can wire Blue Heat/PCI RS-422/485, Opto RS-422/485 and Universal Blue Heat/PCI RS-422/485 adapters in various ways to communicate with RS-422/485 peripherals. This section describes a few examples of RS-422/485 cabling schemes.

Figure 14 below describes a 4 wire cabling scheme between a port on the Blue Heat/PCI RS-422/485, Opto, Opto RS-422/485 or Universal Blue Heat/PCI RS-422/485 adapter to a port on the RS-422/485 peripheral.

Figure 14: RS-422/485 wiring diagram (4 wire)

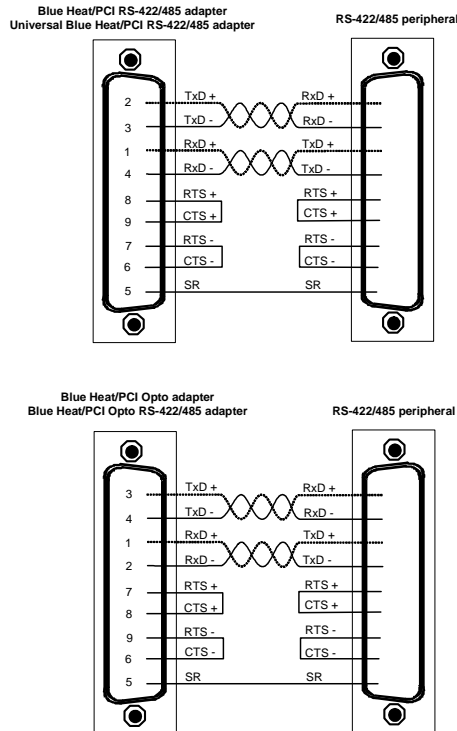

Technical Tip:
The RS-422/485 electrical interface consists of a differential signaling scheme. You should always connect the signals with twisted pairs.

Figure 15 below describes a 2 wire cabling scheme between a port on the Blue Heat/PCI RS-422/485, Opto, Opto RS-422/485 or Universal Blue Heat/PCI RS-422/485 adapter to a port on the RS-422/485 peripheral.

Figure 15: RS-422/485 wiring diagram (2 wire)

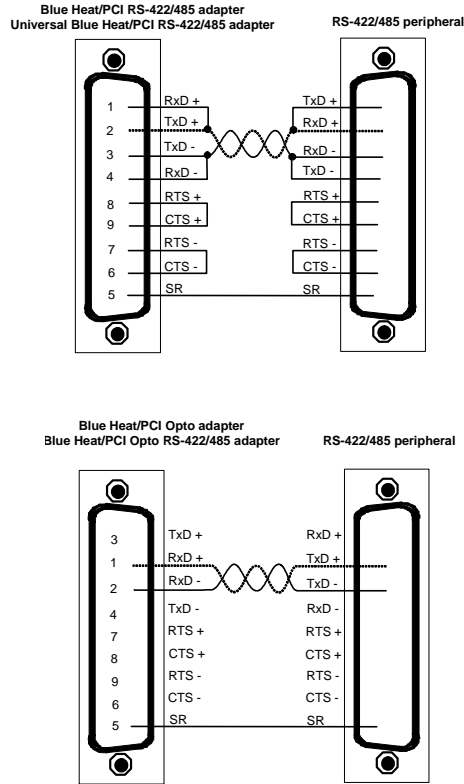

Note:
 In half-duplex mode it is assumed on the Blue Heat/PCI Opto adapter that TxD (-) is connected to RxD (-) and TxD (+) is connected to RxD (+) via jumpers JA7, JB7, JC7, JD7 and JA8, JB8, JC8, JD8.

Technical Tip:
 The RS-422/485 electrical interface consists of a differential signaling scheme. You should always connect the signals with twisted pairs.

Appendix D: 20mA Current Loop Line Interface

Blue Heat/PCI 20mA CL

The Blue Heat/PCI CL offers a 20mA Current Loop active or passive electrical interface. For each port there is an optically isolated receiver, an optically isolated transmitter and a 20mA current source. Optical isolation is functional in passive mode only. See [Figure 16](#) for the schematic of the 20mA Current Loop module.

Note: The current source uses a compliance voltage of 11 or 22 volts, and the transmitter will withstand a 27 volt drop. Please refer to the Hewlett Packard Optoelectronics Manual/Catalogue for a complete description of HPCL 4100 and HPCL 4200 specifications.

Figure 16: Partial schematic: Blue Heat/PCI 20mA CL

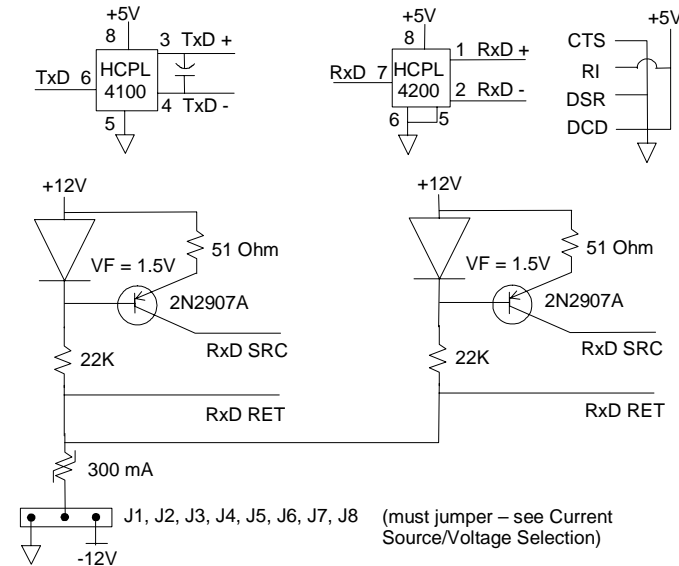

To implement an optically isolated passive interface, wire the transmitter and the receiver, while leaving the current sources unconnected. An external current source is required to implement a passive interface.

To implement an active interface, connect a 20mA current source in series with the transmitter and another 20mA current source in series with the receiver. Please refer to [Figure 17](#) for a 20mA Current Loop cable wiring configuration between one port of a Blue Heat/PCI CL adapter and another port of a Blue Heat/PCI CL adapter. This example shows wiring for both active and passive modes

Current Source/Voltage Selection

When using the current source in a loop with low resistance, the transistor will run hot. This can be avoided by increasing the loop resistance. The calculation for Maximum Loop Resistance(R_L) is:

$$\text{Max } R_L = \frac{V_S - (S \times V_D)}{0.020}$$

Where:

- $V_S = 22V$ when pins 2 and 3 on jumper blocks J1, J2, J3, J4 J5, J6, J7 or J8 are jumpered
- $V_S = 11V$ when pins 1 and 2 on jumper blocks J1, J2, J3, J4 J5, J6, J7 or J8 are jumpered
- S = the number of stations in the loop (TX's and RX's)
- V_D = the voltage drop for the HP opto couplers on the SLIM. $V_D = 2.3 V$ for the HPCL 4100 and HPCL 4200. When you use other manufacturers' equipment in the loop, the value of V_D may differ.

Note:

For most applications, jumpering pins 1 and 2 on the appropriate jumper block (J1, J2, J3, J4, J5, J6, J7 or J8) will be satisfactory.

Jumpering pins 2 and 3 on the appropriate jumper block (J1, J2, J3, J4, J5, J6, J7 or J8) may be required for applications with multiple/many loads on the Current Loop network.

J1, J2, J3, J4, J5, J6, J7, and J8 are factory set with no jumpers installed. (Please refer to [Figure 7](#) for the locations of J1, J2, J3, J4, J5, J6, J7, and J8)

Current Loop Cable Wiring

You can wire Blue Heat/PCI CL adapters in various ways to communicate with 20mA Current Loop peripherals. A few examples of Current Loop cabling schemes follow.

Figure 17 below depicts a 4 wire cabling scheme between a port on the Blue Heat/PCI CL adapter to another port on the Blue Heat/PCI CL adapter.

Figure 17: Current Loop wiring diagram (4 wire)

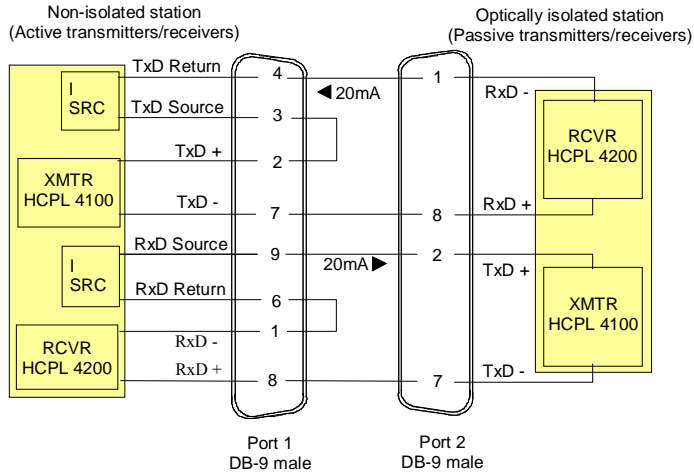

Note:
 The example above illustrates a 20mA Current Loop cable wiring configuration between one port of a Blue Heat/PCI CL adapter and another port of a Blue Heat/PCI CL adapter. This example shows wiring for both active and passive modes

Appendix E: Blue Heat/PCI PTM model

Blue Heat/PCI PTM Adapter

The Blue Heat/PCI Pass Through MUX (PTM) adapter offers two asynchronous RS-232 serial ports with **Pass-Through** and **Port-to-Connector** modes of operation.

Features

- Two, asynchronous RS-232 serial ports
- Supports data communications speeds up to 921 Kbps
- A 16C2850 UART controls each port providing 128 bytes of TxD/RxD FIFO buffers
- Independent port configuration with baud rates from 50 bps to 921 Kbps; data bits of 5, 6, 7 or 8; stop bits of 1, 1.5, or 2, and odd, even, or stick parity
- **Pass-Through** and **Port-to-Connector** modes (see descriptions below)
- Utilizes robust high quality Telecom DPDT relays to achieve pass-through mode
- Two onboard DB-9 connectors
- No DIP switches or jumpers to set – fully Plug and Play

Pass-Through Mode

In **Pass-Through** mode, the Blue Heat/PCI PTM adapter allows you to **pass through** data from a device connected to one serial (DB-9) connector to a device connected to the other serial (DB-9) connector. This data flow can be monitored via the Blue Heat/PCI PTM serial ports. Three conditions will cause the Blue Heat/PCI PTM to enter **Pass-Through** mode:

- Power to the computer fails (or is turned off intentionally).
- The software fails on the computer hosting the Blue Heat/PCI PTM.
- The software intentionally sets the adapter to **Pass-Through** mode.

Port-to-Connector Mode

In **Port-to-Connector** mode, each serial (DB-9) connector is attached to one of the serial ports on the adapter. You can process the serial data with your software as required for your application. The Blue Heat/PCI PTM adapter enters the **Port-to-Connector** mode when the application software provides periodic operation.

Software Application Operation

The driver supplied for your Operating System contains the necessary support to operate the PTM features of the Blue Heat/PCI. This support provides the following operations:

- **Heartbeat** operation which enables the **Port-to-Connector** mode for a period of time.
- **Heartbeat Timeout** setting which establishes the maximum time allowed between heartbeats.
- The ability to query the state of the relays
- **Auto Heartbeat** mode, in which the Blue Heat/PCI PTM issues its own heartbeat. This is useful for system testing or in situations where the application software supplied heartbeat is not practical.

Note: When the “Auto-Heartbeat” is used, the adapter cannot detect a software malfunction.

The heartbeat is a periodic event which holds the adapter in the **Port-to-Connector** mode. If the heartbeat fails to occur within the heartbeat timeout period, the adapter returns to the **Pass-Through** mode. Also, the software can also disable the heartbeat, which causes the adapter to immediately return to the **Pass-Through** mode.

The application software is responsible for establishing the heartbeat timeout and for providing the periodic heartbeat operation.

Figure 18: Blue Heat/PCI PTM adapter

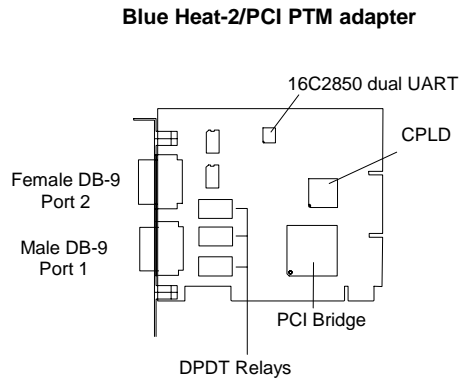

Specifications for the Blue Heat/PCI PTM

Power Requirements

- Blue Heat/PCI PTM
 - +5 VDC $\pm 5\%$ @ 360mA (typical)
 - ± 12 VDC $\pm 10\%$ @ 32mA (typical)

Communications

- Blue Heat/PCI PTM
 - Communication controllers:
 - 16C2850 dual UARTs with 128 byte TxD/RxD FIFO buffers
 - Programmable baud rate generator:
 - 50 BPS to 921.6 KBPS on all ports

Control Signals

- Blue Heat/PCI PTM
 - DTR; DSR; RTS; CTS; RI; TxD; RxD; DCD

Dimensions

- Blue Heat/PCI PTM
 - Length: 12.60 cm
 - Width: 10.70 cm
 - Height: 1.50 cm
 - Weight: 0.10 kg

Connectors/Interface

- Blue Heat/PCI PTM:
 - On board male and female DB-9 connectors

Certification

The Blue Heat/PCI PTM product family is to be included into a device ultimately subject to FCC, DOC/IC, and CE certification. The customer is responsible for bringing the completed device into compliance prior to resale.

Connect Tech has designed the Blue Heat/PCI PTM with EMI and EMC considerations such as:

- Ground and power planes
- Controlled slew-rate signals
- EMI/EMC reducing PCB layout

Connectors/Pinouts

Table 11 shows the pinouts for the Blue Heat/PCI PTM connectors. Figure 19 depicts the circuit connections on the Blue Heat/PTM for Pass-Through and Port-to-Connector modes.

Technical Tip:
Please ensure that you terminate signals if your application does not use them. Failure to do so may result in a loss of a performance on your Blue Heat/PCI PTM adapter.

Table 11: DB-9 pinouts – Blue Heat/PCI PTM

Male DB9 Pin No.	RS-232 Signal	Direction	FemaleDB-9 Pin No.	RS-232 Signal	Direction
1	DCD	input	1	DCD	input
2	RxD	input	2	TxD	output
3	TxD	output	3	RxD	input
4	DTR	output	4	DSR	input
5	SG	signal ground	5	SG	signal ground
6	DSR	input	6	DTR	output
7	RTS	output	7	CTS	input
8	CTS	input	8	RTS	output
9	RI	input	9	RI	input

 <p style="text-align: center; font-size: small;">Male DB-9 Connector</p>	 <p style="text-align: center; font-size: small;">Female DB-9 Connector</p>
--	---

Figure 19: Blue Heat/PCI PTM Connection Modes Diagram



In this diagram, relays are shown in **Pass-Through** mode. This mode occurs when the power is off, or there is no heartbeat. Signals are passed from one 9D connector to the other, and the communications between them can be monitored by Port 1 and Port 2.

When a heartbeat occurs with an interval less than the heartbeat timeout, the relays remain energized and thus function in the **Port-to-Connector** mode. In this case, signals from each port are routed to their respective connector.

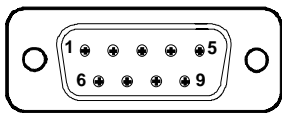
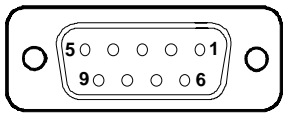
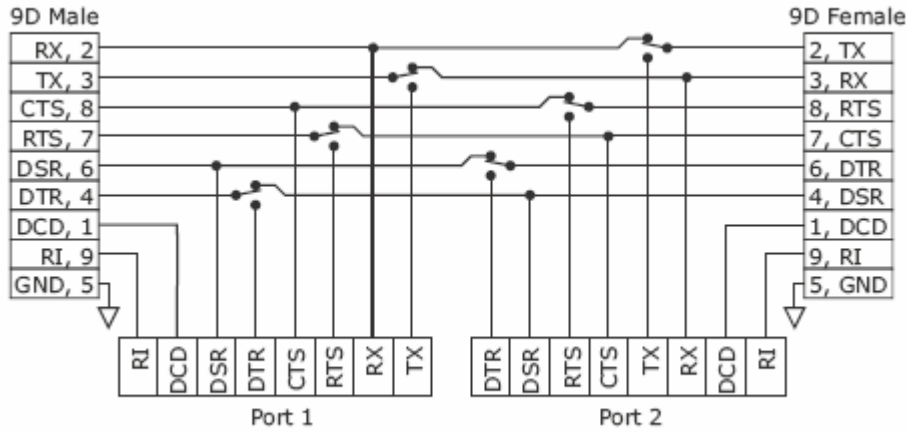
If the Pass-Through mode is software selected, or if the heartbeat interval is greater than the timeout, the relays return to Pass-Through mode.