



Connect Tech Inc.
Industrial Strength Communications

BlueStorm Universal PCI

User Manual



Contact Information:

Connect Tech Inc.
42 Arrow Road
Guelph, Ontario, Canada N1K 1S6

Tel: 519-836-1291 (International)
800-426-8979 (Canada & USA)

Fax: 519-836-4878

Email: sales@connecttech.com
support@connecttech.com

URL: www.connecttech.com

CTIM-00015 Revision 0.11 October 22, 2009

Limited Lifetime Warranty

Connect Tech Inc. provides a lifetime warranty for all* Connect Tech Inc. products. Should this product, in Connect Tech Inc.'s opinion, fail to be in good working order during the warranty period, Connect Tech Inc. will, at its option, repair or replace this product at no charge, provided that the product has not been subjected to abuse, misuse, accident, disaster or non Connect Tech Inc. authorized modification or repair.

You may obtain warranty service by delivering this product to an authorized Connect Tech Inc. business partner or to Connect Tech Inc. along with proof of purchase. Product returned to Connect Tech Inc. must be pre-authorized by Connect Tech Inc. with an RMA (Return Material Authorization) number marked on the outside of the package and sent prepaid, insured and packaged for safe shipment. Connect Tech Inc. will return this product by prepaid ground shipment service.

The Connect Tech Inc. lifetime warranty is defined as the serviceable life of the product. This is defined as the period during which all components are available. Should the product prove to be irreparable, Connect Tech Inc. reserves the right to substitute an equivalent product if available or to retract lifetime warranty if no replacement is available.

The above warranty is the only warranty authorized by Connect Tech Inc. Under no circumstances will Connect Tech Inc. be liable in any way for any damages, including any lost profits, lost savings or other incidental or consequential damages arising out of the use of, or inability to use, such product.

*Xtreme/104 Wireless Radio Modems include a one year warranty only.

Copyright Notice

The information contained in this document is subject to change without notice. Connect Tech Inc. shall not be liable for errors contained herein or for incidental consequential damages in connection with the furnishing, performance, or use of this material. This document contains proprietary information that is protected by copyright. All rights are reserved. No part of this document may be photocopied, reproduced, or translated to another language without the prior written consent of Connect Tech Inc.

Copyright © 1997 - 2008 by Connect Tech Inc.

Trademark Acknowledgment

Connect Tech Inc. acknowledges all trademarks, registered trademarks and/or copyrights referred to in this document as the property of their respective owners.

Not listing all possible trademarks or copyright acknowledgments does not constitute a lack of acknowledgment to the rightful owners of the trademarks and copyrights mentioned in this document.

Table of Contents

Limited Lifetime Warranty	2
Copyright Notice	2
Trademark Acknowledgment	2
Table of Contents	3
List of Figures	3
List of Tables	4
Customer Support Overview	5
Contact Information	5
Introduction	6
Features	6
BlueStorm Installation Overview	7
Hardware Configuration	7
Interrupts and Memory Address Selection	7
RS-422/485 Electrical Interface Configuration	7
Full Duplex Mode	7
Half Duplex Mode	7
Multi-drop Slave Mode	8
Line Bias/Termination	8
Jumper Block Diagrams for BlueStorm	8
Jumper Configuration for BlueStorm	11
TxD Control	12
RxD Control	12
RxD \pm Termination/Bias	12
TxD \pm Termination	12
Auto 485	12
Power-On Tri-state (BlueStorm/SP Models Only, Excludes BlueStorm/SP RJ-11)	13
Connectors and Pinouts	13
Hardware Installation	25
Software/Driver Installation	25
Specifications	25
Operating Environment	25
PCI Bus Interface	25
Communications	25
Baud Rates	25
UARTs	26
Surge Suppression	26
Optical Isolation	26
Dimensions	26
Certification	27

List of Figures

Figure 1: BlueStorm/LP Jumper Block Locations (2 Port Models)	8
Figure 2: BlueStorm/LP Jumper Block Locations (4 Port Models)	9
Figure 3: BlueStorm/LP Jumper Block Locations (8 Port Models)	9
Figure 4: BlueStorm/SP Jumper Block Locations (8 Port Models)	10
Figure 5: BlueStorm/SP Opto Jumper Block Locations (4 Port Models)	10
Figure 6: BlueStorm/SP RJ-11 (8 Port Model)	11
Figure 7: Jumper Configuration Example for 4 Port RS-422/485 BlueStorm/LP Models	12
Figure 8: Jumper Configuration Example for BlueStorm/SP Opto Models	12
Figure 9: Jumper Configuration Examples for BlueStorm/SP RJ-11 Models	12
Figure 10: BlueStorm External I/O Box Diagram	23
Figure 11: RS-422/485 Wiring Diagrams (BlueStorm/LP and BlueStorm/SP Only)	24
Figure 12: RS-422/485 Wiring Diagrams (BlueStorm/SP Opto Only)	24

List of Tables

Table 1: DB-25 Male Pinouts for BlueStorm/LP (2 Port Connector).....	13
Table 2: HDB-44 Pinouts for BlueStorm/LP (4 Port Connector).....	14
Table 3: VHDCI-68 Female Pinouts for BlueStorm/LP (8 Port Connector).....	16
Table 4: HDB-78 Pinouts for BlueStorm/SP (8 Port Connector).....	18
Table 5: RJ-45 Pinouts for BlueStorm/SP Opto (4 Port Connector).....	20
Table 6: Pinouts and Control Signals for DB-9 and DB-25 Male Connectors (BlueStorm/LP and BlueStorm/SP Only).....	21
Table 7: Pinouts and Control Signals for DB-9 Male Connectors (BlueStorm/SP Opto Only).....	21
Table 8: RJ-11 Pinouts for BlueStorm/SP RJ-11 (Ports 7 and 8 Only).....	22
Table 9: Pinouts and Control Signals for RJ-11 Connectors (BlueStorm/SP RJ-11 Only).....	22

Customer Support Overview

If you experience difficulties after reading the manual and/or using the product, contact the Connect Tech Inc. reseller from which you purchased the product. In most cases the reseller can help you with product installation and difficulties.

In the event that the reseller is unable to resolve your problem, our highly qualified support staff can assist you. Our support section is available 24 hours a day, 7 days a week on our website at: www.connecttech.com/sub/support/support.asp. See the contact information section below for more information on how to contact us directly. Our technical support is always free.

Contact Information

We offer three ways for you to contact us:

Mail/Courier

You may contact us by letter at:
Connect Tech Inc.
Technical Support
42 Arrow Road
Guelph, Ontario
Canada N1K 1S6

Email/Internet

You may contact us through the Internet. Our email and URL addresses on the Internet are:

sales@connecttech.com
support@connecttech.com
www.connecttech.com

Note:

Please go to the [Download Zone](#) or the [Knowledge Database](#) in the [Support Center](#) on the Connect Tech website for product manuals, installation guides, device driver software and technical tips.

Submit your technical support questions to our customer support engineers via the [Support Center](#) on the Connect Tech website.

Telephone/Facsimile

Technical Support representatives are ready to answer your call Monday through Friday, from 8:30 a.m. to 5:00 p.m. Eastern Standard Time. Our numbers for calls are:

Telephone: 800-426-8979 (North America only)
Telephone: 519-836-1291 (Live assistance available 8:30 a.m. to 5:00 p.m. EST
Monday to Friday)
Facsimile: 519-836-4878 (on-line 24 hours)

Introduction

Connect Tech Inc. presents BlueStorm/LP/SP/SP Opto and SP RJ-11. These high-speed multi-port communication adapters are designed for Low Profile (LP) and Standard Profile (SP) PCI compatible computers. BlueStorm cards provide you with up to eight high performance serial ports and baud rates up to 1.8432 Mbps that are compatible with any standard serial communications application.

BlueStorm cards are fully PCI compliant. Simply install your card into an available PCI slot in your computer and with Plug and Play installation and the hardware setup is complete.

BlueStorm cards are an ideal solution for multi-port serial communications in applications such as Point of Sale; Industrial Process Control, Office Automation and Data/Telecommunications. They allow easy attachment of peripherals such as barcode scanners, receipt printers, card readers, testing and monitoring equipment, modems, printers and any other device requiring serial communications.

Features

- Two, four or eight high performance asynchronous serial ports in various RS-232 and/or RS-422/485 electrical interface configurations.
- Baud rates up to 921.6 Kbps (RS-232) and 1.8432 Mbps (RS-422/485) using PCI UARTs with 64 bytes of TxD/RxD FIFO buffers.
- Support for three RS-422/485 modes: full duplex, half duplex and multi-drop slave.
- Each port can be configured independently (baud rate, parity, data and stop bits).
- DB-9 male fan-out cable (custom cable solutions also offered).
- Six RJ-11 connectors provide +12 VDC or +5 VDC output on pin 6 with a current limit of 300 mA (BlueStorm/SP RJ-11 model only).
- Optional multi-strike surge suppression on all signals, all ports (select models only).
- PCI compliant - with Plug and Play installation.
- QNX 4.X/6.X, Windows 2000/CE/NT/XP/XPe/XP 64-Bit/Server 2003/Server 2003 64-Bit, Vista, VxWorks, Ardence RTX and Linux compatible (contact Connect Tech for most current list)

Your BlueStorm product consists of the following components:

- A BlueStorm adapter
- An additional low/standard height chassis bracket (available on LP models only)
- One of the following; DB-9 fan-out cable, approximately 12 in./30.5 cm long, a DB-9 external I/O box , approximately 4ft./122 cm long, or a DB-25 fan-out cable, approximately 12in./30 cm long (optional)
- BlueStorm device drivers and documentation CD

BlueStorm Installation Overview

There are three stages to installing your BlueStorm card:

1. [Hardware Configuration](#)
Interrupts and Memory selection will be set by the host computer's BIOS and operating system. This section outlines jumper settings and configuration.
2. [Hardware Installation](#)
Installation involves the physical installation of the BlueStorm into your computer. Please note that you should configure any jumper settings prior to installing the board.
3. [Software/Driver Installation](#)
Load the appropriate driver for your Operating System, as found on the accompanying CD. Installation guides are also available on the CD to aid you in this process.

Hardware Configuration

Interrupts and Memory Address Selection

All BlueStorm products are PCI cards. Therefore, the host computer's BIOS will automatically set interrupts and memory addresses when you reboot after installation.

RS-422/485 Electrical Interface Configuration

Some BlueStorm adapters support RS-422/485 communication, as outlined below. (See Figure 1 through to Figure 6 for configuration jumper block locations). It may be necessary to configure the card to match your particular wiring configuration. Please see the "Jumper Configuration for BlueStorm" section below for configuration examples.

Full Duplex Mode

In this mode, TxD+/- and RxD+/- are being driven to a known level at all times. This mode is typically used in point-to-point situations much like RS-232.

Half Duplex Mode

In this mode the TxD+/- line driver is enabled only when data is transmitted and RxD+/- is disabled when data is being transmitted. This mode is typically used in either point-to-point 2-wire connections OR in multi-drop 2-wire bus connections. This mode requires software setup in **Control Panel – System – Hardware – Device Manager – Ports – CTI PCI UART**. Click on **Advanced** under **Port Settings** after the driver is installed. (See multi-drop slave below).

Multi-drop Slave Mode

In this mode the TxD+/- line driver is enabled only when data is transmitted and RxD+/- is enabled at all times. This mode is typically used in multi-drop 4-wire connections. This mode requires software setup in **Control Panel – System Properties – Hardware - Device Manager – Ports – CTI PCI UART**. Click on **Advanced** under **Port Settings**.

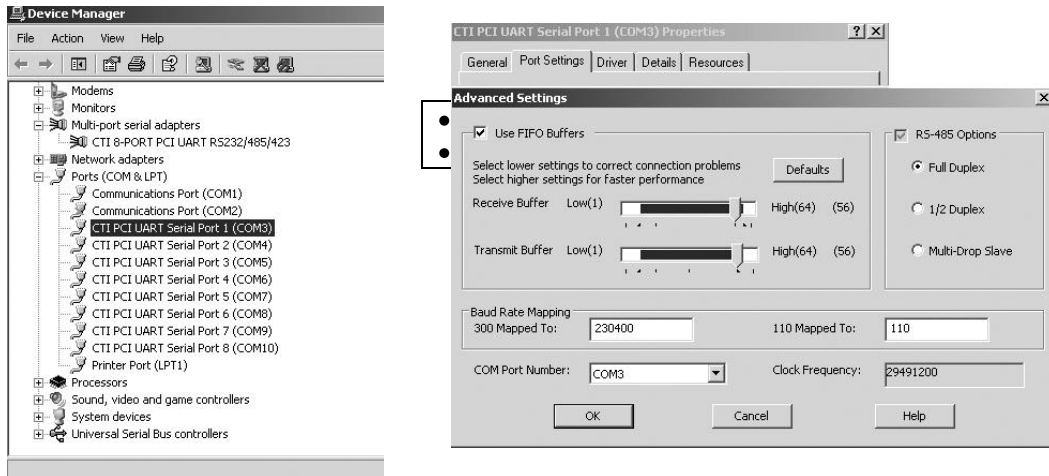

Line Bias/Termination

Jx1 Jx2 Jx3 Jx4 Jx5 Jx6

The RS-422/485 transceivers, both transmit and receive are optionally biased to produce a line level mark condition through jumper selectable resistors. These options are typically used in multi-drop 4-wire connections. Termination may also be required depending on your wiring configuration. Each case must be evaluated to determine which options to enable.

Jumper Block Diagrams for BlueStorm

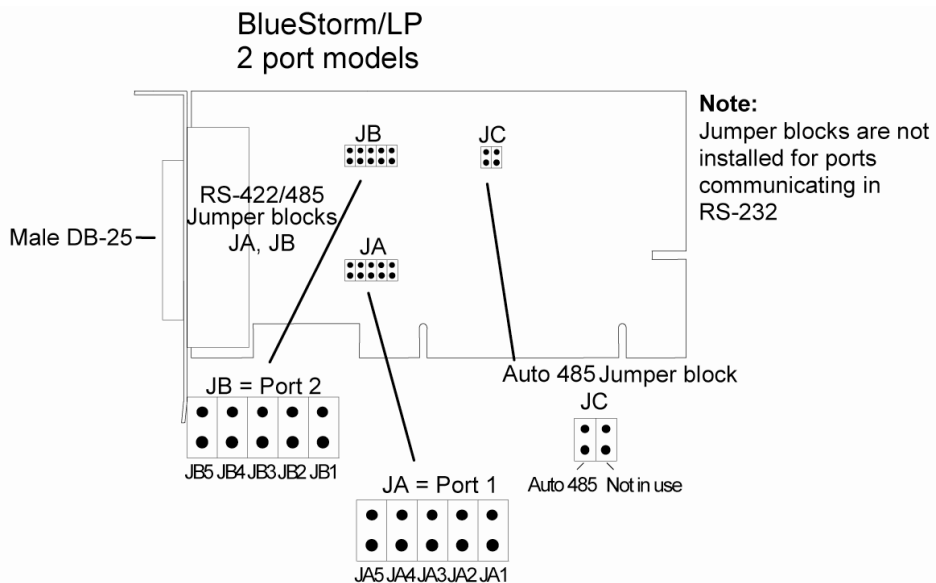

Figure 1: BlueStorm/LP Jumper Block Locations (2 Port Models)

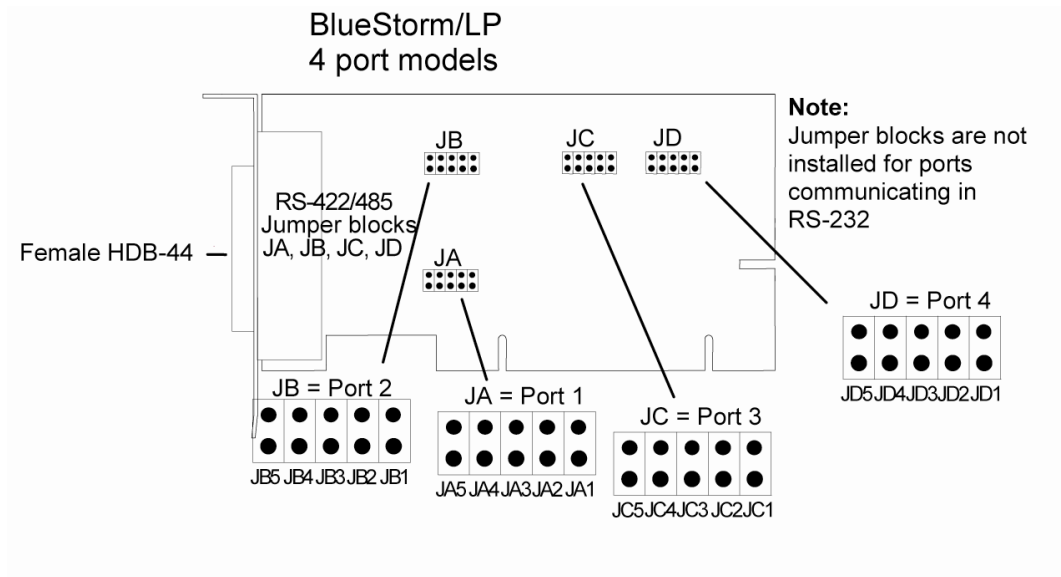

Figure 2: BlueStorm/LP Jumper Block Locations (4 Port Models)

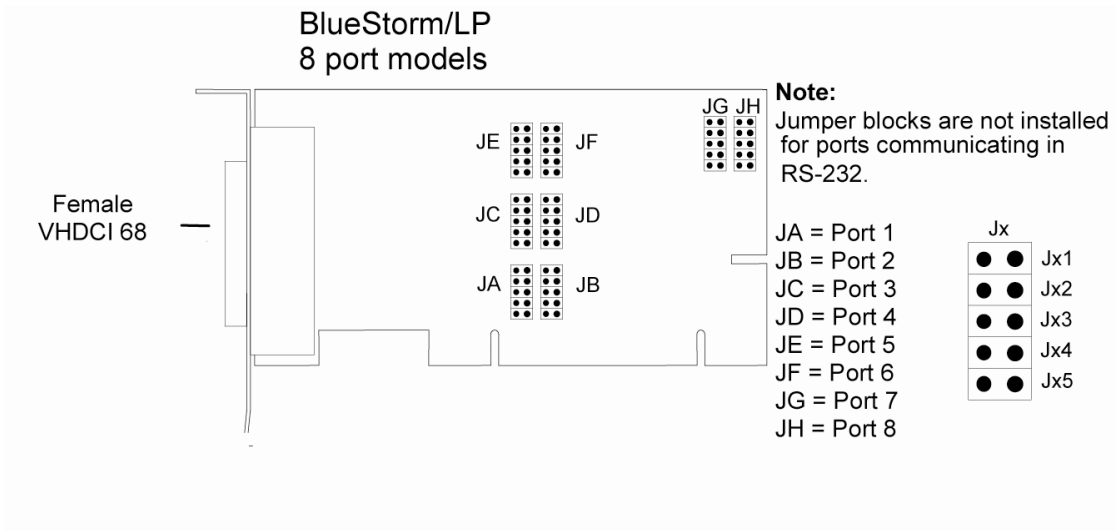

Figure 3: BlueStorm/LP Jumper Block Locations (8 Port Models)

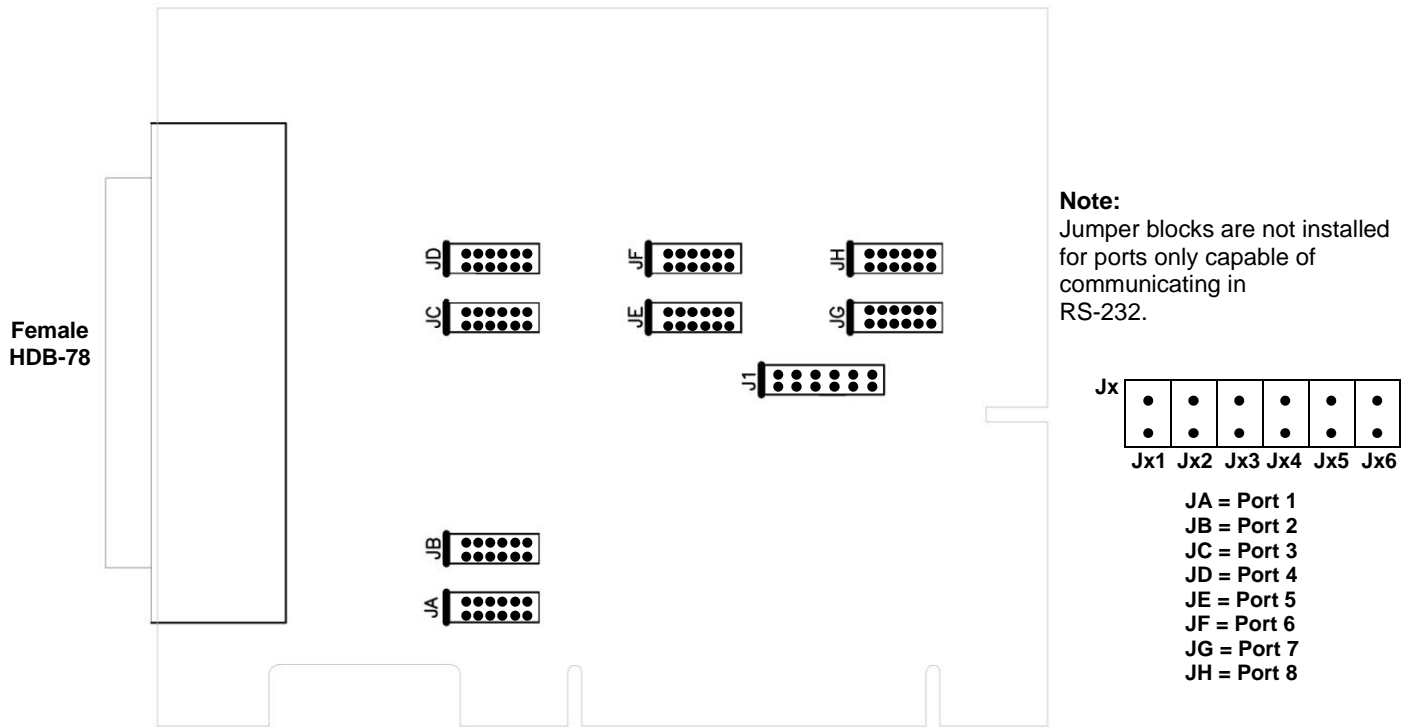

Figure 4: BlueStorm/SP Jumper Block Locations (8 Port Models)

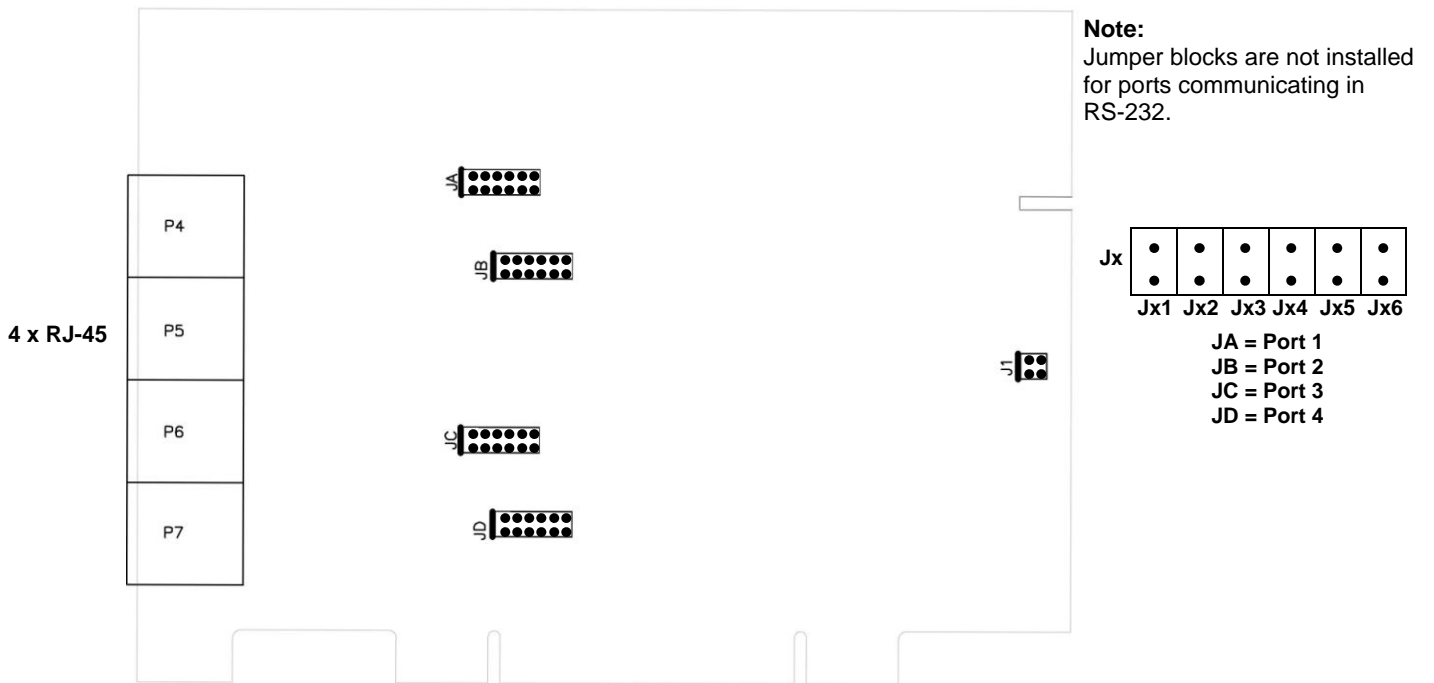

Figure 5: BlueStorm/SP Opto Jumper Block Locations (4 Port Models)

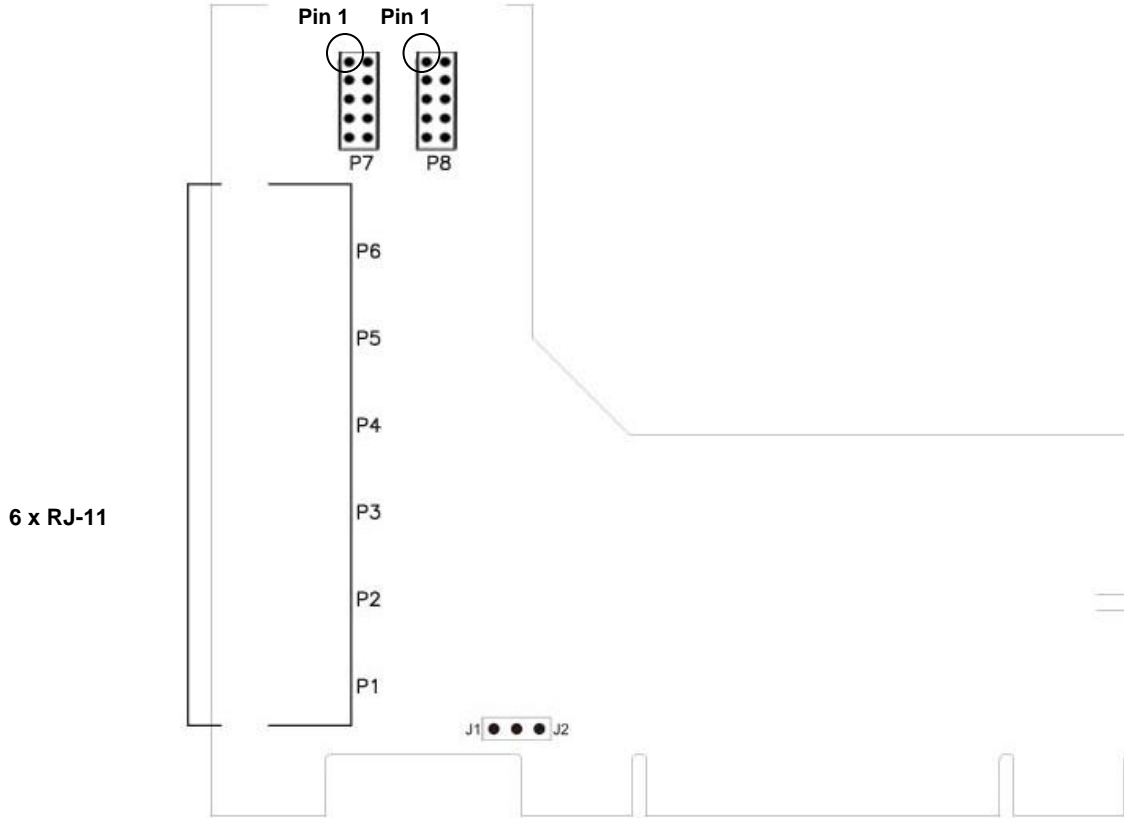

Figure 6: BlueStorm/SP RJ-11 (8 Port Model)

Note: Refer to [Table 8](#) for port 7 and port 8 pinouts.

Jumper Configuration for BlueStorm

Jumper configuration options will vary by model. BlueStorm/LP RS-422/485 cards feature the jumper layout listed in [Figure 7](#), while BlueStorm/SP and BlueStorm/SP Opto cards use the jumper layout in [Figure 8](#). Lastly, BlueStorm/SP RJ-11 uses the jumper layout used in [Figure 9](#). BlueStorm ports and cards that communicate only in RS-232 modes do not have jumper blocks installed.

[Figure 7](#) demonstrates a common set of jumper configurations for a BlueStorm/LP RS-422/485 card. BlueStorm/LP RS-232 ports do not require jumper configuration. The four RS-422/485 ports are set as follows: Port 1 is set for half duplex, Port 2 is set for half duplex, Port 3 is set for full duplex and Port 4 is set for multi-drop slave.

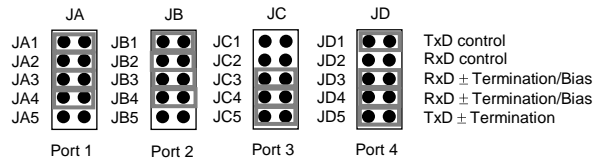

Figure 7: Jumper Configuration Example for 4 Port RS-422/485 BlueStorm/LP Models

[Figure 8](#) indicates a common set of jumper configurations for BlueStorm/SP and BlueStorm/SP Opto. The four ports are set as follows: Port 1 is set for RS-232, Port 2 is set for half duplex, Port 3 is set for full duplex and Port 4 is set for multi-drop slave.

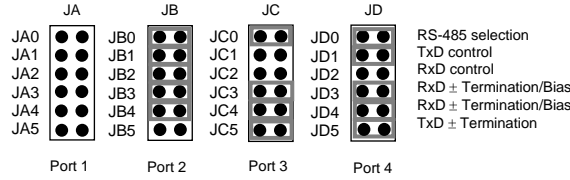

Figure 8: Jumper Configuration Example for BlueStorm/SP Opto Models

[Figure 9](#) illustrates the jumper configurations for selecting +5V power or +12V power.

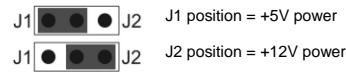

Figure 9: Jumper Configuration Examples for BlueStorm/SP RJ-11 Models

TxD Control

Install this jumper to enable the RS-485 transmitter only when sending data. This mode is useful for multi-drop and half-duplex operation when only one device is allowed to send data at a time. If the jumper is not installed, the transmitter will always drive the line to an idle state when not sending data.

RxD Control

Install this jumper to enable the RS-485 receiver only when NOT transmitting data. This is useful for two-wire half-duplex operation to prevent the transmitting device from receiving its own data as it sends. If this jumper is not installed, the receiver is always enabled and ready to receive data.

RxD ± Termination/Bias

Install this pair of jumpers to enable a 120 or 150 ohm terminator (model dependent) across the RxD+ and RxD- pins for the corresponding port. A biasing network is also enabled that drives the receiver to an inactive or safe mode. The receiver can still receive data from another device and the biasing helps to prevent the reception of data generated by noise on the transmission line. The two jumpers for RxD termination/bias must be installed and removed as a pair.

TxD ± Termination

Install this jumper to enable a 120 or 150 ohm resistor (model dependent) across the TxD+ and TxD- pins of the corresponding port.

Auto 485 (BlueStorm/LP 2 port RS-422/485 models and BlueStorm/SP Opto models only)

Install this jumper to tri-state the transmitters of ports configured as RS-485 half duplex or multi-drop slave when the computer powers up or is reset. This jumper will be overridden once the operating system is booted by the current driver/software RS-485 mode. The jumper is used to ensure that a port will power-on tri-stated. For example, the RS-485 mode selection in the Windows control panel will override this jumper setting once a port is opened.

The BlueStorm/LP RS-422/485 uses JC to configure Auto-485 mode, while the BlueStorm/SP Opto uses J1.

Note that on BlueStorm/LP RS-422/485 models the Auto 485 is a single jumper. The second site is not in use. See [Figure 1](#) for the location of this jumper. On the BlueStorm/SP Opto, the first position controls the first port pair, while the second position controls the second port pair.

Power-On Tri-state (BlueStorm/SP Models Only, Excludes BlueStorm/SP RJ-11)

BlueStorm/SP models offer a power-on tri-state similar to the Auto-485 mode listed above. The BlueStorm/SP will tri-state a port configured as RS-485 full duplex or RS-485 multi-drop slave. This is meant to ensure compatibility with our legacy Blue Heat/PCI cards for customers upgrading to the newer BlueStorm family.

Jumper J1 controls the power-on tri-state functionality. Install a jumper on the first location of the J1 in order to tri-state Port 1 at power-on, install a jumper on the second position of J1 to control Port 2, etc. Ports will not come out of tri-state until the driver opens the associated port and begins transmission.

[Half Duplex](#) and [Multi-drop Slave](#) modes require you to select the appropriate mode via software. Please refer to the `readme.txt` files found in the appropriate directories on the BlueStorm/LP/SP/SP Opto CD.

Connectors and Pinouts

Table 1: DB-25 Male Pinouts for BlueStorm/LP (2 Port Connector)

Pin No.	Port No.	RS-232 Signal	Signal Direction	RS-422/485 Signal	Signal Direction
1	2	SG	signal gnd.	SR	signal ref.
2	1	TXD	output	TXD-	output
3	1	RXD	input	TXD+	output
4	1	RTS	output	RTS-	output
5	1	CTS	input	RTS+	output
6	1	DSR	input	CTS-	input
7	1	SG	signal gnd.	SR	signal ref.
8	1	DCD	input	RXD+	input
9	2	TXD	output	TXD-	output
10	2	RXD	input	TXD+	output
11	2	RTS	output	RTS-	output
12	2	CTS	input	RTS+	output
13	2	DSR	input	CTS-	input
14		NC	no connect	NC	no connect
15		NC	no connect	NC	no connect
16		NC	no connect	NC	no connect
17		NC	no connect	NC	no connect
18		NC	no connect	NC	no connect
19	2	DTR	output	RXD-	input
20	1	DTR	output	RXD-	input
21		NC	no connect	NC	no connect

22	1	RI	input	CTS+	input
23	2	RI	input	CTS+	input
24		NC	no connect	NC	no connect
25	2	DCD	input	RXD+	input

Cable CBG002 sends the signals to two DB-9 male connectors. See [Table 6](#) for pinout details.
NOTE: This is not the pinout of DB-25 cable CBG007.

Table 2: HDB-44 Pinouts for BlueStorm/LP (4 Port Connector)

Pin No.	Port No.	RS-232 Signal	Signal Direction	RS-422/485 Signal	Signal Direction
1	1	TXD	output	TXD-	output
2	1	RTS	output	RTS-	output
3	1	DCD	input	RXD+	input
4	1	RXD	input	TXD+	output
5	2	TXD	output	TXD-	output
6	2	RTS	output	RTS-	output
7	2	DCD	input	RXD+	input
8	2	RXD	input	TXD+	output
9	3	TXD	output	TXD-	output
10	3	RTS	output	RTS-	output
11	3	DCD	input	RXD+	input
12	3	RXD	input	TXD+	output
13	4	TXD	output	TXD-	output
14	4	RTS	output	RTS-	output
15	4	DCD	input	RXD+	input
16	1	CTS	input	RTS+	output
17	1	SG	signal gnd.	SR	signal ref.
18		NC	no connect	NC	no connect
19		NC	no connect	NC	no connect
20	2	CTS	input	RTS+	output
21	2	SG	signal gnd.	SR	signal ref.
22		NC	no connect	NC	no connect
23	3	CTS	input	RTS+	output
24	3	SG	signal gnd.	SR	signal ref.
25		NC	no connect	NC	no connect
26		NC	no connect	NC	no connect
27	4	CTS	input	RTS+	output
28	4	SG	signal gnd.	SR	signal ref.
29		NC	no connect	NC	no connect
30	4	RXD	input	TXD+	output
31	1	DSR	input	CTS-	input
32	1	DTR	output	RXD-	input
33	1	RI	input	CTS+	input
34		NC	no connect	NC	no connect
35	2	DSR	input	CTS-	input
36	2	DTR	output	RXD-	input
37	2	RI	input	CTS+	input
38		NC	no connect	NC	no connect
39	3	DSR	input	CTS-	input
40	3	DTR	output	RXD-	input

41	3	RI	input	CTS+	input
42	4	DSR	input	CTS-	input
43	4	DTR	output	RXD-	input
44	4	RI	input	CTS+	input

Cable CBG003 sends the signals to four DB-9 male connectors. Cable CBG007 sends the signals to four DB-25 connectors. See [Table 6](#) for pinout details.

Table 3: VHDCI-68 Female Pinouts for BlueStorm/LP (8 Port Connector)

Pin No.	Port No.	RS-232 Signal	Signal Direction	RS-422/485 Signal	Signal Direction
1	1	TXD	output	TXD-	output
2	1	RI	input	CTS+	input
3	1	DCD	input	RXD+	input
4	1	DTR	output	RXD-	input
5	1	RTS	output	RTS-	output
6	1	DSR	input	CTS-	input
7	1	RXD	input	TXD+	output
8	1	CTS	input	RTS+	output
9	2	TXD	output	TXD-	output
10	2	RI	input	CTS+	input
11	2	DCD	input	RXD+	input
12	2	DTR	output	RXD-	input
13	2	RTS	output	RTS-	output
14	2	DSR	input	CTS-	input
15	2	RXD	input	TXD+	output
16	2	CTS	input	RTS+	output
17	1, 2	SG	signal gnd.	SR	signal ref.
18	3, 4	SG	signal gnd.	SR	signal ref.
19	3	TXD	output	TXD-	output
20	3	RI	input	CTS+	input
21	3	DCD	input	RXD+	input
22	3	DTR	output	RXD-	input
23	3	RTS	output	RTS-	output
24	3	DSR	input	CTS-	input
25	3	RXD	input	TXD+	output
26	3	CTS	input	RTS+	output
27	4	TXD	output	TXD-	output
28	4	RI	input	CTS+	input
29	4	DCD	input	RXD+	input
30	4	DTR	output	RXD-	input
31	4	RTS	output	RTS-	output
32	4	DSR	input	CTS-	input
33	4	RXD	input	TXD+	output
34	4	CTS	input	RTS+	output
35	5	TXD	output	TXD-	output
36	5	RI	input	CTS+	input
37	5	DCD	input	RXD+	input
38	5	DTR	output	RXD-	input
39	5	RTS	output	RTS-	output
40	5	DSR	input	CTS-	input
41	5	RXD	input	TXD+	output
42	5	CTS	input	RTS+	output
43	6	TXD	output	TXD-	output
44	6	RI	input	CTS+	input
45	6	DCD	input	RXD+	input
46	6	DTR	output	RXD-	input

...Continued on next page

Table 3: VHDCI-68 Female Pinouts for BlueStorm/LP (Continued)

Pin No.	Port No.	RS-232 Signal	Signal Direction	RS-422/485 Signal	Signal Direction
47	6	RTS	output	RTS-	output
48	6	DSR	input	CTS-	input
49	6	RXD	input	TXD+	output
50	6	CTS	input	RTS+	output
51	5, 6	SG	signal gnd.	SR	signal ref.
52	7, 8	SG	signal gnd.	SR	signal ref.
53	7	TXD	output	TXD-	output
54	7	RI	input	CTS+	input
55	7	DCD	input	RXD+	input
56	7	DTR	output	RXD-	input
57	7	RTS	output	RTS-	output
58	7	DSR	input	CTS-	input
59	7	RXD	input	TXD+	output
60	7	CTS	input	RTS+	output
61	8	TXD	output	TXD-	output
62	8	RI	input	CTS+	input
63	8	DCD	input	RXD+	input
64	8	DTR	output	RXD-	input
65	8	RTS	output	RTS-	output
66	8	DSR	input	CTS-	input
67	8	RXD	input	TXD+	output
68	8	CTS	input	RTS+	output

Cable CBG009 and/or IOBG08BLV1 will send the signals to eight DB-9 male connectors. See [Table 6](#) for the DB-9 pinouts. Cable CBG026 will send the signals to eight DB-25 male connectors. See [Table 6](#) for the DB-25 pinout details.

Table 4: HDB-78 Pinouts for BlueStorm/SP (8 Port Connector)

Pin No.	Port No.	RS-232 Signal	Signal Direction	RS-422/485 Signal	Signal Direction
1	5	RTS	output	RTS A(-)	output
2	5	CTS	input	RTS B(+)	output
3	5	DSR	input	CTS A(-)	input
4	5	RI	input	CTS B(+)	input
5	5	SG	signal gnd.	SR	signal ref.
6	6	RTS	output	RTS A(-)	output
7	6	CTS	input	RTS B(+)	output
8	6	DSR	input	CTS A(-)	input
9	6	RI	input	CTS B(+)	input
10	7	RTS	output	RTS A(-)	output
11	7	CTS	input	RTS B(+)	output
12	7	DSR	input	CTS A(-)	input
13	7	RI	input	CTS B(+)	input
14	7	SG	signal gnd.	SR	signal ref.
15	8	RTS	output	RTS A(-)	output
16	8	CTS	input	RTS B(+)	output
17	8	DSR	input	CTS A(-)	input
18	8	RI	input	CTS B(+)	input
19		NC	no connect	NC	no connect
20		NC	no connect	NC	no connect
21	5	TxD	output	TxD A(-)	output
22	5	RxD	input	TxD B(+)	output
23	5	DTR	output	RxD A(-)	input
24	5	DCD	input	RxD B(+)	input
25	6	SG	signal gnd.	SR	signal ref.
26	6	TxD	output	TxD A(-)	output
27	6	RxD	input	TxD B(+)	output
28	6	DTR	output	RxD A(-)	input
29	6	DCD	input	RxD B(+)	input
30	7	TxD	output	TxD A(-)	output
31	7	RxD	input	TxD B(+)	output
32	7	DTR	output	RxD A(-)	input
33	7	DCD	input	RxD B(+)	input
34		SG	signal gnd.	NC	no connect
35	8	TxD	output	TxD A(-)	output
36	8	RxD	input	TxD B(+)	output
37	8	DTR	output	RxD A(-)	input
38	8	DCD	input	RxD B(+)	input
39	8	SG	signal gnd.	SR	signal ref.

...Continued on next page

Table 4: HDB-78 Pinouts for BlueStorm/SP (Continued)

Pin No.	Port No.	RS-232 Signal	Signal Direction	RS-422/485 Signal	Signal Direction
40	1	RTS	output	RTS A(-)	output
41	1	CTS	input	RTS B(+)	output
42	1	DSR	input	CTS A(-)	input
43	1	RI	input	CTS B(+)	input
44	1	SG	signal gnd.	SR	signal ref.
45	2	RTS	output	RTS A(-)	output
46	2	CTS	input	RTS B(+)	output
47	2	DSR	input	CTS A(-)	input
48	2	RI	input	CTS B(+)	input
49	3	RTS	output	RTS A(-)	output
50	3	CTS	input	RTS B(+)	output
51	3	DSR	input	CTS A(-)	input
52	3	RI	input	CTS B(+)	input
53	3	SG	signal gnd.	SR	signal ref.
54	4	RTS	output	RTS A(-)	output
55	4	CTS	input	RTS B(+)	output
56	4	DSR	input	CTS A(-)	input
57	4	RI	input	CTS B(+)	input
58		NC	no connect	NC	no connect
59		NC	no connect	NC	no connect
60	1	TxD	output	TxD A(-)	output
61	1	RxD	input	TxD B(+)	output
62	1	DTR	output	RxD A(-)	input
63	1	DCD	input	RxD B(+)	input
64	2	SG	signal gnd.	SR	signal ref.
65	2	TxD	output	TxD A(-)	output
66	2	RxD	input	TxD B(+)	output
67	2	DTR	output	RxD A(-)	input
68	2	DCD	input	RxD B(+)	input
69	3	TxD	output	TxD A(-)	output
70	3	RxD	input	TxD B(+)	output
71	3	DTR	output	RxD A(-)	input
72	3	DCD	input	RxD B(+)	input
73	4	SG	signal gnd.	SR	signal ref.
74	4	TxD	output	TxD A(-)	output
75	4	RxD	input	TxD B(+)	output
76	4	DTR	output	RxD A(-)	input
77	4	DCD	input	RxD B(+)	input
78		NC	no connect	NC	no connect

Cable CAG08FXDX and/or the IOBG08DB9V1 will send the signals to eight DB-9 male connectors. See [Table 6](#) for the DB-9 pinouts. Cable CAG08DB25 will send the signals to eight DB-25 connectors. See [Table 6](#) for the DB-25 pinouts.

Table 5: RJ-45 Pinouts for BlueStorm/SP Opto (4 Port Connector)

Pin No.	RS-232 Signal	Direction	RS-422/485 Signal	Direction
1	N/C	no connect	RTS (-)	output
2	N/C	input	RxD (+)	input
3	RTS	output	RTS (+)	output
4	SG	signal gnd	SR	signal ref.
5	TxD	output	TxD (+)	output
6	RxD	input	RxD (-)	input
7	Gnd	ground	Gnd.	ground
8	CTS	input	CTS (+)	input
9	N/C	no connect	TxD (-)	output
10	N/C	no connect	CTS (-)	input
RJ-45 connector 				

Cable CAGRJ4509 will send the signals to eight DB-9 male connectors. See [Table 7](#) for the DB-9 pinouts

Table 6: Pinouts and Control Signals for DB-9 and DB-25 Male Connectors (BlueStorm/LP and BlueStorm/SP Only)

Pin #		RS-232		RS-422/485	
DB-9	DB-25	Signal	Signal Direction	Signal	Signal Direction
1	8	DCD	input	RxD +	input
2	3	RxD	input	TxD +	output
3	2	TxD	output	TxD -	output
4	20	DTR	output	RxD -	input
5	7	SG	signal gnd.	SR	signal ref.
6	6	DSR	input	CTS -	input
7	4	RTS	output	RTS -	output
8	5	CTS	input	RTS +	output
9	22	RI	input	CTS +	input

DB-9 male 	DB-25 male 
--	--

Table 7: Pinouts and Control Signals for DB-9 Male Connectors (BlueStorm/SP Opto Only)

Pin No.	RS-232 Signal	Direction	RS-422/485 Signal	Direction
1	N/C	no connect	RxD (+)	input
2	RxD	input	RxD (-)	input
3	TxD	output	TxD (+)	output
4	N/C	no connect	TxD (-)	output
5	SG	signal gnd	SR	signal ref.
6	N/C	no connect	CTS (-)	input
7	RTS	output	RTS (+)	output
8	CTS	input	CTS (+)	input
9	N/C	no connect	RTS (-)	output

Male DB-9 Connector 

Please note that the DB-9 pinouts for BlueStorm/LP and BlueStorm/SP differ from the BlueStorm/SP Opto

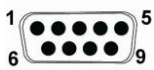
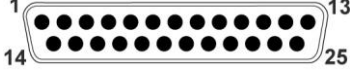
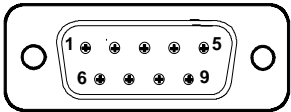
Table 8: RJ-11 Pinouts for BlueStorm/SP RJ-11 (Ports 7 and 8 Only)

Pin No.	RS-232	Direction
1	DCD	input
2	DSR	input
3	RxD	input
4	RTS	output
5	TxD	output
6	CTS	input
7	DTR	output
8	RI	input
9	SG	signal gnd.
10	N/C	no connect

Please note that ports 7 and 8 are not accessible through the factory installed bracket.

Table 9: Pinouts and Control Signals for RJ-11 Connectors (BlueStorm/SP RJ-11 Only)

Ports 7 and 8 when a DB-9 cable (part number CAG104K) is attached			Ports 1 through 6, which are accessible through the factory installed bracket		
DB-9 Pin No.	RS-232 Signal	Direction	RJ-11 Pin No.	RS-232 Signal	Direction
1	DCD	input	1	RTS	output
2	RxD	input	2	RxD	input
3	TxD	output	3	TxD	output
4	DTR	output	4	DSR	input
5	SG	signal ground	5	SG	Signal/power ground
6	DSR	input	6	+12 VDC** or +5 VDC**	output
7	RTS	output			
8	CTS	input			
9	RI	input	** J1 selects +5 VDC, J2 selects +12 VDC		

<p>Male DB-9 Connector</p>	<p>RJ-11 Connector</p>
----------------------------	------------------------

Part #: CAG104K

Technical Tip:
 Please ensure that you terminate the CTS signal if your application does not use them. The common way to do this is to connect CTS to RTS. Failure to do so may result in loss of a performance on your BlueStorm/SP RJ-11 adapter.

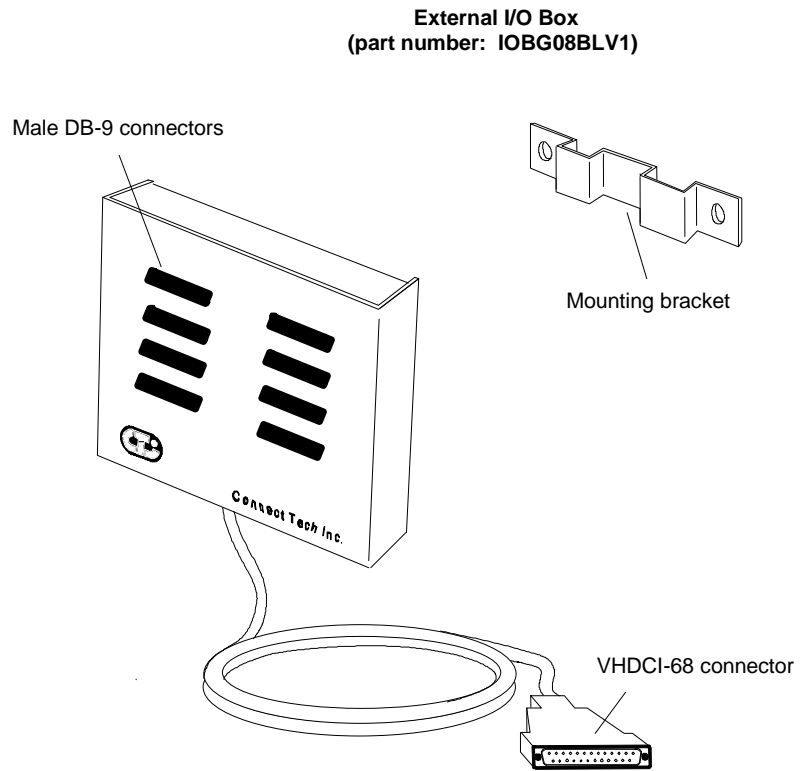

Figure 10: BlueStorm External I/O Box Diagram

Note: View VHDCI-68 connector pinouts in [Table 3](#). I/O box IOBG08BLV1 will send the signals to eight DB-9 male connectors. See [Table 6](#) for the DB-9 pinouts.

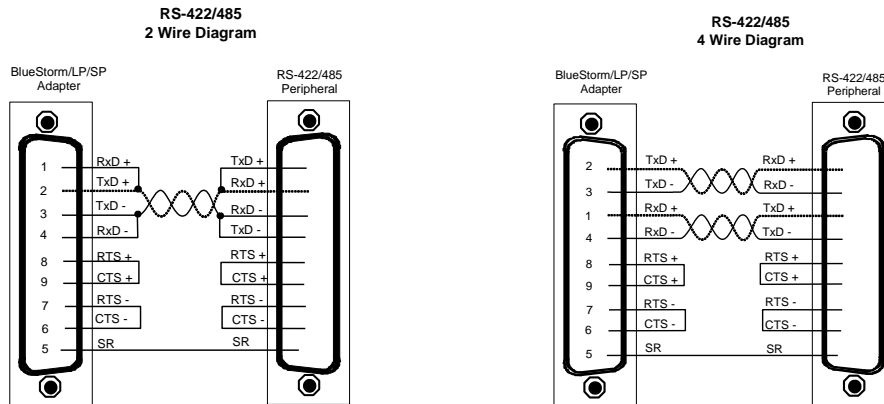

Figure 11: RS-422/485 Wiring Diagrams (BlueStorm/LP and BlueStorm/SP Only)

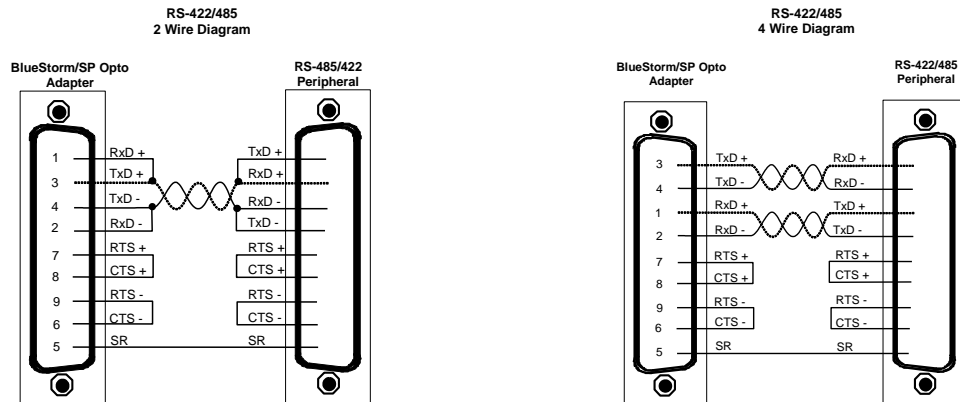

Figure 12: RS-422/485 Wiring Diagrams (BlueStorm/SP Opto Only)

Hardware Installation

Turn the power off to your computer and open it to expose the expansion slots (consult your system's documentation for more information about this procedure).

Choose an available PCI expansion slot, remove the expansion slot cover and insert the BlueStorm adapter, pushing down gently until the board seats fully in the slot. Secure the BlueStorm card to the computer chassis.

Software/Driver Installation

BlueStorm provides support for QNX 4.X/6.X, Windows 2000/CE/NT/XP/XPe/XP 64-Bit/Server 2003/Server 2003 64-Bit, Vista, VxWorks, Ardenne RTX and Linux. For installation guidelines and driver codes, please refer to the appropriate directories on the BlueStorm CD. For further information concerning software installation of BlueStorm products please visit Connect Tech's [Download Zone](#).

If you are interested in a device driver for an operating system not listed please contact the [Connect Tech Sales Department](#).

Specifications

Operating Environment

BlueStorm/LP

- Storage temperature: -55°C to 125°C
- Operating temperature: 0°C to 70°C
- Humidity: 5 to 95% non-condensing

BlueStorm/SP, BlueStorm/SP Opto and BlueStorm/SP RJ-11

- Storage temperature: -55°C to 105°C
- Operating temperature: 0°C to 70°C
- Humidity: 5 to 95% non-condensing

PCI Bus Interface

BlueStorm/LP

3.3V or 5V PCI bus.

Please note that the BlueStorm/LP can ship with low and standard profile brackets.

BlueStorm/SP, BlueStorm/SP Opto and BlueStorm/SP RJ-11

3.3V or 5V PCI bus

Communications

Baud Rates

RS-232: 50 bps – 921.6 Kbps

RS-422/485: 50 bps – 1.8432 Mbps

Custom baud rates are also available; please contact our [Sales Department](#) for information.

UARTs

BlueStorm/LP (2 port models)

- 17D152 dual UART with 64 byte TxD/RxD FIFO buffers

BlueStorm/LP (4 port models)

- 17D154 quad UART with 64 byte TxD/RxD FIFO buffers

BlueStorm/LP (8 port models)

- 17D158 octal UART with 64 byte TxD/RxD FIFO buffers

BlueStorm/SP and BlueStorm/SP RJ-11 (8 port models)

- 17D158 octal UART with 64 byte TxD/RxD FIFO buffers

BlueStorm/SP Opto (2 and 4 port models)

- 17D152 dual UART(s) with 64 byte TxD/RxD FIFO buffers

Surge Suppression

BlueStorm/LP/SP/SP RJ-11 (excludes BlueStorm/SP Opto)

- TransGuard[®] Transient Voltage Suppression, able to withstand multiple strikes on every signal of every port
- Transient Energy dissipation 0.05 joules on every signal of every port
- Transient peak current rating 15A on every signal of every port
- EN61000-4-2/3/4 compatible

Optical Isolation

BlueStorm/SP Opto

- 3kV peak to peak optical isolation on every signal of every port

Dimensions

BlueStorm/LP

Low profile form factor - MD1 compliant

BlueStorm/SP

Length: 11.991 cm, 4.721 inches

Height: 9.652 cm, 3.8 inches

BlueStorm/SP Opto

Length: 14.702 cm, 5.788 inches

Height: 10.605 cm, 4.175 inches

BlueStorm/SP RJ-11

Length: 12.129 cm, 4.775 inches

Height: 10.668 cm, 4.2 inches

Certification

Connect Tech Inc. declares that the product(s) covered by the contents of this manual have been tested and found compliant with the below listed standards as required by the Electromagnetic Compatibility (EMC) Directive for General Immunity Compliance, EN 50 0082.1:1997

EN 55022 Conducted and Radiated emissions
CISPR 22 Class A

EN 55024 Immunity to Disturbances

EN 61000-4-2		EN 61000-4-4
EN 61000-4-3		EN 61000-4-6

The above satisfy the requirements of:

USA: FCC Class A 47CFR, Part 2
Canada: ICES-003
Europe: EMC Directive
Japan: VCCI
Australia/New Zealand: AS/NZS



The above agency conformances were met by independent laboratory testing of Connect Tech Inc. product(s) with shielded cables, with metal hoods, attached to either the terminating connectors or cable assemblies supplied with the product(s). Failure to follow good EMC/EMI compliant cabling practices may produce more emissions or less immunity than were obtained in laboratory measurements.

Operation of this equipment in a residential area may cause unacceptable interference to radio and TV reception, requiring the user to take whatever steps necessary to correct the interference.

