

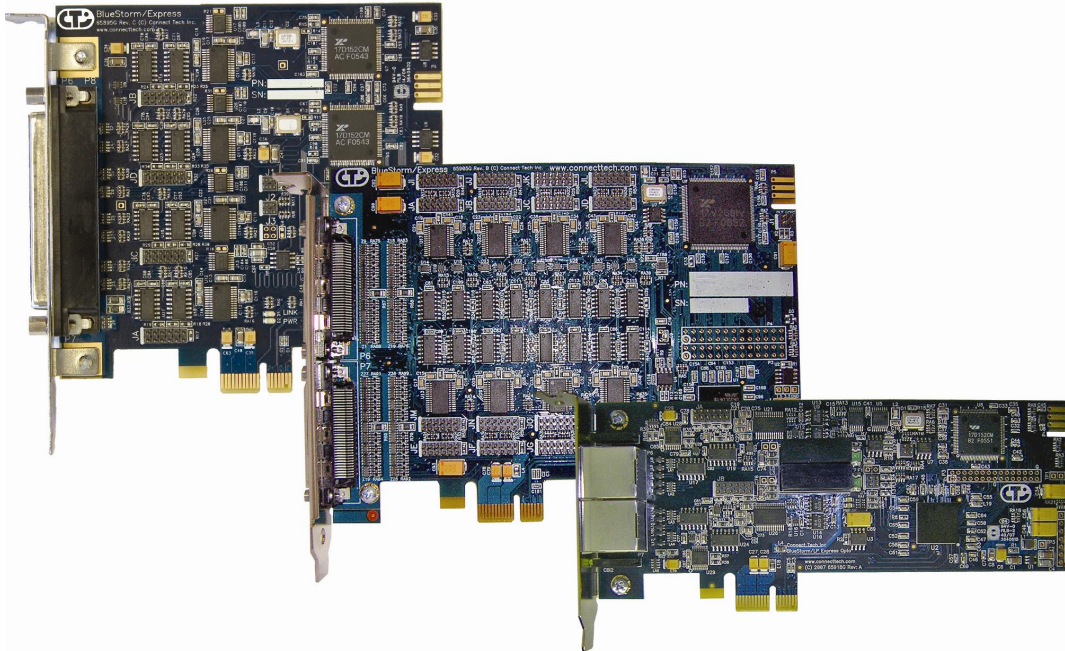

Connect Tech Inc.
Industrial Strength Communications

BlueStorm/Express

User Manual



Connect Tech Inc
42 Arrow Road
Guelph, Ontario
N1K 1S6

Tel: 519-836-1291
Toll: 800-426-8979 (North America only)
Fax: 519-836-4878
Email: sales@connecttech.com
support@connecttech.com
Web: www.connecttech.com

CTIM-00033 Revision 0.07 February 13, 2008

Limited Lifetime Warranty

Connect Tech Inc. provides a Lifetime Warranty for all Connect Tech Inc. products. Should this product, in Connect Tech Inc.'s opinion, fail to be in good working order during the warranty period, Connect Tech Inc. will, at its option, repair or replace this product at no charge, provided that the product has not been subjected to abuse, misuse, accident, disaster or non-Connect Tech Inc. authorized modification or repair.

You may obtain warranty service by delivering this product to an authorized Connect Tech Inc. business partner or to Connect Tech Inc. along with proof of purchase. Product returned to Connect Tech Inc. must be pre-authorized by Connect Tech Inc. with an RMA (Return Material Authorization) number marked on the outside of the package and sent prepaid, insured and packaged for safe shipment. Connect Tech Inc. will return this product by prepaid ground shipment service.

The Connect Tech Inc. Lifetime Warranty is defined as the serviceable life of the product. This is defined as the period during which all components are available. Should the product prove to be irreparable, Connect Tech Inc. reserves the right to substitute an equivalent product if available or to retract Lifetime Warranty if no replacement is available.

The above warranty is the only warranty authorized by Connect Tech Inc. Under no circumstances will Connect Tech Inc. be liable in any way for any damages, including any lost profits, lost savings or other incidental or consequential damages arising out of the use of, or inability to use, such product.

Copyright Notice

The information contained in this document is subject to change without notice. Connect Tech Inc. shall not be liable for errors contained herein or for incidental consequential damages in connection with the furnishing, performance, or use of this material. This document contains proprietary information that is protected by copyright. All rights are reserved. No part of this document may be photocopied, reproduced, or translated to another language without the prior written consent of Connect Tech, Inc.

Copyright © 1997 - 2008 by Connect Tech, Inc.

Trademark Acknowledgment

Connect Tech, Inc. acknowledges all trademarks, registered trademarks and/or copyrights referred to in this document as the property of their respective owners.

Not listing all possible trademarks or copyright acknowledgments does not constitute a lack of acknowledgment to the rightful owners of the trademarks and copyrights mentioned in this document.

Table of Contents

Limited Lifetime Warranty.....	2
Copyright Notice	2
Trademark Acknowledgment	2
Table of Contents	3
Customer Support Overview	5
Contact Information.....	5
Introduction	6
Features	6
BlueStorm/Express Diagrams.....	7
BlueStorm/Express Installation Overview	11
Hardware Configuration	12
Interrupts and Memory Address Selection	12
Electrical Interfaces	12
RS-232 Electrical Interface	12
RS-422/485 Electrical Interface	12
<i>Full Duplex Mode</i>	12
<i>Half Duplex Mode</i>	12
<i>Multi-drop Mode</i>	12
<i>Line Bias/Termination</i>	12
Jumper Block Settings.....	12
Tri-state Operation.....	13
Connectors/Pinouts.....	15
<i>Hardware Installation</i>	22
Installing the BlueStorm/Express into your system.....	22
<i>Software Installation</i>	23
Software First Installation	23
Hardware First Installation	24
Windows XP Installation.....	24
Port Settings	25
Advanced Port Settings	26
<i>Use FIFO Buffers</i>	26
<i>Receive and Transmit FIFO Settings</i>	26
Software Settings for RS-422/485	26
<i>Baud Rate Mapping</i>	27
<i>Clock Frequency</i>	27
<i>COM Number</i>	27
Specifications	28
Operating Environment	28
PCI Express Interface	28
Communications.....	28
<i>Baud Rates</i>	28
<i>UARTs</i>	28
Surge Suppression	28
Optical Isolation	29
Dimensions.....	29
Certification.....	30

List of Figures

Figure 1: BlueStorm/Express RS-232/422/485 two and four port model hardware components..... 7
Figure 2: BlueStorm/Express RS-232/422/485 eight & 16 port models hardware components 8
Figure 3: BlueStorm/Express Opto RS-232/422/485 four port model hardware components 9
Figure 4: BlueStorm/Express Opto (1 kV) RS-232/422/485 eight port model hardware components 10
Figure 5: BlueStorm/Express LP Opto RS232/422/485 two port model hardware components..... 10
Figure 6: BlueStorm/Express LP RS-232/422/485 eight port hardware components..... 11
Figure 7: Example of various port configuration jumper block settings..... 13
Figure 8: BlueStorm/Express I/O box diagram..... 21
Figure 9: RS-422/485 wiring diagram (BlueStorm/Express only) 22
Figure 10: RS-422/485 wiring diagram (BlueStorm/Express Opto only) 22

List of Tables

Table 1: DB-37 female pinouts..... 15
Table 2: DB-9 male pinouts 16
Table 3: VHDCI-68 female pinouts..... 16
Table 4: RJ-45 pinouts for BlueStorm/Express Opto and BlueStorm/Express LP Opto 18
Table 5: DB-9 male pinouts for BlueStorm/Express Opto and BlueStorm/Express LP Opto..... 18
Table 6: DB-78 female pinouts for BlueStorm/Express Opto (8 port 1 kV model)..... 19
Table 7: DB-25 male pinouts..... 21

Customer Support Overview

If you experience difficulties after reading the manual and/or using the product, contact the Connect Tech reseller from which you purchased the product. In most cases the reseller can help you with product installation and difficulties.

In the event that the reseller is unable to resolve your problem, our highly qualified support staff can assist you. Our support section is available 24 hours a day, 7 days a week on our website at: www.connecttech.com/sub/support/support.asp. See the contact information section below for more information on how to contact us directly. Our technical support is always free.

Contact Information

We offer three ways for you to contact us:

Mail/Courier

You may contact us by letter at:

Connect Tech Inc.
Technical Support
42 Arrow Road
Guelph, Ontario
Canada N1K 1S6

Email/Internet

You may contact us through the Internet. Our email and URL addresses on the Internet are:

sales@connecttech.com
support@connecttech.com
www.connecttech.com

Note:

Please go to the [Download Zone](#) or the [Knowledge Database](#) in the [Support Center](#) on the Connect Tech website for product manuals, installation guides, device driver software and technical tips.

Submit your technical support questions to our customer support engineers via the [Support Center](#) on the Connect Tech website.

Telephone/Facsimile

Technical Support representatives are ready to answer your call Monday through Friday, from 8:30 a.m. to 5:00 p.m. Eastern Standard Time. Our numbers for calls are:

Telephone: 800-426-8979 (North America only)
Telephone: 519-836-1291 (Live assistance available 8:30 a.m. to 5:00 p.m. EST, Monday to Friday)
Facsimile: 519-836-4878 (on-line 24 hours)

Introduction

Connect Tech's BlueStorm/Express family offers compatibility with the next generation in computer bus standards. Available in two, four, eight and sixteen ports, these x1 lane PCI Express serial cards make it easy to add a wide variety of serial communications options to computers with a PCI Express bus. Your existing serial peripherals can connect directly to the BlueStorm/Express serial card, using legacy application software from your PCI system.

Instead of relying on shared parallel bus architecture, PCI Express is built around bidirectional, dedicated point-to-point "lanes." This technology allows extensive future scalability. With the future in mind, Connect Tech designed the BlueStorm/Express to ensure compatibility with future versions of the PCI Express bus.

The BlueStorm/Express is perfect for a variety of applications such as retail/point of sale, automated teller machines, transportation stations, lottery terminals and self-service kiosks, among others.

Features

- 2, 4, 8, or 16 hardware switchable RS-232/422/485 ports
- x1 lane PCI Express, compatible with any PCI Express slot width
- Standard and low profile models available
- Supports full duplex (four wire) with RTS/CTS flow control, half duplex (two wire) with auto TxD echo cancellation and multi-drop (four wire) communication modes in RS-422/485
- Bidirectional data communication speeds to 1.8432 Mbps in RS-422/485 and 921.6 Kbps in RS-232
- Hardware selectable for tri-state on power-up in RS-485 modes (applies to two and four port BlueStorm/Express, BlueStorm/Express LP eight port cards and the BlueStorm/Express Opto)
- Surge suppression on every signal of every port
- Operating temperature range of 0°C to 70°C
- Software support for QNX 4.X/6.X, Linux, Windows 2000/CE/XP/XP x64/XPe/Server 2003/Server 2003 x64 and Vista
- Plug and play - no jumpers to set for memory or interrupt configuration
- Optical isolation available on select models:
 - Standard profile models feature 3 kV peak to peak on all signals, all ports**
 - Low profile model features 3 kV peak to peak optical isolation on every signal of every port

**Eight port model featuring four ports with 1 kV optical isolation and four non-isolated ports also available

BlueStorm/Express Diagrams

Figure 1: BlueStorm/Express RS-232/422/485 two and four port model hardware components

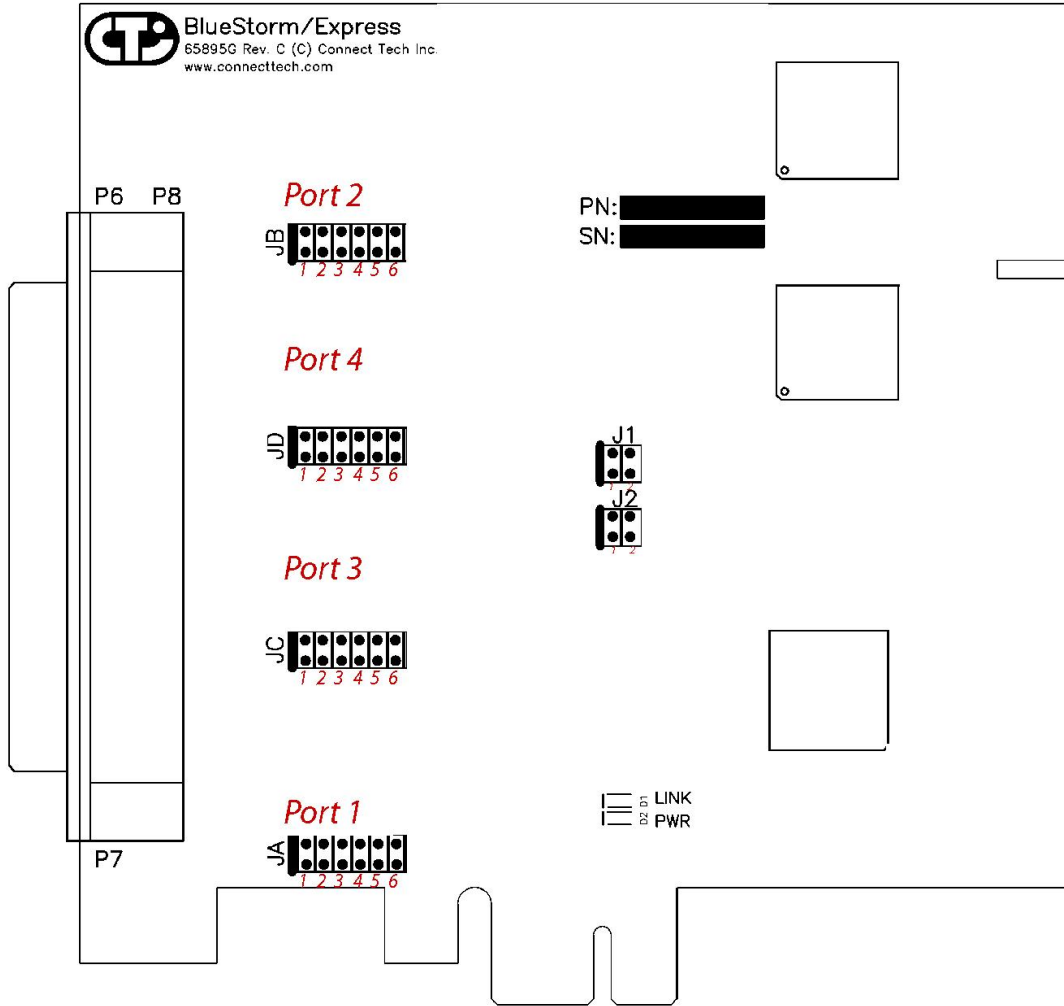

Note: The above example is a four port BlueStorm/Express model. JC and JD headers will not be installed on two port models.

Figure 2: BlueStorm/Express RS-232/422/485 eight & 16 port models hardware components



Note: The above example is a 16 port BlueStorm/Express model. Headers JI through JP will not be installed on eight port models

Figure 3: BlueStorm/Express Opto RS-232/422/485 four port model hardware components

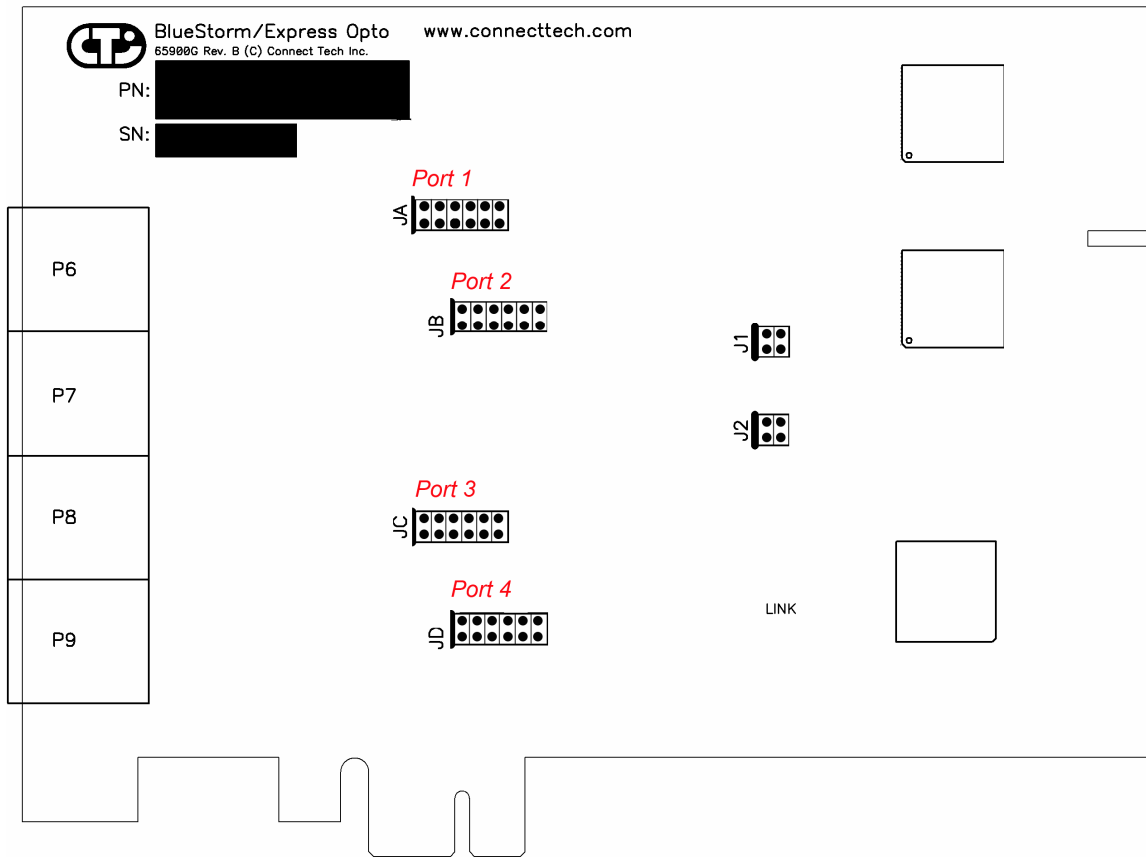

Note: The above example is a four port BlueStorm/Express Opto model installed with headers JA through JD.

Figure 4: BlueStorm/Express Opto (1 kV) RS-232/422/485 eight port model hardware components

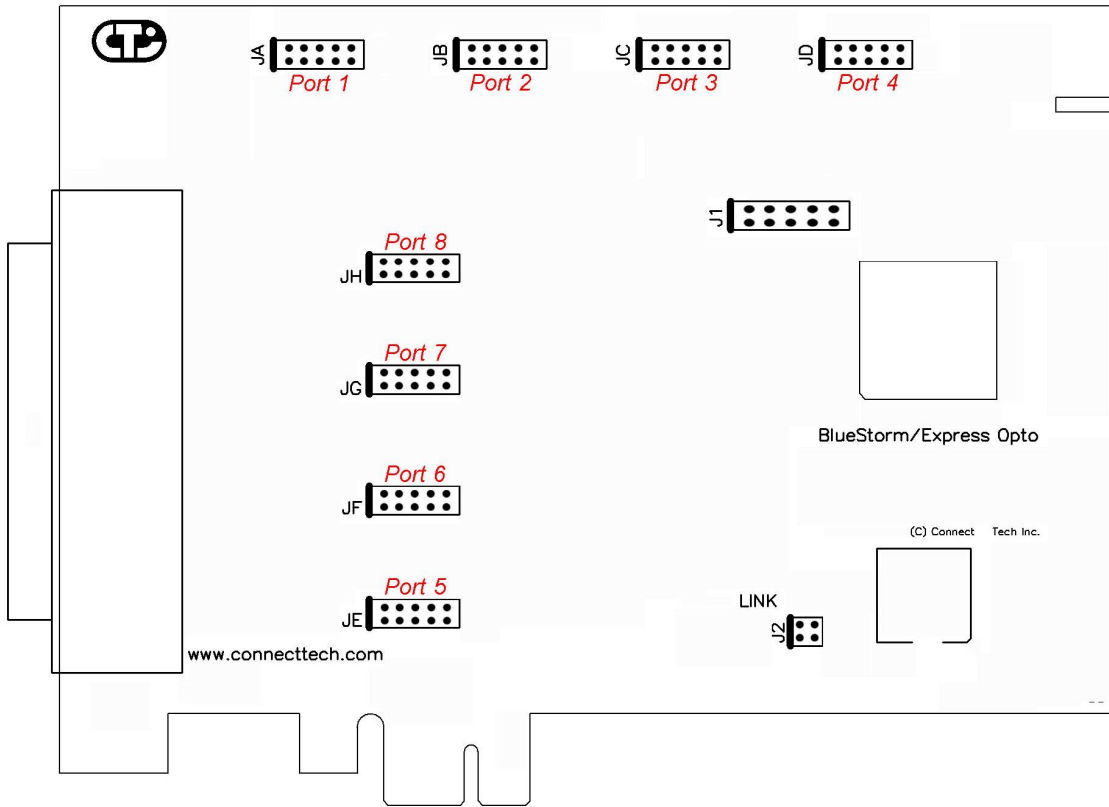

Note: The above example is an eight port model where ports 5 through 8 feature 1 kV optical isolation and ports 1 through 4 are non-isolated.

Figure 5: BlueStorm/Express LP Opto RS232/422/485 two port model hardware components

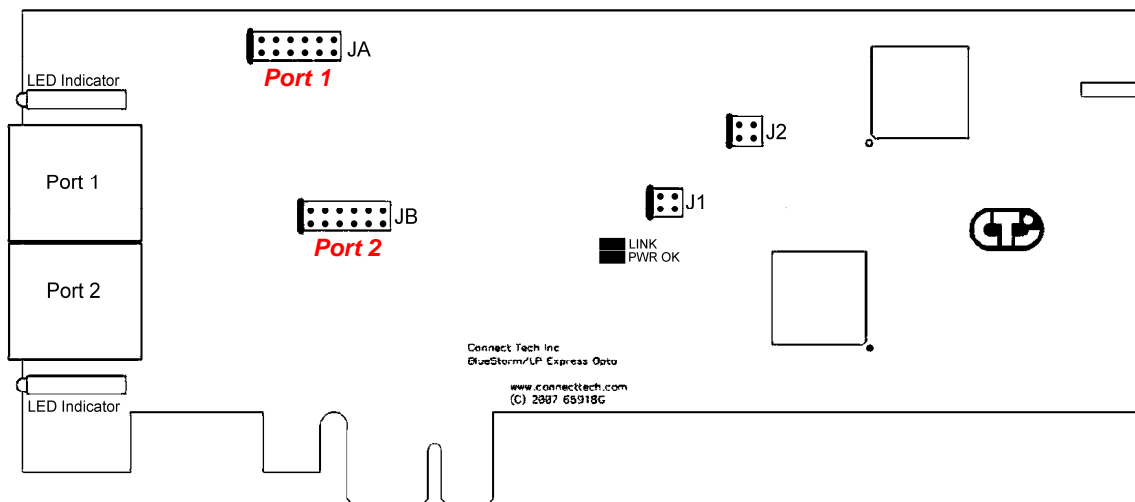
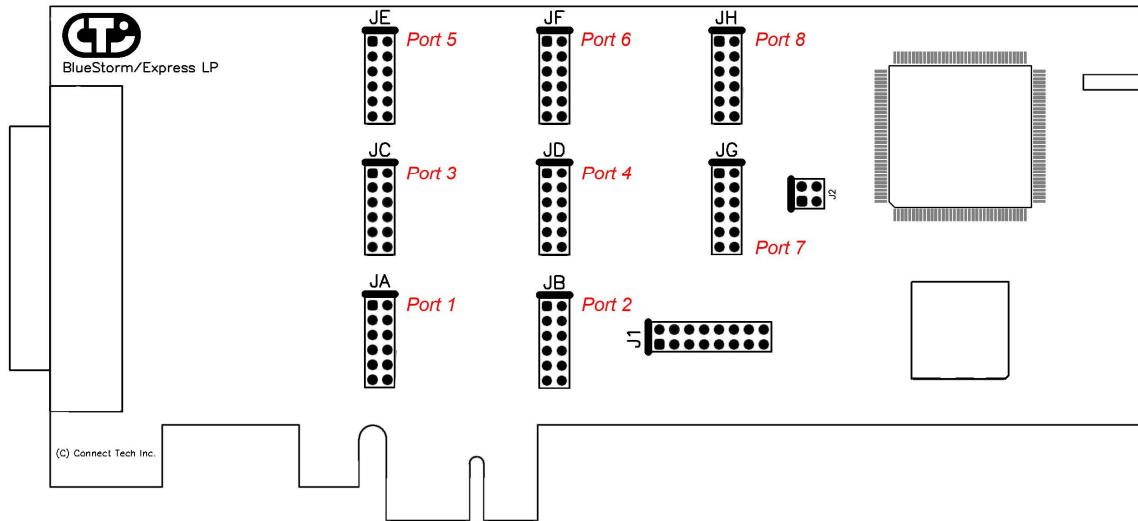

Figure 6: BlueStorm/Express LP RS-232/422/485 eight port hardware components



BlueStorm/Express Installation Overview

Before you begin, take a moment to ensure your package includes the components that ship with your product. These components should include:

- One BlueStorm/Express adapter
- One CD containing software and documentation
- DB-9 male fan-out cable(s) or DB-25 male fan-out cable(s) or an I/O box (optional).

If any of these components are missing, contact [Connect Tech](#) (see more [Contact Details](#)) or your reseller.

There are three stages to installing your BlueStorm/Express:

1. [Hardware Configuration](#)
Interrupts and Memory selection will be set by the host computer's BIOS and operating system. This section outlines jumper settings and configuration.
2. [Hardware Installation](#)
Installation involves the physical installation of the BlueStorm/Express into your computer. Please note that you should configure any jumper settings prior to installing the board. (If you choose to use the Windows Software First installation option, go to Section 3 before Section 2.)
3. [Software/driver installation](#)
Load the appropriate driver for your Operating System, as found on the accompanying CD. Installation guides are also available on the CD to aid you in this process. Please note that Windows users have two options for software installation:
 - Software First installations require that you install your drivers prior to installing the hardware into your system.

- Hardware First installations require the installation of the drivers when prompted by the operating system's hardware detection process after the hardware installation.

Hardware Configuration

Interrupts and Memory Address Selection

The BlueStorm/Express board is a PCI Express card, so the host computer's BIOS will automatically set interrupts and memory addresses when you power up the system.

Electrical Interfaces

RS-232 Electrical Interface

This is the default setting for the selectable interface of the BlueStorm/Express. To operate a port in RS-232 mode, no jumpers are set on the corresponding jumper block.

RS-422/485 Electrical Interface

The BlueStorm/Express models with support for RS-422/485 interface offer three modes of RS-422/485 communication, as outlined below.

(See [Figure 7](#) to see examples of jumper settings.)

Full Duplex Mode

In this mode, TxD+/- is being driven to a known level all the time. This mode is typically used in point-to-point situations much like RS-232. It is the default setting for RS-422/485 mode.

Half Duplex Mode

In this mode the TxD+/- line driver is enabled only when data is transmitted and RxD+/- is disabled when data is being transmitted. This mode is typically used in either point-to-point 2-wire connections OR in multi-drop 2-wire bus connections. This mode requires software setup in **Control Panel – System – Hardware – Device Manager – Ports – CTI PCI Express UART**. Click on **Advanced** under **Port Settings** after the driver is installed. (See [Port Settings](#)).

Multi-drop Mode

In this mode the TxD+/- line driver is enabled only when data is transmitted and RxD+/- is enabled all the time. This mode is typically used in multi-drop 4-wire connections. This mode requires software setup in **Control Panel – System Properties – Hardware – Device Manager – Ports – CTI PCI Express UART**. Click on **Advanced** under **Port Settings**. (See Half Duplex Mode above.)

Line Bias/Termination

The RS-422/485 transceivers, transmit and receive, are optionally biased to produce a line level mark condition through jumper selectable resistors. These options are typically used in multi-drop 4-wire connections.

Jumper Block Settings

The following jumper block diagram depicts typical settings on a four-port selectable BlueStorm/Express. Jumper blocks JA and JB control ports 1 and 2, JC and JD control ports 3 and 4, respectively. (See [Figure 1](#) for location of jumper blocks.)

Figure 7: Example of various port configuration jumper block settings

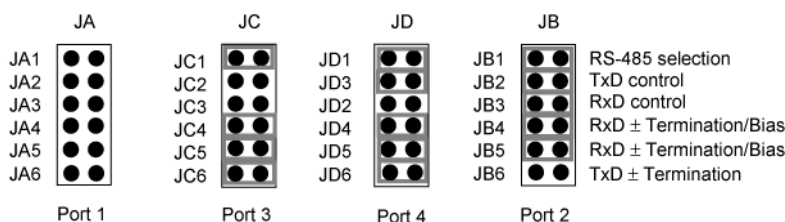

In this example, Port 1 (JA) is set to RS-232, Port 2 (JB) is set to RS-422/485 half duplex, Port 3 (JC) is set to RS-422/485 full duplex, and Port 4 (JD) is set to RS-422/485 multi-drop.

RS-485 Selection: Install this jumper to configure a port for RS-422/485 mode. If the jumper is not installed, the port will function in RS-232 mode. (All jumpers should be removed from any port operating in RS-232 mode.)

TxD Control: Install this jumper to enable the RS-485 transmitter only when sending data. This mode is useful for half-duplex operation when only one device is allowed to send data at a time. If the jumper is not installed, the transmitter will always drive the line to an idle state when not sending data.

RxD control: Install this jumper to enable the RS-485 receiver only when NOT transmitting data. This is useful for half-duplex operation to prevent the transmitting device from receiving the data it has sent. If this jumper is not installed, the receiver is always enabled and ready to receive data.

RxD ± Termination/Bias: Install this pair of jumpers to enable a 150 Ohm terminator across the RxD+ and RxD- pins for the corresponding port. A biasing network is also enabled that drives the receiver to an inactive or safe mode. The receiver can still receive data from another device and the biasing helps to prevent the reception of data generated by noise on the transmission line. The two jumpers for RxD termination/bias must be installed and removed as a pair.

TxD ± Termination: Install this jumper to enable a 150 Ohm resistor across the TxD+ and TxD- pins of the corresponding port.

[Half Duplex](#) and [Multi-drop](#) modes require you to select the appropriate mode via software. Please refer to the [readme.txt](#) files found in the appropriate directories on the CD.

Tri-state Operation

Jumper block J2 (see [Figure 1](#) for an example) controls Tx tri-state on boot for ports configured in RS-485 half duplex or multi-drop modes. This jumper block will have no effect on ports configured as RS-232 or RS-485 full duplex.

For BlueStorm/Express 2/4 port cards, jumper position 1 disables tri-state on boot for ports 1 and 2. Jumpering position 2 disables tri-state on boot for ports 3 and 4.

For BlueStorm/Express Opto and BlueStorm/Express LP Opto cards, jumpering position 1 enables tri-state on boot for ports 1 and 2. Jumpering position 2 enables tri-state on boot for ports 3 and 4.

Jumper block J1 is used in diagnostic modes and should be left unpopulated unless directed otherwise by Connect Tech's technical support in the diagnosing of a system problem.

Power-On Tri-state (BlueStorm/Express LP eight port and BlueStorm/Express Opto 1 kV model only)

BlueStorm/Express LP eight port and BlueStorm/Express Opto 1 kV models offer a power-on tri-state similar to the Auto-485 mode selection listed above. These BlueStorm/Express models will tri-state ports configured as RS-485 half duplex or multi-drop slave.

Jumper J1 controls the power-on tri-state functionality. Install a jumper on the first location of the J1 in order to tri-state Port 1 at power-on. Install a jumper on the second position for Port 2, etc. The ports will not come out of tri-state until the driver begins transmitting on the associated port. Installing a jumper on J1 will have no effect on ports configured in RS-232 mode.

[Half Duplex](#) and [Multi-drop Slave](#) modes require you to select the appropriate mode via software. Please refer to the `readme.txt` files found in the appropriate directories on the BlueStorm/Express CD.

Connectors/Pinouts

Table 1: DB-37 female pinouts

Pin No.	Port No.	RS-232 Signal	Direction	RS-422/485 Signal	Direction
1	1	SG	signal gnd	SR	signal ref
2	1	DTR	output	RxD A(-)	input
3	1	TxD	output	TxD A(-)	output
4	1	RxD	input	TxD B(+)	output
5	1	DCD	input	RxD B(+)	input
6		unused		unused	
7	3	RI	input	CTS B(+)	input
8	3	CTS	input	RTS B(+)	output
9	3	RTS	output	RTS A(-)	output
10	3	DSR	input	CTS A(-)	input
11	4	RI	input	CTS B(+)	input
12	4	CTS	input	RTS B(+)	output
13	4	RTS	output	RTS A(-)	output
14	4	DSR	input	CTS A(-)	input
15	2	SG	signal gnd	SR	signal ref
16	2	DTR	output	RxD A(-)	input
17	2	TxD	output	TxD A(-)	output
18	2	RxD	input	TxD B(+)	output
19	2	DCD	input	RxD B(+)	input
20	1	RI	input	CTS B(+)	input
21	1	CTS	input	RTS B(+)	output
22	1	RTS	output	RTS A(-)	output
23	1	DSR	input	CTS A(-)	input
24	3	SG	signal gnd	SR	signal ref
25	3	DTR	output	RxD A(-)	input
26	3	TxD	output	TxD A(-)	output
27	3	RxD	input	TxD B(+)	output
28	3	DCD	input	RxD B(+)	input
29	4	SG	signal gnd	SR	signal ref
30	4	DTR	output	RxD A(-)	input
31	4	TxD	output	TxD A(-)	output
32	4	RxD	input	TxD B(+)	output
33	4	DCD	input	RxD B(+)	input
34	2	RI	input	CTS B(+)	input
35	2	CTS	input	RTS B(+)	output
36	2	RTS	output	RTS A(-)	output
37	2	DSR	input	CTS A(-)	input

Cable CAG04DX will send the signals to four DB-9 male connectors. See [Table 2](#) for the DB-9 pinouts. Cable CAG04DB25 will send the signals to four DB-25 male connectors. See [Table 7](#) for the DB-25 pinouts.

Table 2: DB-9 male pinouts

Pin No.	RS-232 Signal	Direction	RS-422/485 Signal	Direction
1	DCD	input	RxD B(+)	input
2	RxD	input	TxD B(+)	output
3	TxD	output	TxD A(-)	output
4	DTR	output	RxD A(-)	input
5	SG	signal gnd	SR	signal ref.
6	DSR	input	CTS A(-)	input
7	RTS	output	RTS A(-)	output
8	CTS	input	RTS B(+)	output
9	RI	input	CTS B(+)	input

Male DB-9 Connector

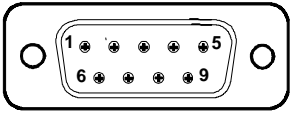

Table 3: VHDCI-68 female pinouts

Pin No.	Port No.	RS-232 Signal	Signal Direction	RS-422/485 Signal	Signal Direction
1	1	TXD	output	TXD-	output
2	1	RI	input	CTS+	input
3	1	DCD	input	RXD+	input
4	1	DTR	output	RXD-	input
5	1	RTS	output	RTS-	output
6	1	DSR	input	CTS-	input
7	1	RXD	input	TXD+	output
8	1	CTS	input	RTS+	output
9	2	TXD	output	TXD-	output
10	2	RI	input	CTS+	input
11	2	DCD	input	RXD+	input
12	2	DTR	output	RXD-	input
13	2	RTS	output	RTS-	output
14	2	DSR	input	CTS-	input
15	2	RXD	input	TXD+	output
16	2	CTS	input	RTS+	output
17	1, 2	SG	signal gnd.	SR	signal ref.
18	3, 4	SG	signal gnd.	SR	signal ref.
19	3	TXD	output	TXD-	output
20	3	RI	input	CTS+	input
21	3	DCD	input	RXD+	input
22	3	DTR	output	RXD-	input
23	3	RTS	output	RTS-	output
24	3	DSR	input	CTS-	input
25	3	RXD	input	TXD+	output
26	3	CTS	input	RTS+	output
27	4	TXD	output	TXD-	output
28	4	RI	input	CTS+	input
29	4	DCD	input	RXD+	input

Table 3: VHDCI-68 female pinouts (continued)

Pin No.	Port No.	RS-232 Signal	Signal Direction	RS-422/485 Signal	Signal Direction
30	4	DTR	output	RXD-	input
31	4	RTS	output	RTS-	output
32	4	DSR	input	CTS-	input
33	4	RXD	input	TXD+	output
34	4	CTS	input	RTS+	output
35	5	TXD	output	TXD-	output
36	5	RI	input	CTS+	input
37	5	DCD	input	RXD+	input
38	5	DTR	output	RXD-	input
39	5	RTS	output	RTS-	output
40	5	DSR	input	CTS-	input
41	5	RXD	input	TXD+	output
42	5	CTS	input	RTS+	output
43	6	TXD	output	TXD-	output
44	6	RI	input	CTS+	input
45	6	DCD	input	RXD+	input
46	6	DTR	output	RXD-	input
47	6	RTS	output	RTS-	output
48	6	DSR	input	CTS-	input
49	6	RXD	input	TXD+	output
50	6	CTS	input	RTS+	output
51	5, 6	SG	signal gnd.	SR	signal ref.
52	7, 8	SG	signal gnd.	SR	signal ref.
53	7	TXD	output	TXD-	output
54	7	RI	input	CTS+	input
55	7	DCD	input	RXD+	input
56	7	DTR	output	RXD-	input
57	7	RTS	output	RTS-	output
58	7	DSR	input	CTS-	input
59	7	RXD	input	TXD+	output
60	7	CTS	input	RTS+	output
61	8	TXD	output	TXD-	output
62	8	RI	input	CTS+	input
63	8	DCD	input	RXD+	input
64	8	DTR	output	RXD-	input
65	8	RTS	output	RTS-	output
66	8	DSR	input	CTS-	input
67	8	RXD	input	TXD+	output
68	8	CTS	input	RTS+	output

Cable CBG009 or I/O box IOBG08BLV1 will send the signals to eight DB-9 male connectors. See [Table 2](#) for the DB-9 pinouts. Cable CBG026 will send the signals to eight DB-25 male connectors. See [Table 7](#) for the DB-25 pinouts.

Table 4: RJ-45 pinouts for BlueStorm/Express Opto and BlueStorm/Express LP Opto

Pin No.	RS-232 Signal	Direction	RS-422/485 Signal	Direction
1	N/C	no connect	RTS (-)	output
2	N/C	input	RxD (+)	input
3	RTS	output	RTS (+)	output
4	SG	signal gnd	SR	signal ref.
5	TxD	output	TxD (+)	output
6	RxD	input	RxD (-)	input
7	Gnd	ground	Gnd.	ground
8	CTS	input	CTS (+)	input
9	N/C	no connect	TxD (-)	output
10	N/C	no connect	CTS (-)	input

RJ-45 connector



Cable CAGRJ4509 will send the signals to four DB-9 male connectors. See [Table 5](#) for the DB-9 pinouts provided by this cable.

Table 5: DB-9 male pinouts for BlueStorm/Express Opto and BlueStorm/Express LP Opto

Pin No.	RS-232 Signal	Direction	RS-422/485 Signal	Direction
1	N/C	no connect	RxD (+)	input
2	RxD	input	RxD (-)	input
3	TxD	output	TxD (+)	output
4	N/C	no connect	TxD (-)	output
5	SG	signal gnd	SR	signal ref.
6	N/C	no connect	CTS (-)	input
7	RTS	output	RTS (+)	output
8	CTS	input	CTS (+)	input
9	N/C	no connect	RTS (-)	output

Male DB-9 Connector

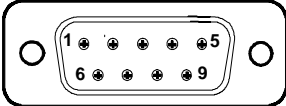

Table 6: DB-78 female pinouts for BlueStorm/Express Opto (8 port 1 kV model)

Pin No.	Port No.	RS-232 Signal	Signal Direction	RS-422/485 Signal	Signal Direction
1	5	RTS	output	RTS A(-)	output
2	5	CTS	input	RTS B(+)	output
3	5	NC	no connect	CTS A(-)	input
4	5	NC	no connect	CTS B(+)	input
5	5	SG	signal gnd.	SR	signal ref.
6	6	RTS	output	RTS A(-)	output
7	6	CTS	input	RTS B(+)	output
8	6	NC	no connect	CTS A(-)	input
9	6	NC	no connect	CTS B(+)	input
10	7	RTS	output	RTS A(-)	output
11	7	CTS	input	RTS B(+)	output
12	7	NC	no connect	CTS A(-)	input
13	7	NC	no connect	CTS B(+)	input
14	7	SG	signal gnd.	SR	signal ref.
15	8	RTS	output	RTS A(-)	output
16	8	CTS	input	RTS B(+)	output
17	8	NC	no connect	CTS A(-)	input
18	8	NC	no connect	CTS B(+)	input
19		NC	no connect	NC	no connect
20		NC	no connect	NC	no connect
21	5	TxD	output	TxD A(-)	output
22	5	RxD	input	TxD B(+)	output
23	5	NC	no connect	RxD A(-)	input
24	5	NC	no connect	RxD B(+)	input
25	6	SG	signal gnd.	SR	signal ref.
26	6	TxD	output	TxD A(-)	output
27	6	RxD	input	TxD B(+)	output
28	6	NC	no connect	RxD A(-)	input
29	6	NC	no connect	RxD B(+)	input
30	7	TxD	output	TxD A(-)	output
31	7	RxD	input	TxD B(+)	output
32	7	NC	no connect	RxD A(-)	input
33	7	NC	no connect	RxD B(+)	input
34		NC	no connect	NC	no connect
35	8	TxD	output	TxD A(-)	output
36	8	RxD	input	TxD B(+)	output
37	8	NC	no connect	RxD A(-)	input
38	8	NC	no connect	RxD B(+)	input
39	8	SG	signal gnd.	SR	signal ref.
40	1	RTS	output	RTS A(-)	output
41	1	CTS	input	RTS B(+)	output
42	1	DSR	input	CTS A(-)	input
43	1	RI	input	CTS B(+)	input
44	1	SG	signal gnd.	SR	signal ref.
45	2	RTS	output	RTS A(-)	output
46	2	CTS	input	RTS B(+)	output

Table 6: DB-78 female pinouts for BlueStorm/Express Opto (8 port 1 kV model) continued

Pin No.	Port No.	RS-232 Signal	Signal Direction	RS-422/485 Signal	Signal Direction
47	2	DSR	input	CTS A(-)	input
48	2	RI	input	CTS B(+)	input
49	3	RTS	output	RTS A(-)	output
50	3	CTS	input	RTS B(+)	output
51	3	DSR	input	CTS A(-)	input
52	3	RI	input	CTS B(+)	input
53	3	SG	signal gnd.	SR	signal ref.
54	4	RTS	output	RTS A(-)	output
55	4	CTS	input	RTS B(+)	output
56	4	DSR	input	CTS A(-)	input
57	4	RI	input	CTS B(+)	input
58		NC	no connect	NC	no connect
59		NC	no connect	NC	no connect
60	1	TxD	output	TxD A(-)	output
61	1	RxD	input	TxD B(+)	output
62	1	DTR	output	RxD A(-)	input
63	1	DCD	input	RxD B(+)	input
64	2	SG	signal gnd.	SR	signal ref.
65	2	TxD	output	TxD A(-)	output
66	2	RxD	input	TxD B(+)	output
67	2	DTR	output	RxD A(-)	input
68	2	DCD	input	RxD B(+)	input
69	3	TxD	output	TxD A(-)	output
70	3	RxD	input	TxD B(+)	output
71	3	DTR	output	RxD A(-)	input
72	3	DCD	input	RxD B(+)	input
73	4	SG	signal gnd.	SR	signal ref.
74	4	TxD	output	TxD A(-)	output
75	4	RxD	input	TxD B(+)	output
76	4	DTR	output	RxD A(-)	input
77	4	DCD	input	RxD B(+)	input
78		NC	no connect	NC	no connect

Cable CAG08FXDX will send the signals to eight DB-9 male connectors. See [Table 2](#) for the DB-9 pinouts

Table 7: DB-25 male pinouts

Pin #		RS-232		RS-422/485	
DB-9	DB-25	Signal	Signal Direction	Signal	Signal Direction
1	8	DCD	input	RxD +	input
2	3	RxD	input	TxD +	output
3	2	TxD	output	TxD -	output
4	20	DTR	output	RxD -	input
5	7	SG	signal gnd.	SR	signal ref.
6	6	DSR	input	CTS -	input
7	4	RTS	output	RTS -	output
8	5	CTS	input	RTS +	output
9	22	RI	input	CTS +	input

DB-9 male

DB-25 male

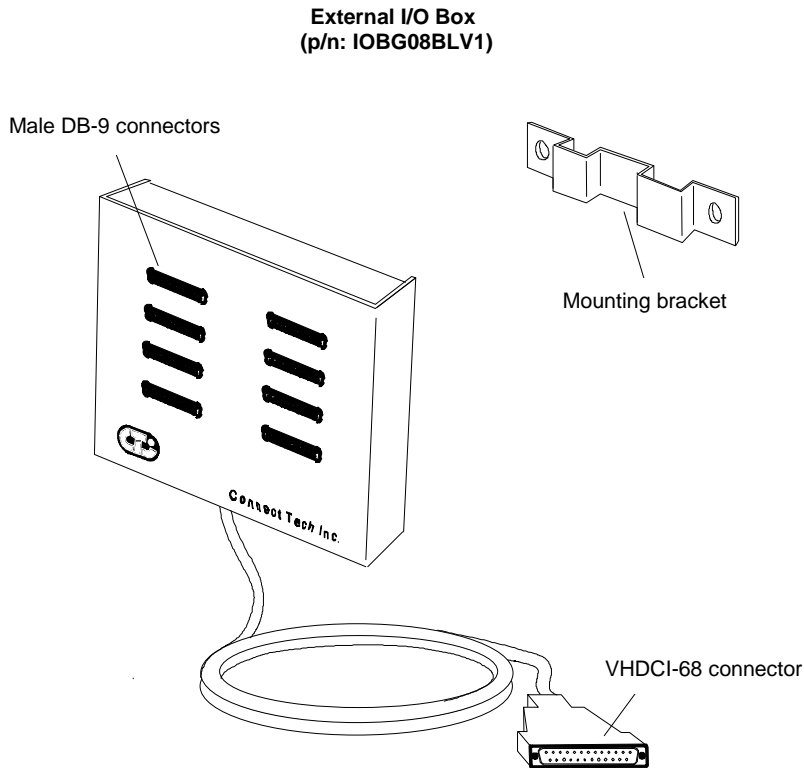

Figure 8: BlueStorm/Express I/O box diagram

Note: View VHDCI-68 connector pinouts in [Table 3](#). I/O box IOBG08BLV1 will send the signals to eight DB-9 male connectors. See [Table 2](#) for the DB-9 pinouts.

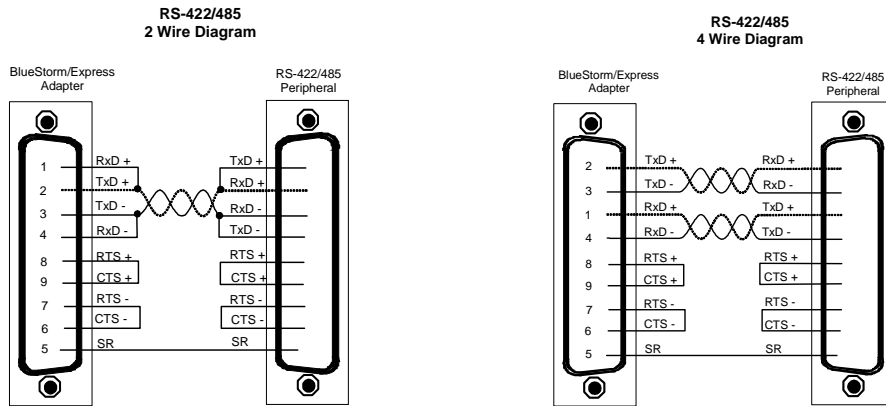

Figure 9: RS-422/485 wiring diagram (BlueStorm/Express only)

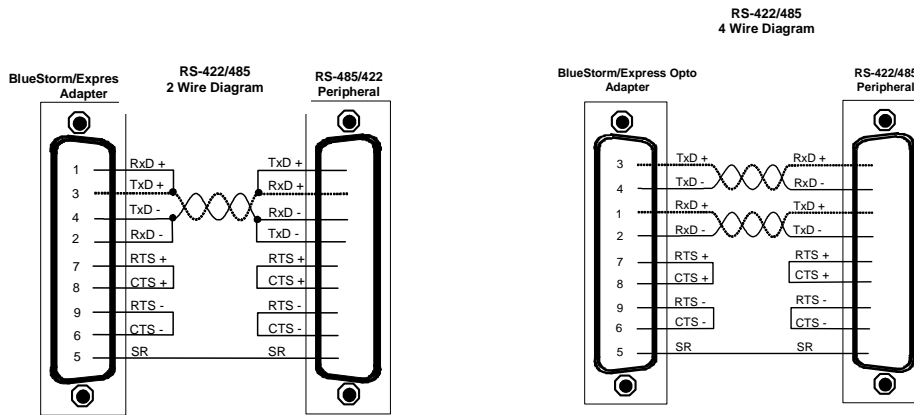

Figure 10: RS-422/485 wiring diagram (BlueStorm/Express Opto only)

Hardware Installation

Installing the BlueStorm/Express into your system

Turn off the power to your computer and open it to expose the expansion slots (consult your system's documentation for more information on this procedure).

Choose an available PCI Express position and gently press the card into the slot.

Software Installation

Software First Installation

Find the driver install package on your CD and run DpInst.exe in the directory. The installer will guide you through the process. The board will then be detected and installed when the board is physically added to the system. Software First installs are a great way to update existing drivers. Connect Tech provides QNX 4.X/6.X, Linux, Windows 2000/CE/XP/XP x64/XPe/Server 2003/Server 2003 x64, and Vista support for BlueStorm/Express.

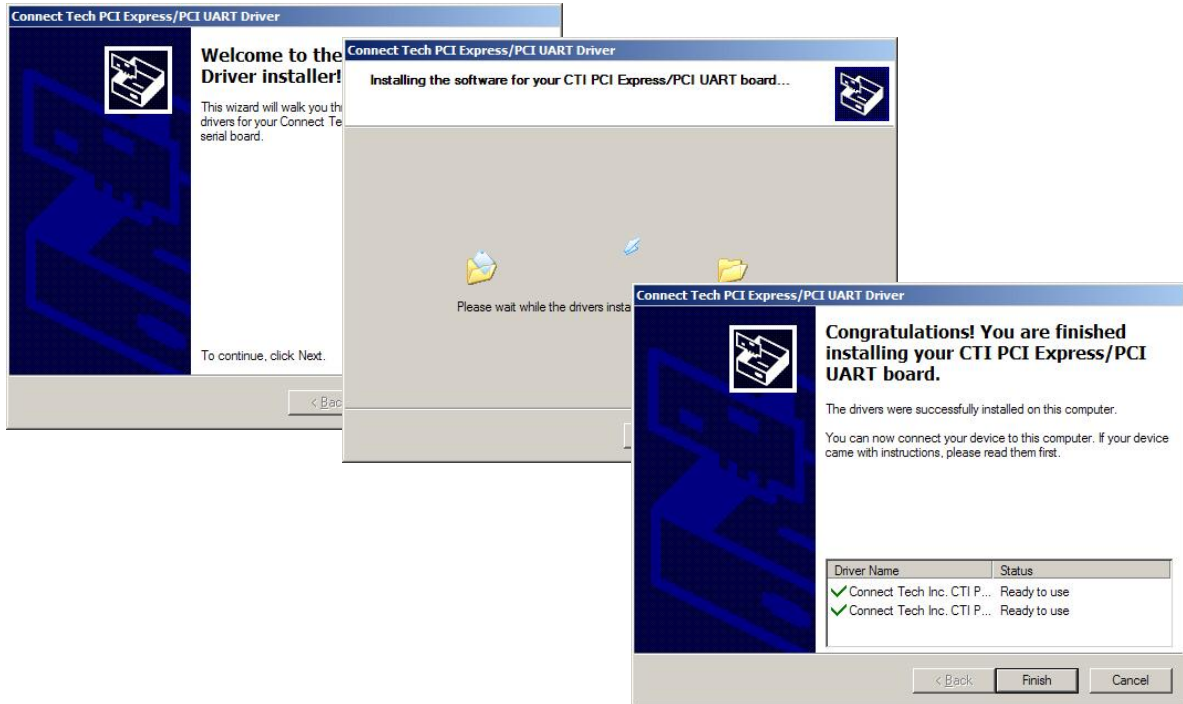

Hardware First Installation

The BlueStorm/Express provides support for QNX 4.X/6.X, Linux, Windows 2000/CE/XP/XP x64/XPe/Server 2003/Server 2003 x64 and Vista. Please refer to the **readme.txt** files found in the appropriate directories on the CD containing drivers and documentation. These files contain technical tips or release notes concerning installation and configuration of the device driver. For further information concerning software installation of BlueStorm/Express products please visit the Connect Tech website at www.connecttech.com.

If you are interested in a device driver for an operating system not listed please contact the [Connect Tech Sales Department](#). Also, visit the [Download Zone](#) of the [Support Center](#) on the Connect Tech website for the latest product manuals, installation guides, diagnostic utilities and device driver software.

Windows XP Installation

The following instructions outline how to install the BlueStorm/Express to a computer running Windows XP. For other operating system installations, consult the **readme.txt** and Installation Guides available on the CD shipped with your board(s).

1. If you haven't already installed the hardware, turn off the power to your computer and open it to expose the PCI Express card edge (consult your system's documentation for more information on this step).
2. Choose an available position, and carefully press the card into place. Re-assemble the computer.
3. After installing the BlueStorm/Express, turn on your system and the **Found New Hardware Wizard** will appear.



Step 3- Found New Hardware

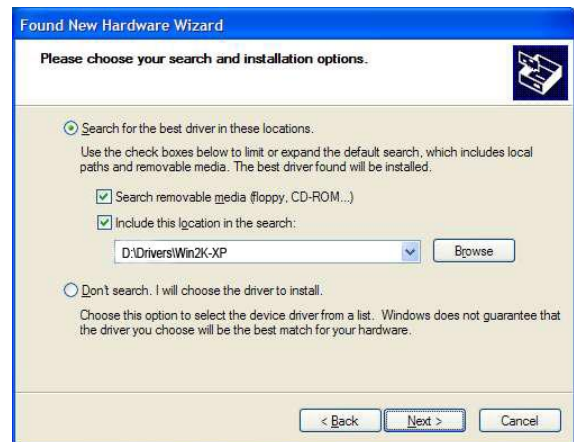

Step 5 – Search for drivers

4. Insert the BlueStorm/Express CD into your drive. Choose what you want the wizard to do by selecting **Install from a list or specific location (Advanced)**. Select **Next**.
5. Choose **Select removable media (floppy, CD-ROM)** and **Include this location in the search** and type **D:\ Drivers\Win2K-XP**, where D is the drive letter of your CD ROM. Now select **Finish**.

The **Found New Hardware Wizard** will repeat steps 3 through 5 to complete the installation of the BlueStorm/Express serial ports. Please follow the on-screen instructions. Installation is complete when no more dialogue boxes appear.

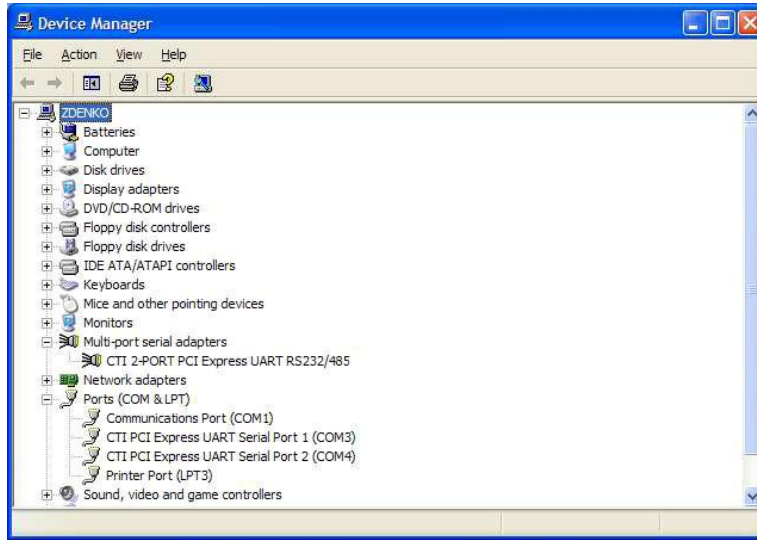

Verify the presence of BlueStorm/Express serial ports in your system by going to **Start – Control Panel – System – Hardware – Device Manager – Multi-port serial adapters**. You should see CTI X-PORT PCI Express UART RS232/485 listed.

Port Settings

You can now access individual port settings such as baud rate, data bits, parity, stop bits and flow control by choosing the appropriate CTI PCI Express UART serial port under **Ports** in the **Device Manager**. Clicking on **Advanced** while in **Port Settings** will access port settings for FIFO buffers, Baud Rate Mapping, and RS-422/485 options (see the [RS-422/485 Electrical Interface](#) section for more details.)

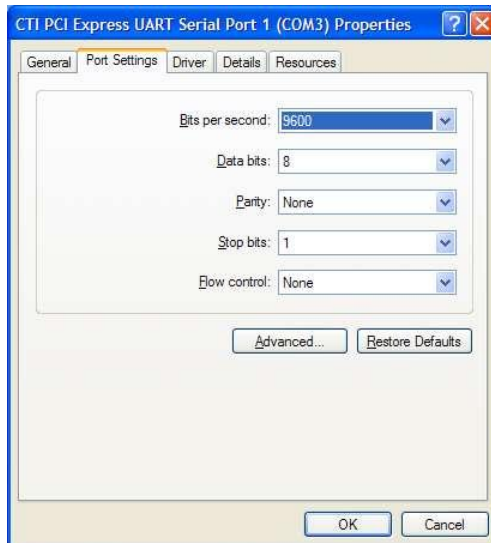

Advanced Port Settings

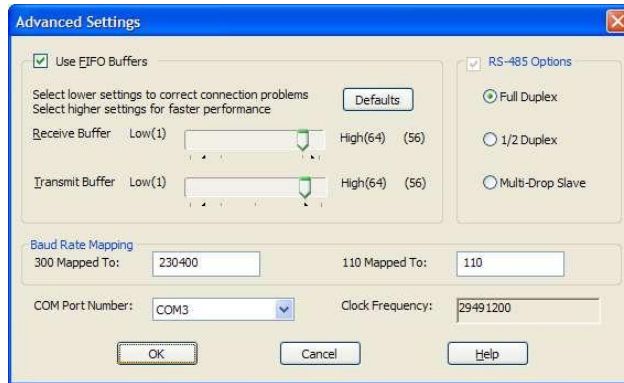

Use FIFO Buffers

For performance reasons, it is preferred that the FIFO buffers on the UART be used. When the **Use FIFO Buffers** option is enabled, the UART will be more efficient at moving data. Other functions such as flow control will be managed by the UART when this option is enabled. In some cases you may need to disable the FIFO buffers. This issue usually happens when the connected equipment cannot deal with data that is sent with minimal gaps between characters, or cases where the EscapeCommFunction (PortHandle, SETXOFF) function is used.

Receive and Transmit FIFO Settings

These sliders adjust the size of UART FIFO levels used by the CTI PCI Express UART serial ports. You obtain more buffering the further you move the slider to the right. This results in higher throughput, and lower load on the system. Note that high buffer levels can cause communication problems with some applications.

Usually the best setting is to have the receive buffer set at one notch below the highest setting and the transmit buffer at the highest setting.

Software Settings for RS-422/485

RS-422/485 ports have the following options available:

Full Duplex - In this mode, TxD & RxD are active all the time. This mode is typically used in point-to-point situations much like RS-232. RTS and CTS can be used along with the data signals.

Half Duplex - In this mode the TxD line driver is only enabled when data is transmitted, and RxD is disabled when data is being transmitted. This mode is typically used in either point-to-point (2 wire) connections OR in multi-drop (2 wire) bussed connections. CTS and RTS are not usually used with this configuration.

Multi-drop - In this mode the TxD line driver is only enabled when data is transmitted and RxD is enabled all the time. This mode is typically used in multi-drop (4 wire) connections. RTS and CTS are not usually used in this configuration.

Note: RS-485 Options are available if your BlueStorm/Express card is built or configured as RS-485, but does not mean the port is currently set this way. Check your card and ensure the jumpers are configured for RS-485 operation before changing the software setting.

Baud Rate Mapping

In some applications, high or unusual baud rates such as 230400 bps cannot be specified directly. In such a case, we provide two baud rates (110 bps and 300 bps) which can be mapped to different values if necessary.

By default 300 baud is mapped to 230400 baud. In this case, an actual baud rate will be 230400 will be set when 300 baud is specified.

If baud rate mapping is not desired specify the same baud rate in the edit box beside each of the selections. For example 300 would be set to 300 and 110 would be set to 110.

Clock Frequency

The clock frequency used by the current CTI PCI Express UART is shown in the **Clock Frequency** box.

COM Number

The driver supports the ability to change COM port names, which is also referred to as COM port mapping. Use this combo box to change the COM port number to be used for the current port.

For example specifying COM5 would set the COM name for this port to COM5.

Note: Ensure the COM name selected is not already in use or the port may not respond properly.

Specifications

Operating Environment

- Storage temperature: -40° C to 105° C
- Operating temperature: 0° C to 70° C
- Relative humidity: 5 to 95% non-condensing
- Air movement: no requirement

PCI Express Interface

- One PCI Express x1 card edge

Communications

Baud Rates

- **RS-232:** 50 bps – 921.6 Kbps
- **RS-422/485:** 50 bps – 1.8432 Mbps

Custom baud rates are also available; please contact our [Sales](#) department for information.

UARTs

BlueStorm/Express (2 and 4 port models)

- 17D152 dual UARTs with 64 byte TxD/RxD FIFO buffers

BlueStorm/Express (8 and 16 port models)

- 17V258 octal UARTs with 64 byte TxD/RxD FIFO buffers

BlueStorm/Express Opto

- 17D152 dual UARTs with 64 byte TxD/RxD FIFO buffers

BlueStorm/Express Opto (1 kV)

- 17V258 octal UART with 64 byte TxD/RxD FIFO buffers

BlueStorm/Express LP

- 17V258 octal UART with 64 byte TxD/RxD FIFO buffers

BlueStorm/Express LP Opto

- 17D152 octal UART with 64 byte TxD/RxD FIFO buffers

Surge Suppression

BlueStorm/Express (2, 4, 8, and 16 port models) and BlueStorm/Express LP

- TransGuard[®] Transient Voltage Suppression, able to withstand multiple strikes on every signal of every port
- Transient Energy dissipation 0.05 joules on every signal of every port
- Transient peak current rating 15A on every signal of every port
- EN61000-4-2/3/4 compatible

BlueStorm/Express Opto (1 kV) (Ports 1-4 only)

- TransGuard[®] Transient Voltage Suppression, able to withstand multiple strikes on every signal of every port
- Transient Energy dissipation 0.05 joules on every signal of every port
- Transient peak current rating 15A on every signal of every port
- EN61000-4-2/3/4 compatible

Optical Isolation

BlueStorm/Express Opto and BlueStorm/Express LP Opto

- 3kV peak to peak on every signal of every port

BlueStorm/Express Opto (1 kV)

- 1kV peak to peak on every signal of ports 5 thru 8. Ports 1 through 4 are non-isolated

Dimensions

BlueStorm/Express (2 and 4 port models)

- Length: 10.86 cm, 4.275 inches
- Height: 10.92 cm, 4.300 inches

BlueStorm/Express (8 and 16 port models)

- Length: 14.699 cm, 5.775 inches
- Height: 11.1125 cm, 4.375 inches

BlueStorm/Express Opto (2 and 4 port as well as 8 port (1 kV) models)

- Length: 14.699 cm, 5.775 inches
- Height: 11.049 cm, 4.350 inches

BlueStorm/Express LP

- Length: 14.669 cm, 5.755 inches
- Height: 6.891 cm, 2.713 inches

BlueStorm/Express LP Opto

- Length: 15.7 cm, 6.2 inches
- Height: 6.9 cm, 2.7 inches

Certification

Connect Tech Inc. declares that the product(s) covered by the contents of this manual have been tested and found compliant with the below listed standards as required by the Electromagnetic Compatibility (EMC) Directive for General Immunity Compliance, EN 50 0082.1:1997

EN 55022 Conducted and Radiated emissions
CISPR 22 Class A

EN 55024 Immunity to Disturbances

EN 61000-4-2		EN 61000-4-4
EN 61000-4-3		EN 61000-4-6

The above satisfy the requirements of:

USA: FCC – CFR47, Part 15, part 2
Canada: ICES-003
Europe: EMC Directive
Japan: VCCI
Australia/New Zealand: AS/NZS



The above agency conformances were met by independent laboratory testing of Connect Tech Inc. product(s) with shielded cables, with metal hoods, attached to either the terminating connectors or cable assemblies supplied with the product(s). Failure to follow good EMC/EMI compliant cabling practices may produce more emissions or less immunity than were obtained in laboratory measurements.

Operation of this equipment in a residential area may cause unacceptable interference to radio and TV reception, requiring the user to take whatever steps necessary to correct the interference.

