

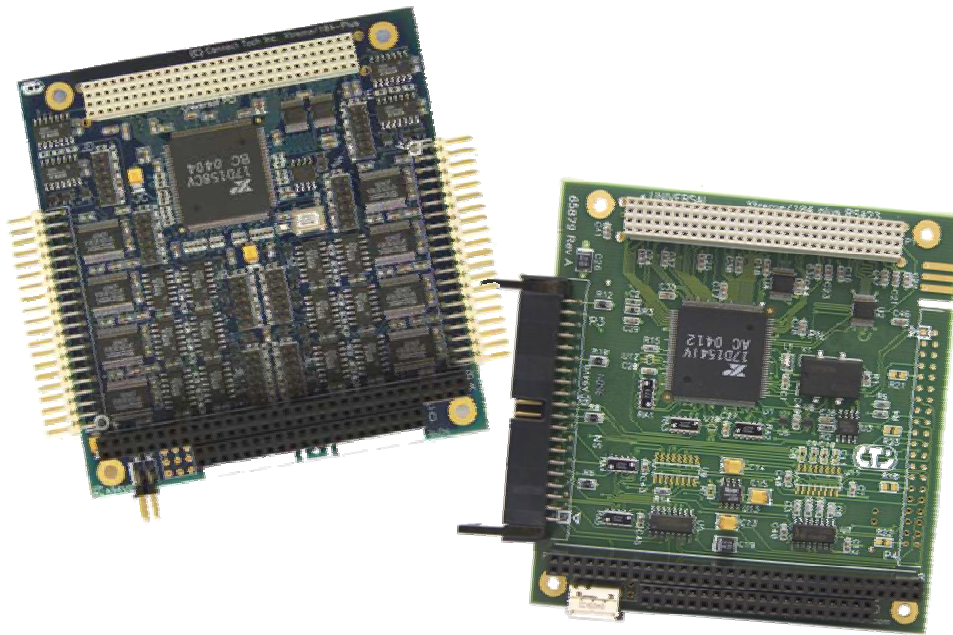

Connect Tech Inc.
Industrial Strength Communications

Xtreme/104-Plus



Connect Tech Inc
42 Arrow Road
Guelph, Ontario
N1K 1S6

Tel: 519-836-1291
Toll: 800-426-8979 (North America only)
Fax: 519-836-4878
Email: sales@connecttech.com
support@connecttech.com
Web: www.connecttech.com

Limited Lifetime Warranty

Connect Tech Inc. provides a Lifetime Warranty for all Connect Tech Inc. products. Should this product, in Connect Tech Inc.'s opinion, fail to be in good working order during the warranty period, Connect Tech Inc. will, at its option, repair or replace this product at no charge, provided that the product has not been subjected to abuse, misuse, accident, disaster or non Connect Tech Inc. authorized modification or repair.

You may obtain warranty service by delivering this product to an authorized Connect Tech Inc. business partner or to Connect Tech Inc. along with proof of purchase. Product returned to Connect Tech Inc. must be pre-authorized by Connect Tech Inc. with an RMA (Return Material Authorization) number marked on the outside of the package and sent prepaid, insured and packaged for safe shipment. Connect Tech Inc. will return this product by prepaid ground shipment service.

The Connect Tech Inc. Lifetime Warranty is defined as the serviceable life of the product. This is defined as the period during which all components are available. Should the product prove to be irreparable, Connect Tech Inc. reserves the right to substitute an equivalent product if available or to retract Life Time Warranty if no replacement is available.

The above warranty is the only warranty authorized by Connect Tech Inc. Under no circumstances will Connect Tech Inc. be liable in any way for any damages, including any lost profits, lost savings or other incidental or consequential damages arising out of the use of, or inability to use, such product.

Copyright Notice

The information contained in this document is subject to change without notice. Connect Tech Inc. shall not be liable for errors contained herein or for incidental consequential damages in connection with the furnishing, performance, or use of this material. This document contains proprietary information that is protected by copyright. All rights are reserved. No part of this document may be photocopied, reproduced, or translated to another language without the prior written consent of Connect Tech, Inc.

Copyright © 1997 - 2006 by Connect Tech, Inc.

Trademark Acknowledgment

Connect Tech, Inc. acknowledges all trademarks, registered trademarks and/or copyrights referred to in this document as the property of their respective owners.

Not listing all possible trademarks or copyright acknowledgments does not constitute a lack of acknowledgment to the rightful owners of the trademarks and copyrights mentioned in this document.

Table of Contents

Limited Lifetime Warranty	2
Copyright Notice	2
Trademark Acknowledgment	2
Table of Contents	3
List of Figures	4
List of Tables	4
Customer Support Overview	5
Contact Information	5
Introduction	6
Features	6
Xtreme/104-Plus Diagrams	7
Xtreme/104-Plus Installation Overview	9
Hardware Installation	9
Installing the Xtreme/104-Plus into your system	9
Hardware Configuration	9
Interrupts and Memory Address Selection	9
ID Selection	10
ID selection using the Rotary Switch	10
ID Selection using the Jumper Block	10
Electrical Interfaces	11
RS-232 Electrical Interface	11
RS-422/485 Electrical Interface	11
Full Duplex Mode	11
Half Duplex Mode	11
Multi-drop Slave Mode	11
Line Bias/Termination	11
Jumper Block Settings	12
Connectors/Pinouts	13
Electrical Interfaces (RS-232/422/485/TTL models)	17
RS-232/TTL Electrical Interface	17
RS-422/485 Electrical Interface	17
Jumper Block Settings	17
Software Installation	19
Software Installation	19
Windows XP Installation	19
Port Settings	20
Specifications	21
Operating Environment	21
Power Requirements	21
PC Bus Interface	21
Dimensions	21
Communications	21
Baud Rates	21
UARTs	21
Control Signals	21
Certification	21

List of Figures

Figure 1: Xtreme/104-Plus RS-232/422/485 model hardware components	7
Figure 2: Xtreme/104-Plus RS-423 model hardware components	7
Figure 3: Xtreme/104-Plus RS-232/422/485/TTL Models	8
Figure 4: Rotary switch ID selection	10
Figure 5: Jumper settings for ID selection	10
Figure 6: Example of various jumper block settings for four-port RS-232/422/485 models	12
Figure 7: 40 pin connector: Pin numbering	13
Figure 8: Typical cabling example for RS-423 models	16
Figure 9: Examples of various jumper block settings for RS-232/422/485/TTL models	17

List of Tables

Table 1: I/O Signal Assignments for RS-423 models	13
Table 2: I/O Signal Assignments for RS-232/422/485 Models (see Figure 1 for Port Numbering)	14
Table 3: DB-9 male fan-out cable pinouts	15
Table 4: RS-232/TTL Px1 right angled header pinouts (CAB104 compatible)	15
Table 5: RS-485 Px2 vertical header pinouts	15
Table 6: Multi-Purpose I/O (MPIO) header pinout (direct connection to UART)	16

Customer Support Overview

If you experience difficulties after reading the manual and/or using the product, contact the Connect Tech reseller from which you purchased the product. In most cases the reseller can help you with product installation and difficulties.

In the event that the reseller is unable to resolve your problem, our highly qualified support staff can assist you. Our support section is available 24 hours a day, 7 days a week on our website at: www.connecttech.com/sub/support/support.asp. See the contact information section below for more information on how to contact us directly. Our technical support is always free.

Contact Information

We offer three ways for you to contact us:

Mail/Courier

You may contact us by letter at:

Connect Tech Inc.
Technical Support
42 Arrow Road
Guelph, Ontario
Canada N1K 1S6

Email/Internet

You may contact us through the Internet. Our email and URL addresses on the Internet are:

sales@connecttech.com
support@connecttech.com
www.connecttech.com

Note:

Please go to the [Download Zone](#) or the [Knowledge Database](#) in the [Support Center](#) on the Connect Tech website for product manuals, installation guides, device driver software and technical tips.

Submit your technical support questions to our customer support engineers via the [Support Center](#) on the Connect Tech website.

Telephone/Facsimile

Technical Support representatives are ready to answer your call Monday through Friday, from 8:30 a.m. to 5:00 p.m. Eastern Standard Time. Our numbers for calls are:

Telephone: 800-426-8979 (North America only)
Telephone: 519-836-1291 (Live assistance available 8:30 a.m. to 5:00 p.m. EST, Monday to Friday)
Facsimile: 519-836-4878 (on-line 24 hours)

Introduction

Connect Tech's Xtreme/104-Plus family combines the best of the Universal PCI bus with the rugged and compact form factor of PC/104.

PCI 2.3 and PC/104-Plus 2.0 compliant, the modular Xtreme/104-Plus cards include a PC/104 pass-through connector option for compatibility with legacy PC/104 cards.

The Xtreme/104-Plus offers independent port configuration for baud rate, and data bit options of 5, 6, 7 and 8 as well as 1, 1.5 and 2 stop bits. Select between odd and even parity.

The Xtreme/104-Plus is perfect for embedded applications such as industrial PCs, kiosks, military systems, aerospace, medical systems, POS devices and any system requiring fast data transfer speeds and a rugged, compact form factor. These self-stacking cards are low on power consumption and function in industrial temperature conditions.

Features

- Universal PC/104-Plus adapter
- PCI 2.3 and PC/104-Plus compliant
- 2 port model: 2 ports RS-423
- 4 port models: 4 ports RS-423 or 4 ports jumper selectable RS-232/422/485
- 8 port models: 8 ports jumper selectable RS-232/422/485
- 8 ports jumper selectable RS-232/422/485/TTL model
- Supports full duplex, half duplex and multi-drop communication modes in RS-422/485 (full duplex only in TTL model)
- TTL model has the ability to disable ports when not in use
- Maximum data speeds of 115.2 Kbps (RS-423), 921.6 Kbps (RS-232/TTL) and 1.843 Mbps (RS-422/485)
- Operating temperature range of -40°C to 85°C, storage temperature of -40°C to 125°C
- Each port can be configured independently for baud rate, parity, data and stop bits
- High performance PCI UARTs
- PC/104 pass-through connectors installed for compatibility with legacy PC/104 cards on select models
- Software support for Windows, QNX, Linux
- Available signals
 - RS-423 Model:*
 - RS-423: TxD-, TxDRef, RxD+/-, RTS-, RTSRef, CTS+/-
 - RS-232/422/485 Models:*
 - RS-232: TxD, RxD, RTS, CTS, RI, DTR, DSR, DCD and Signal Ground (SG)
 - RS-422/485: TxD+/-, RxD+/-, RTS+/-, CTS+/- and Signal Return (SR)
 - RS-232/422/485/TTL Models:*
 - RS-232/TTL: TxD, RxD, RTS, CTS, RI, DTR, DSR, DCD, Signal Ground (SG), +5V
 - RS-422/485: TxD+/-, RxD+/- and Signal Return (SR)
- Multilayer PCB built with EMI reduction techniques
- Built with low power CMOS components
- PCI plug and play -- no jumpers to set for memory or interrupt configuration

Xtreme/104-Plus Diagrams

Figure 1: Xtreme/104-Plus RS-232/422/485 model hardware components

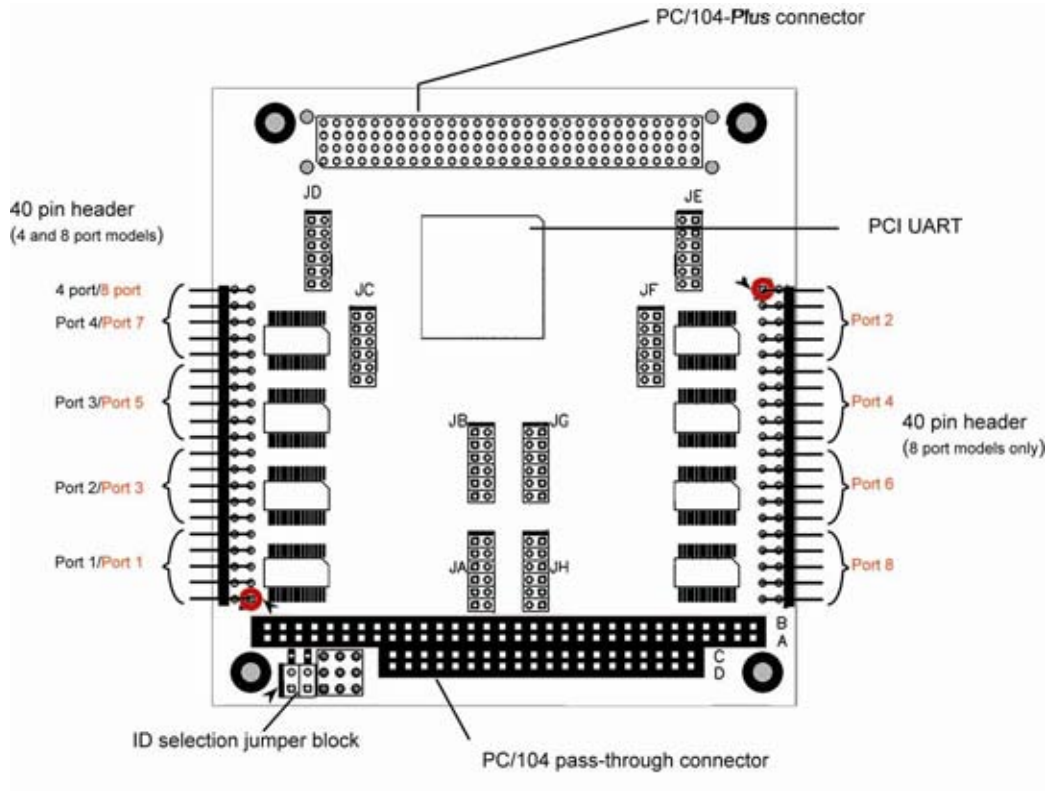

Figure 2: Xtreme/104-Plus RS-423 model hardware components

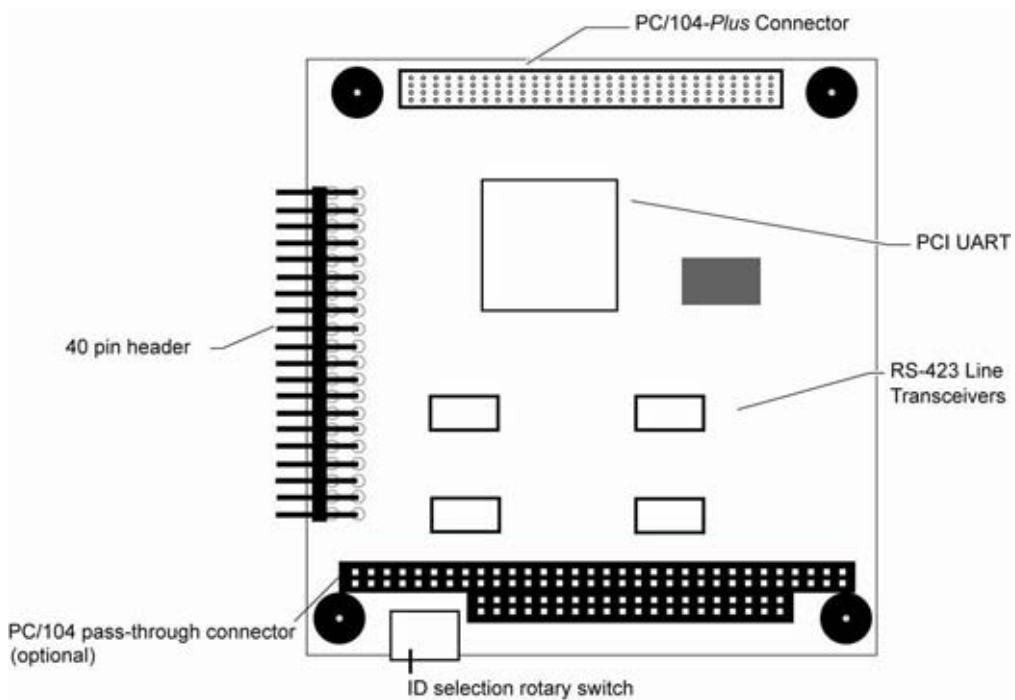
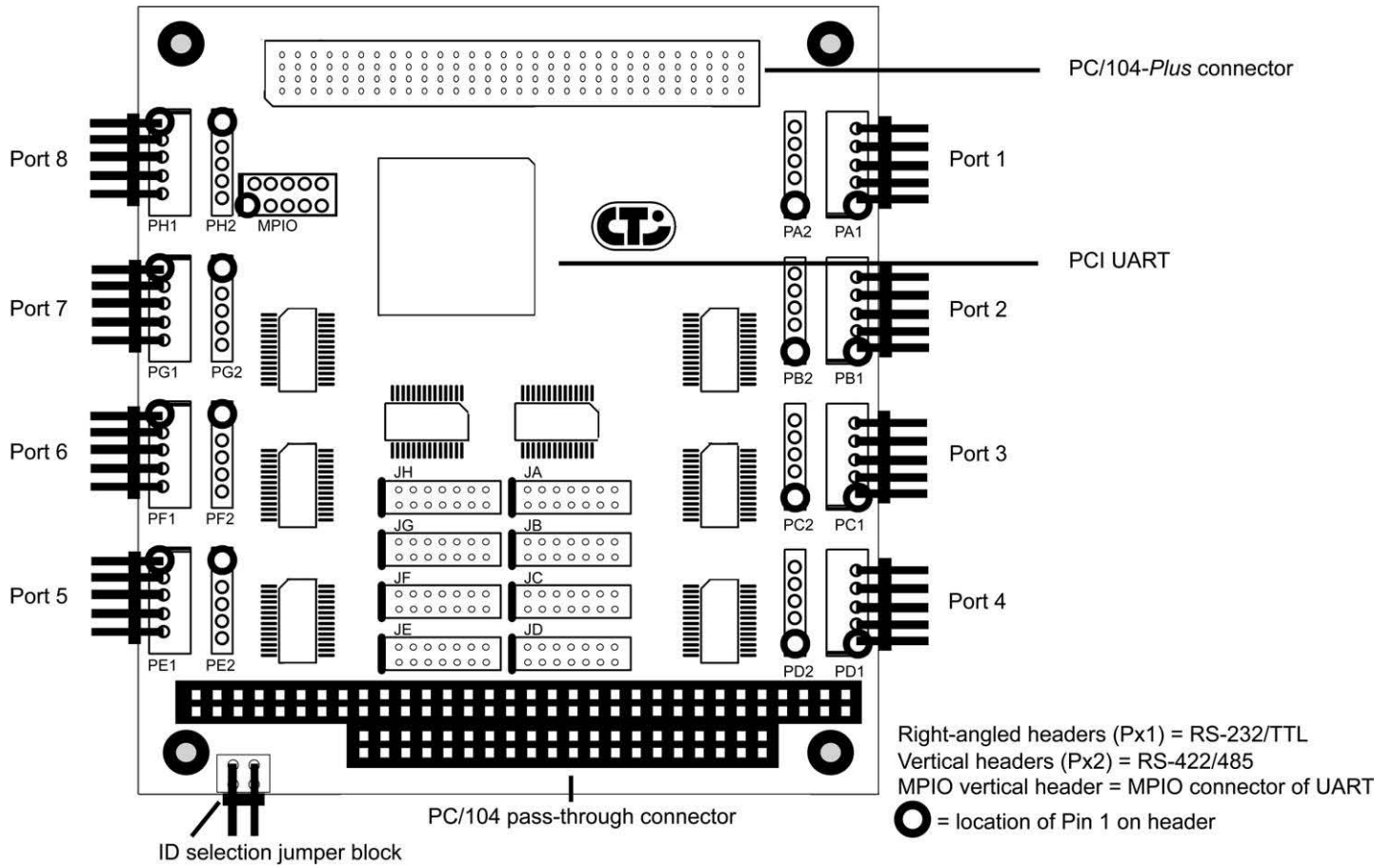

Figure 3: Xtreme/104-Plus RS-232/422/485/TTL Models



Note: Configuration information for the RS-232/422/485/TTL model, including jumper settings and pinouts, is located in [Electrical Interfaces \(RS-232/422/485/TTL models\)](#).

Xtreme/104-Plus Installation Overview

Before you begin, take a moment to ensure your package includes the components that ship with your product. These components should include:

- One Xtreme/104-Plus adapter
- One CD containing software and documentation
- One DB-9 male fan-out cable (optional)

If any of these components is missing, contact [Connect Tech](#) (see more [Contact Details](#)) or your reseller.

There are three stages to installing your Xtreme/104-Plus:

1. [Hardware Configuration](#)
Interrupts and Memory selection will be set by the host computer's BIOS. This section outlines jumper settings and the ID selection process.
2. [Hardware Installation](#)
Installation involves the physical connection of the Xtreme/104-Plus within your computer's PC/104-Plus stack. (Please note that you should configure any jumper settings, such as [ID](#) or [electrical interface](#), if required, prior to installing the board.)
3. [Software/driver installation](#)
Load the appropriate driver for your Operating System, as found on the accompanying CD. Installation guides are also available on the CD to aid you in this process.

Hardware Installation

Installing the Xtreme/104-Plus into your system

Turn off the power to your computer and open it to expose the expansion slots (consult your system's documentation for more information on this procedure).

Choose an available position in the PC/104-Plus stack, and set the ID jumpers or rotary switch accordingly (see ID Selection). Insert the Xtreme/104-Plus adapter and re-assemble the stack.

Hardware Configuration

Interrupts and Memory Address Selection

The Xtreme/104-Plus board is a PCI card, so the host computer's BIOS will automatically set interrupts and memory addresses when you reboot after installation.

ID Selection

Up to four Xtreme/104-Plus boards can reside within a single PC/104-Plus module stack. Each card within the stack must have a unique ID ranging from zero to three.

Depending on the model of your Xtreme/104-Plus, you will be required to set either a pair of jumpers or a rotary switch to specify where your card is located within the stack. (Ensure that no two boards share an ID number.)

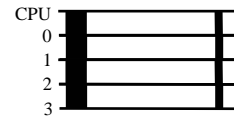

In systems designed prior to the PC/104-Plus 2.0 specification, the fourth ID was reserved for target only devices and did not support bus mastering. Since the Xtreme/104-Plus is not a bus mastering device, we would recommend an assignment of ID 3. This leaves three of the IDs in the PC/104-Plus stack available for bus mastering devices.

In systems designed post PC/104-Plus 2.0 specification, all four IDs support bus mastering, so there is no advantage to setting the Xtreme/104-Plus ID to 3. Regardless of which PC/104-Plus specification version the system is using, the Xtreme/104-Plus will work with any ID selected as long as no other device in the system is using that ID as well.

ID selection using the Rotary Switch

If your Xtreme/104-Plus is equipped with a rotary switch, turn the knob on the switch so that the arrow points at the ID you would like to use. (See [Figure 4](#) for the location of the rotary switch on the board).

Use the following settings to set your Xtreme/104-Plus adapter's location (or ID) within the stack:

Figure 4: Rotary switch ID selection

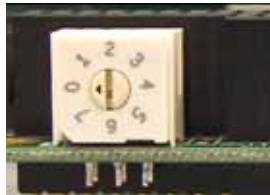

Module Slot	Switch Position
1	0 or 4
2	1 or 5
3	2 or 6
4	3 or 7

ID Selection using the Jumper Block

If your Xtreme/104-Plus is equipped with a jumper block for ID selection, set your board's location by changing jumper positions. [Figure 5](#) depicts the jumper settings required for each ID.

The jumpers remain unpopulated for an ID of zero. Populate the left jumper for an ID of one, right jumper for an ID of two, and populate both for an ID of three.

Figure 5: Jumper settings for ID selection

ID Selector Jumper positions (RS-232/422/485 models)

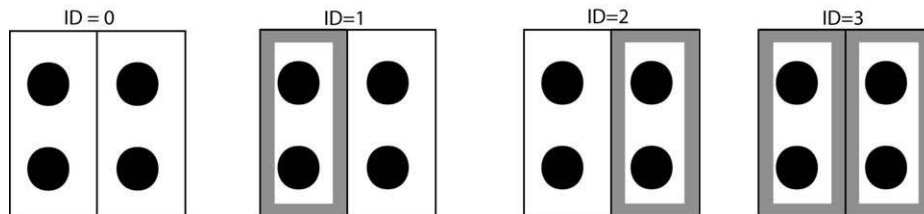

Electrical Interfaces (RS-232/422/485 and RS-423 models)

RS-232 Electrical Interface

This is the default setting for the interface selectable Xtreme/104-Plus. To operate a port in RS-232 mode, no jumpers are set on the corresponding jumper block.

RS-422/485 Electrical Interface

The Xtreme/104-Plus RS-232/422/485 adapter supports three modes of RS-422/485 communication, as outlined below.

(See [Figure 6](#) to see examples of jumper settings.)

Full Duplex Mode

In this mode, TxD+/- & RxD+/- are being driven to a known level all the time. This mode is typically used in point-to-point situations much like RS-232. It is the default setting.

Half Duplex Mode

In this mode the TxD+/- line driver is enabled only when data is transmitted and RxD+/- is disabled when data is being transmitted. This mode is typically used in either point-to-point 2-wire connections OR in multi-drop 2-wire bus connections. This mode requires software setup in Control Panel – System – Hardware – Device Manager – Ports – CTI PCI UART. Click on Advanced under Port Settings after the driver is installed.

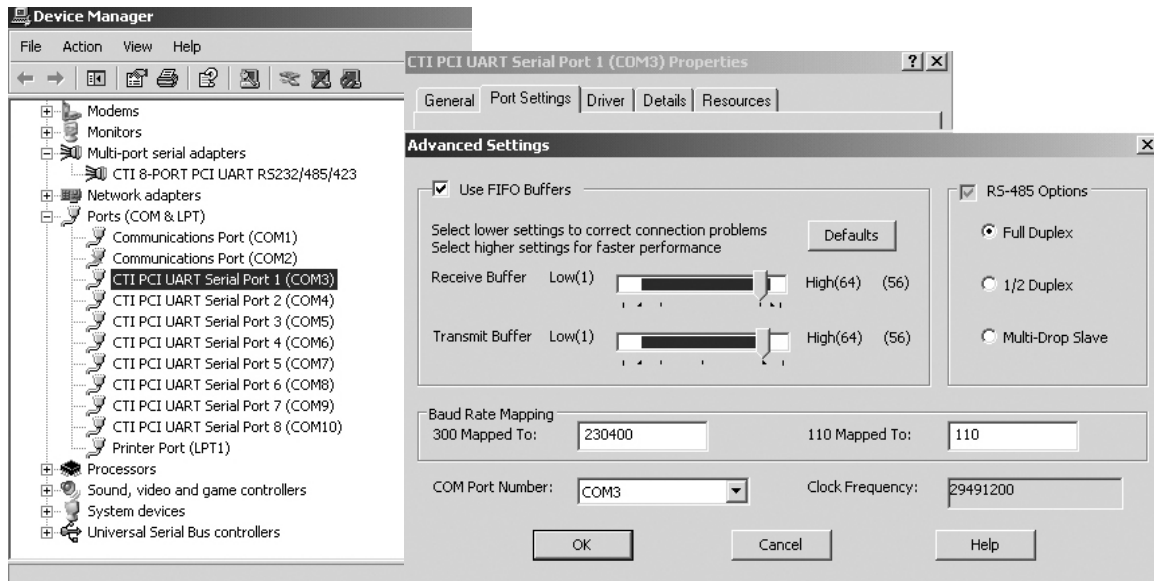

Multi-drop Slave Mode

In this mode the TxD+/- line driver is enabled only when data is transmitted and RxD+/- is enabled all the time. This mode is typically used in multi-drop 4-wire connections. This mode requires software setup in Control Panel – System Properties – Hardware - Device Manager – Ports – CTI PCI UART. Click on Advanced under Port Settings. (See Half Duplex Mode above.)

Line Bias/Termination

The RS-422/485 transceivers, both transmit and receive are optionally biased to produce a line level mark condition through jumper selectable resistors. These options are typically used in multi-drop 4-wire connections.

Jumper Block Settings

The following jumper block diagram depicts typical settings on a four-port selectable Xtreme/104-Plus. Jumper blocks JA, JB, JC and JD control ports 1 through 4, respectively.

Figure 6: Example of various jumper block settings for four-port RS-232/422/485 models

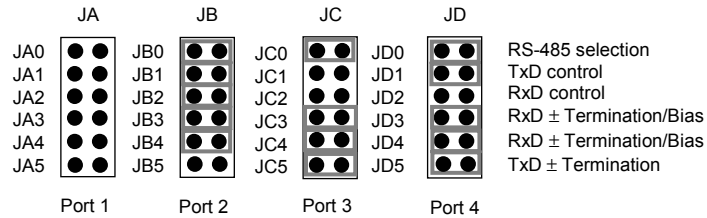

In this example, port 1 is set to RS-232, port 2 is set to RS-422/485 half duplex, port 3 is set to RS-422/485 full duplex, and port 4 is set to RS-422/485 multi-drop slave.

RS-485 Selection: Install this jumper to configure a port for RS-422/485 mode. If the jumper is not installed, the port will function in RS-232 mode.

TxD Control: Install this jumper to enable the RS-485 transmitter only when sending data. This mode is useful for half-duplex operation when only one device is allowed to send data at a time. If the jumper is not installed, the transmitter will always drive the line to an idle state when not sending data.

RxD control: Install this jumper to enable the RS-485 receiver only when NOT transmitting data. This is useful for half-duplex operation to prevent the transmitting device from receiving its own data as it sends. If this jumper is not installed, the receiver is always enabled and ready to receive data.

RxD ± Termination/Bias: Install this pair of jumpers to enable a 150 ohm terminator across the RxD+ and RxD- pins for the corresponding port. A biasing network is also enabled that drives the receiver to an inactive or safe mode. The receiver can still receive data from another device and the biasing helps to prevent the reception of data generated by noise on the transmission line. The two jumpers for RxD termination/bias must be installed and removed as a pair.

TxD ± Termination: Install this jumper to enable a 150 ohm resistor across the TxD+ and TxD- pins of the corresponding port.

Important port numbering note:

Due to differences between the quad and octal UARTS, the port numbering for eight port models differs from the numbering for four port models.

Jumper blocks JA through JD control ports 1 through 4, respectively, on four port models.

On eight port models, jumper blocks JA through JD control the odd numbered ports and JE through JH control the even numbered ports, as follows:

JA = Port 1, JB = Port 3, JC = Port 5, JD = Port 7
 JE = Port 2, JF = Port 4, JG = Port 6, JH = Port 8.

[Half Duplex](#) and [Multi-drop Slave](#) modes require you to select the appropriate mode via software. Please refer to the readme.txt files found in the appropriate directories on the Xtreme/104-Plus CD.

Connectors/Pinouts

Figure 7: 40 pin connector: Pin numbering

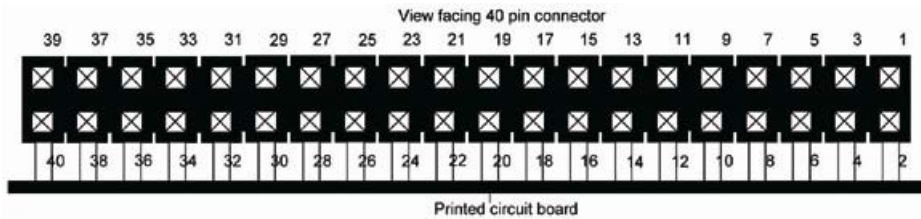

Table 1: I/O Signal Assignments for RS-423 models

Header Port Number	Header Pin Number	RS-423	Direction
1	1	RxD+	Input
	2	CTS-	Input
	3	RxD-	Input
	4	RTSRef (RTS+)	Signal Reference
	5	TxDRef (TxD+)	Signal Reference
	6	CTS+	Input
	7	TxD-	Output
	8	RTS-	Output
	9	GND	Ground [1]
	10	N/C	No connection
2	11	RxD+	Input
	12	CTS-	Input
	13	RxD-	Input
	14	RTSRef (RTS+)	Signal Reference
	15	TxDRef (TxD+)	Signal Reference
	16	CTS+	Input
	17	TxD-	Output
	18	RTS-	Output
	19	GND	Ground [1]
	20	N/C	No connection
3	21	RxD+	Input
	22	CTS-	Input
	23	RxD-	Input
	24	RTSRef (RTS+)	Signal Reference
	25	TxDRef (TxD+)	Signal Reference
	26	CTS+	Input
	27	TxD-	Output
	28	RTS-	Output
	29	GND	Ground [1]
	30	N/C	No connection
4	31	RxD+	Input
	32	CTS-	Input
	33	RxD-	Input
	34	RTSRef (RTS+)	Signal Reference
	35	TxDRef (TxD+)	Signal Reference
	36	CTS+	Input
	37	TxD-	Output
	38	RTS-	Output
	39	GND	Ground [1]
	40	N/C	No connection

Note:

[1] 47 Ω to GND. Ground is connected to the DC ground by a 47 Ω resistor to reduce ground loop current.

Table 2: I/O Signal Assignments for RS-232/422/485 Models (see [Figure 1](#) for Port Numbering)

Header Port No. (4 port models)	Header Port No. (8 port models)	Pin No.	RS-232	Direction	RS-422/485	Direction
1	1 or 2	1	DCD	Input	RxD+	Input
		2	DSR	Input	CTS-	Input
		3	RxD	Input	RxD-	Input
		4	RTS	Output	RTS+	Output
		5	TxD	Output	TxD+	Output
		6	CTS	Input	CTS+	Input
		7	DTR	Output	TxD-	Output
		8	RI	Input	RTS-	Output
		9	SG	Signal Ground	SR	Signal Reference
		10	N/C	No Connection	N/C	No Connection
2	3 or 4	11	DCD	Input	RxD+	Input
		12	DSR	Input	CTS-	Input
		13	RxD	Input	RxD-	Input
		14	RTS	Output	RTS+	Output
		15	TxD	Output	TxD+	Output
		16	CTS	Input	CTS+	Input
		17	DTR	Output	TxD-	Output
		18	RI	Input	RTS-	Output
		19	SG	Signal Ground	SR	Signal Reference
		20	N/C	No Connection	N/C	No Connection
3	5 or 6	21	DCD	Input	RxD+	Input
		22	DSR	Input	CTS-	Input
		23	RxD	Input	RxD-	Input
		24	RTS	Output	RTS+	Output
		25	TxD	Output	TxD+	Output
		26	CTS	Input	CTS+	Input
		27	DTR	Output	TxD-	Output
		28	RI	Input	RTS-	Output
		29	SG	Signal Ground	SR	Signal Reference
		30	N/C	No Connection	N/C	No Connection
4	7 or 8	31	DCD	Input	RxD+	Input
		32	DSR	Input	CTS-	Input
		33	RxD	Input	RxD-	Input
		34	RTS	Output	RTS+	Output
		35	TxD	Output	TxD+	Output
		36	CTS	Input	CTS+	Input
		37	DTR	Output	TxD-	Output
		38	RI	Input	RTS-	Output
		39	SG	Signal Ground	SR	Signal Reference
		40	N/C	No Connection	N/C	No Connection

Table 3: DB-9 male fan-out cable pinouts

Pin #	RS-232		RS-422/485		RS-423 [1]	
	Signal	Direction	Signal	Direction	Signal	Direction
1	DCD	Input	RxD+	Input	RxD+	Input
2	RxD	Input	RxD-	Input	RxD-	Input
3	TxD	Output	TxD+	Output	TxDRef (TxD+)	Signal Reference
4	DTR	Output	TxD-	Output	TxD-	Output
5	SG	Signal Ground	SR	Signal Reference	GND	Ground [2]
6	DSR	Input	CTS-	Input	CTS-	Input
7	RTS	Output	RTS+	Output	RTSRef (RTS+)	Signal Reference
8	CTS	Input	CTS+	Input	CTS+	Input
9	RI	Input	RTS-	Output	RTS-	Output

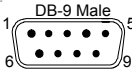

DB-9 Male

Notes:

[1] When CAB8104 cable assembly is attached.

[2] 47Ω to GND. Ground is connected to the DC ground by a 47Ω resistor to reduce ground loop current

Table 4: RS-232/TTL Px1 right angled header pinouts (CAB104 compatible)(See [Figure 3](#) for Port numbering and locations)

Pin #	RS-232/TTL signal	Direction
1	DCD	Input
2	DSR	Input
3	RxD	Input
4	RTS	Output
5	TxD	Output
6	CTS	Input
7	DTR	Output
8	RI	Input
9	SG	Signal Ground
10	+5V	supply to external devices

Note: Total current draw on +5V pins of all ports must not exceed 1A.

Table 5: RS-485 Px2 vertical header pinouts(See [Figure 3](#) for Port header numbering and locations)

Pin #	RS-485 signal	Direction
1	TxD+	Output
2	TxD-	Output
3	RxD+	Input
4	RxD-	Input
5	SR	Signal Reference

Table 6: Multi-Purpose I/O (MPIO) header pinout (direct connection to UART)

(See [Figure 3](#) for location of MPIO header and pin numbering)

Pin #	Signal
1	MPIO1
2	MPIO2
3	MPIO3
4	MPIO4
5	MPIO5
6	MPIO6
7	MPIO7
8	MPIO8
9	GND
10	GND

Figure 8: Typical cabling example for RS-423 models

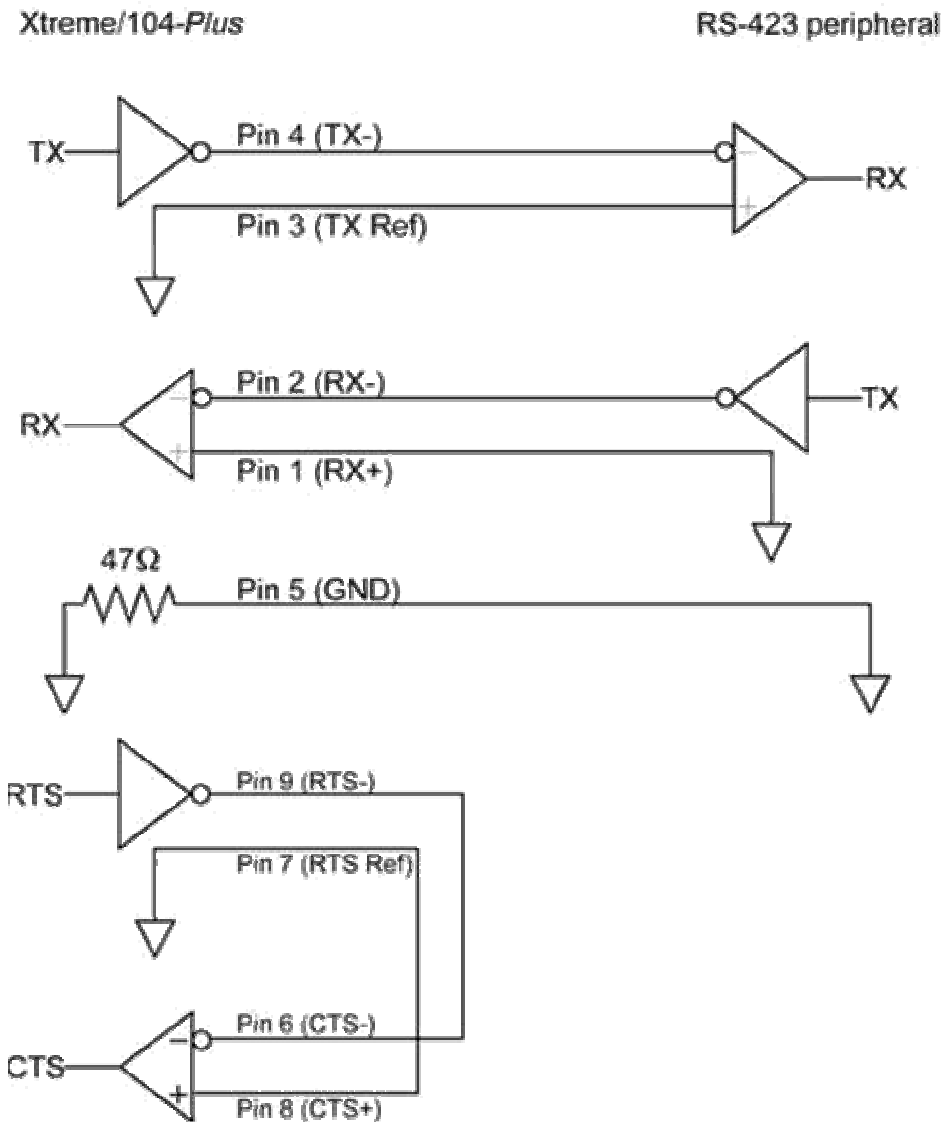

Electrical Interfaces (RS-232/422/485/TTL models)

RS-232/TTL Electrical Interface

The following control signals are available to ports configured for RS-232 and TTL mode: TxD, RxD, RTS, CTS, RI, DTR, DSR, DCD, SG (Signal Ground) and +5V. See [Figure 3](#) for the location of Px1 RS-232/TTL port headers. See [Figure 9](#) for information on configuring ports for RS-232 or TTL mode. (Note: Current draw on +5V pins of all ports must not exceed 1 Amp.)

RS-422/485 Electrical Interface

In this mode, the port will communicate in RS-422 and RS-485 full duplex using the vertical Px2 headers. (See [Figure 3](#) for the location of Px2 headers). The following control signals are available: TxD₊, RxD₊ and SR (Signal Return). See [Figure 9](#) for information on configuring ports for RS-422/485 mode.

Jumper Block Settings

The following jumper blocks correspond to the following ports:

JA = Port 1	JE = Port 5
JB = Port 2	JF = Port 6
JC = Port 3	JG = Port 7
JD = Port 4	JH = Port 8

The pin functions are outlined in the following diagram:

Figure 9: Examples of various jumper block settings for RS-232/422/485/TTL models

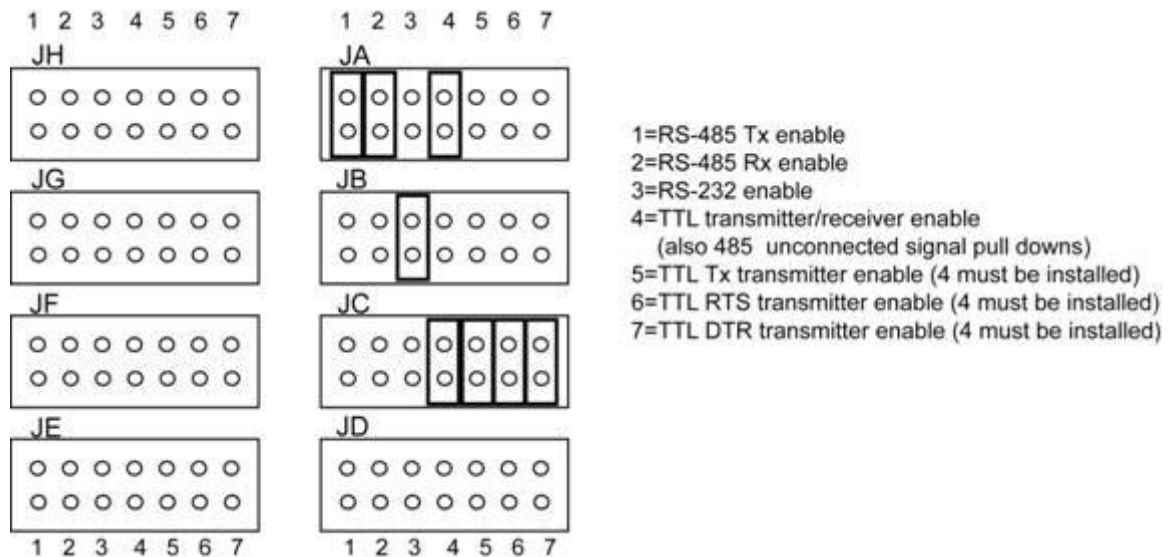

In the example in Figure 2, port 1 (JA) is configured for RS-422/485 full duplex, port 2 (JB) is configured for RS-232, port 3 (JC) is configured for TTL, and ports 4 to 8 (JD to JH) are disabled.

When all jumpers are removed, the corresponding ports are completely disabled. The UART will receive no data from these ports, even if an external source is driving the headers.

NOTE: There are 8 solder jumpers on the back of the board that correspond to the vertical (Px2) headers on the front of the board. (See [Figure 3](#) for location of Px2 headers). If necessary, you can ensure TxD_{+/} pins on specified vertical headers remain active, even if the board is not in RS-422/485 mode or is disabled, by shorting the appropriate jumper.

Software Installation

The Xtreme/104-Plus provides support for QNX 4.X/6.X, Linux, Windows 2000/XP/XPe, and Windows NT. Please refer to the readme.txt files found in the appropriate directories on the Xtreme/104-Plus CD containing drivers and documentation. These files contain technical tips or release notes concerning installation and configuration of the device driver. For further information concerning software installation of Xtreme/104-Plus products please visit the Connect Tech website at www.connecttech.com.

If you are interested in a device driver for an operating system not listed please contact the [Connect Tech Sales Department](#). Also, visit the [Download Zone](#) of the [Support Center](#) on the Connect Tech website for the latest product manuals, installation guides, diagnostic utilities and device driver software

Windows XP Installation

The following instructions outline how to install the Xtreme/104-Plus to a computer running Windows XP. For other operating system installations, consult the readme.txt and Installation Guides available on the CD shipped with your Xtreme/104-Plus.

1. If you haven't already installed the hardware, turn off the power to your computer and open it to expose the stack (consult your system's documentation for more information on this step).
2. Choose an available position in the PC/104-Plus stack, and set the ID jumper or rotary switch accordingly (see the configuration section later in the manual). Insert the Xtreme/104-Plus adapter and re-assemble the stack.
3. After installing the Xtreme/104-Plus adapter, turn on your system and the Found New Hardware Wizard will appear.



Step 3- Found New Hardware

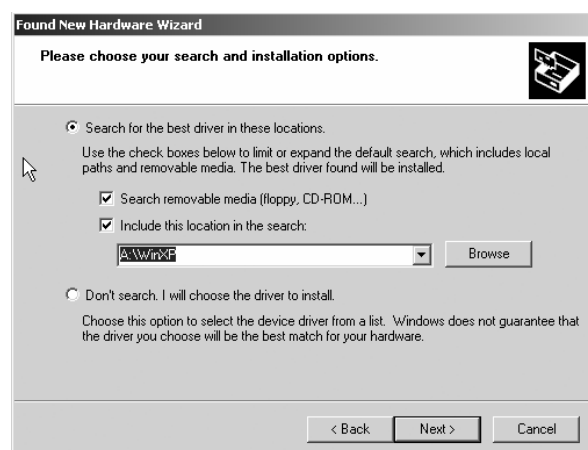

Step 5 – Search for drivers

4. Insert the Xtreme/104-Plus CD into your drive. Choose what you want the wizard to do by selecting Install from a list or specific location (Advanced). Select Next.
5. Choose Select removable media (floppy, CD-ROM) and Include this location in the search and type D:\ Drivers\Win2K-XP, where D is the drive letter of your CD ROM. Now select Finish.

The Found New Hardware Wizard will repeat steps 3 through 5 to complete the installation of the Xtreme/104-Plus serial ports. Please follow the on-screen instructions. Installation is complete when no more dialogue boxes appear.

Verify the presence of Xtreme/104-Plus serial ports in your system by going to Start – Control Panel – System – Hardware – Device Manager – Multi-port serial adapters. You should see CTI x-PORT PCI UART RS232/485/423 listed.

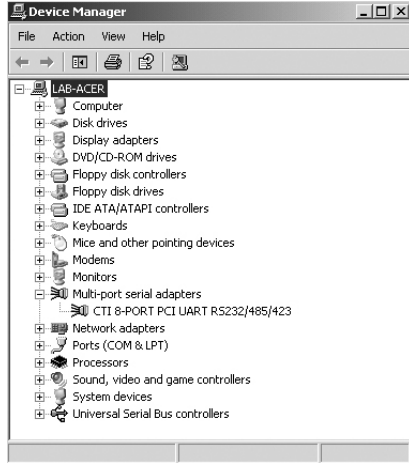

Port Settings

You can now access individual port settings such as baud rate, data bits, parity, stop bits and flow control by choosing the appropriate CTI PCI UART serial port under Ports in the Device Manager. Clicking on Advanced while in Port Settings will access port settings for FIFO buffers, Baud Rate Mapping, and RS-422/485 options (see the [RS-422/485 Electrical Interface](#) section for more details.)

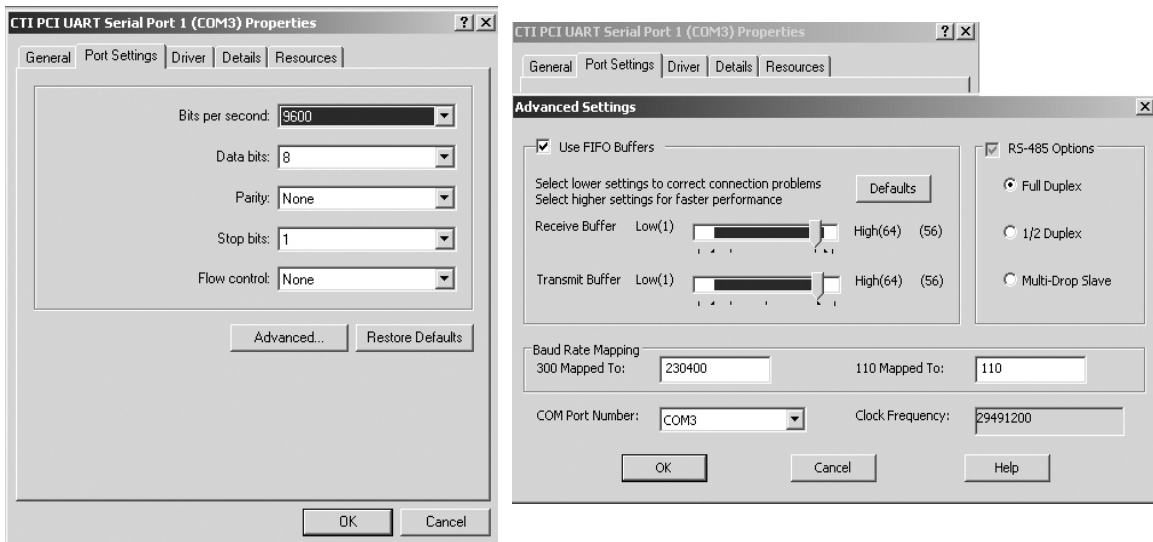

Specifications

Operating Environment

- Storage temperature: -40° C to 125° C
- Operating temperature: -40° C to 85° C (standard version)
- Humidity: 95% non-condensing

Power Requirements

Xtreme/104-Plus RS-423 models

+5 V DC +/-5% @ 100 mA (max.) 2 port models

Xtreme/104-Plus RS-232/422/485 models

+5 V DC +/-5% @ 385 mA (max.) 4 port models

+5 V DC +/-5% @ 575 mA (max.) 8 port models

Xtreme/104-Plus RS-232/422/48/TTL models

+5 V DC +/-5% @ 575 mA (max.) 8 port models

PC Bus Interface

3.3V or 5V PC/104-Plus or PCI-104

Dimensions

PC/104-Plus Standard

Communications

Baud Rates

RS-232/TTL: 50 bps – 921.6 Kbps

RS-422/485: 50 bps – 1.8432 Mbps

RS-423: 50 bps – 115.2 Kbps

UARTs

Dual, quad or octal Exar PCI UARTs provide 64 byte transmit and receive FIFO buffers for each port

Control Signals

RS-423 Models

RS-423: TxD-, TxDRef, RxD+/-, RTS-, RTSRef and CTS+/-

RS-232/422/485 Models

RS-232: TxD, RxD, RTS, CTS, RI, DTR, DSR, DCD and Signal Ground (SG)

RS-422/485: TxD+/-, RxD+/-, RTS+/-, CTS+/- and Signal Return (SR)

RS-232/422/485/TTL Models

RS-232/TTL: TxD, RxD, RTS, CTS, RI, DTR, DSR, DCD, Signal Ground (SG) and +5V

RS-422/485: TxD+/-, RxD+/- and Signal Return (SR)

Certification

The Xtreme/104-Plus product family is to be included into a device ultimately subject to FCC, DOC/IC, and CE certification. The customer is responsible for bringing the completed device into compliance prior to resale. Connect Tech has designed the Xtreme/104-Plus with EMI and EMC considerations such as:

- Ground and power planes
- EMI/EMC reducing PCB layout